

# SNOWSOUND

release 1.0

**Caimi**  
B R E V E T T I

# Caimi

B R E V E T T I

## SNOWSOUND DIVISION

Caimi Brevetti S.p.A. si riserva, a proprio insindacabile giudizio, la facoltà di modificare senza preavviso i materiali costruttivi, le caratteristiche tecniche ed estetiche, nonché le dimensioni degli elementi illustrati nel presente listino le cui immagini e colori sono puramente indicativi.

Caimi Brevetti S.p.A. reserves, by its unappealable judgment, the right to modify without prior notice the building materials, the technical and aesthetic specifications, as well as the dimensions of the products in this price list, where pictures and colours are purely as an indication.

Caimi Brevetti S.p.A. se réserve, à son jugement sans appel, la faculté de modifier sans aucun préavis les matériaux de construction, les caractéristiques techniques et esthétiques ainsi que les dimensions des éléments illustrés dans ce tarif, dont les images et couleurs sont seulement indicatifs.

Caimi Brevetti S.p.A. se reserva, a su indiscutible juicio, el derecho a modificar sin previo aviso los materiales de construcción, las características técnicas y estéticas, así como las medidas de los productos del presente lista de precios, donde las imágenes y los colores son meramente indicativos.

Caimi Brevetti S.p.A. behält sich das Recht vor, ihrer unkontrollierbaren Meinung nach, verwendete Materialien, technische und ästhetische Änderungen sowie die Abmessungen der in diesem Preisliste abgebildeten Produkte ohne vorherige Ankündigung zu ändern. Die gezeigten Fotos und deren Farben dienen ausschliesslich zur ungefähren Information.

# PREMI AWARDS



International CES Innovations  
Design and Engineering  
Awards  
(U.S.A.)



Best of NeoCon  
(U.S.A.)



Product Innovation  
Merit Award  
(U.S.A.)



Trophée de l'Innovation  
Bureaux Expo  
(France)



Ho.Re.Ca.  
Innovazione dell'anno  
(Italy)



Gran Design Etico  
International Award  
Product: Miteco  
(Italy)



Gran Design Etico  
International Award  
Product: Flap  
(Italy)



German Design Award  
Special Mention: Flap  
(Germany)



German Design Award  
Product: Miteco  
(Germany)



ADI Design Index  
Product: Flap  
(Italy)

# COLORI PANNELLI - PANELS' COLOURS COULEURS PANNEAUX - COLORES PANELES - PANELEE FARBEN

**6071**



Blu - Blue - Bleu - Azul - Blau

**8033**



Nero - Black - Noir - Negro - Schwarz

**4027**



Rosso - Red - Rouge - Rojo - Rot

**8004**

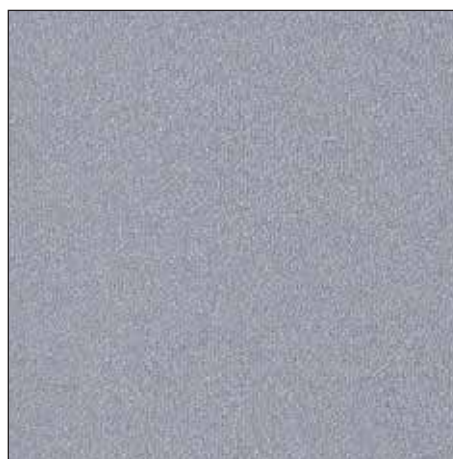

Grigio argento - Silver grey - Gris argenté -  
Gris plata - Silbergrau

**7013**



Verde Mela - Apple green - Vert Pomme  
Verde Manzana - Grüner Apfel

**0001**



Bianco - White - Blanc - Blanco - Weiss

**8007**



Grigio scuro - Dark grey - Gris foncé -  
Gris oscuro - Dunkelgrau

**4030**

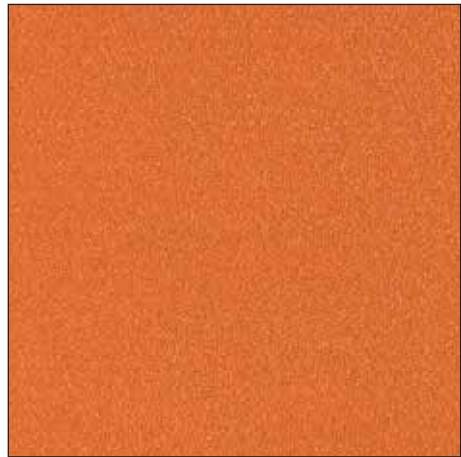

Arancione Carota - Carrot orange -  
Orange Carotte - Anaranjado Zanahoria -  
Orange Karotte

**2005**

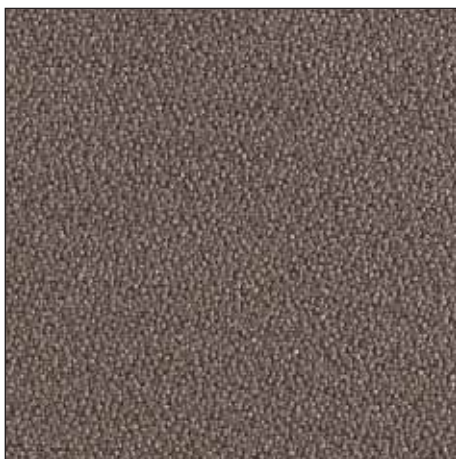

Tortora - Dove-grey - Taupe  
Tórtola - Taubengrau

**3008**



Giallo Sole - Sun yellow - Jaune Soleil  
Amarillo Sol - Gelbe Sonne

**1008**



Beige - Beige - Beige - Beige - Beige

**7004**



Verde chiaro - Light green - Vert clair  
Verde claro - Hellgrün

# INDICE / INDEX



Mitesco page 8



Mitesco Easy / Magnetic page 14



Mitesco Wall / Ceiling page 16



Mitesco Cables page 18



Mitesco Totem page 22



Mitesco Divider page 24

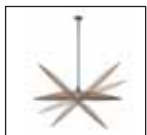

Mitesco Ceiling page 38



Mitesco Frame page 46



Mitesco Net page 50



Mitesco Desk page 56



Snowdesk page 64



Flap / Maxiflap page 68



Flap Led

page 72



Flap Totem

page 74



Flap Ceiling

page 76



V-Flap

page 80



President

page 82



Pli

page 88



Baffle

page 90



Tra

page 94



In

page 98



Corista

page 100



Cocker

page 101



Snowall

page 102



# MITESCO 159/119/75x44 cm design Michele De Lucchi Snowsound® technology by Caimi Brevetti

## Descrizione Description

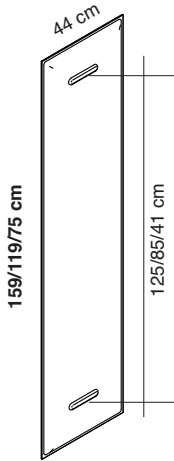

Pannello con imbottitura interna in poliester a **densità variabile** Snowsound® Technology. Rivestimento esterno in tessuto di poliester Trevira CS®.

Completo di attacchi in tecnopolimero e acciaio e coperture frontali in tecnopolimero grigio o bianco.

Il pannello può essere fissato direttamente a parete tramite viti (non incluse).

Il pannello può essere fissato direttamente anche a soffitto tramite viti (non incluse), utilizzando l'apposto profilo livellatore (non incluso) cod. 7M160-GA, per pannelli L. 159 cm, 7M120-GA, per pannelli L. 119 cm o 7M80-GA, per pannelli L. 75 cm.

Peso del singolo pannello 2,7 / 2,3 / 1,5 Kg.

Panel with polyester internal padding with Snowsound® Technology **variable density**. Polyester covering in Trevira CS® fabric. Supplied with connections in high-tech polymer and steel and grey or white high-tech polymer front covers.

The panel can be directly fixed to the wall through screws (not included).

The panel can be also fixed directly to the ceiling with screws (not included), by using the dedicated leveler profile (not included) cod. 7M160-GA, for panels L. 159 cm, 7M120-GA pr pannelli L. 119 cm or 7M80-GA, for panels L. 75 cm.

Weight of single panel: 2,7 / 2,3 / 1,5 kg

Panneau avec rembourrage interne en polyester à **densité variable** Snowsound® Technology. Revêtement externe en tissu de polyester Trevira CS®.

Avec jonctions en technopolymère et acier et couvertures frontales en technopolymère gris ou blanc.

On peut fixer le panneau directement au mur par des vis (pas incluses).

On peut aussi fixer le panneau directement au plafond par des vis (pas incluses) en utilisant le spécial profil niveleur (pas inclus) réf. 7M160-GA, pour panneaux L. 159 cm, 7M120-GA, pour panneaux L. 119 cm ou 7M80-GA, pour panneaux L. 75 cm.

Poids d'un panneau: 2,7 / 2,3 / 1,5 kg

Panel con acolchado interior de poliéster de **densidad variable** Snowsound® Technology. Revestimiento exterior de tejido de poliéster Trevira CS®.

Incluye enganches de polímero y acero y coberturas frontales de polímero gris o blanco.

El panel puede ser fijado directamente a la pared por medio de tornillos (no incluydos).

El panel puede ser tambien fijado directamente al techo por medio de tornillos (no incluydos) utilizando el correspondiente perfil nivelador (no incluydo) cod. 7M160-GA, por paneles L. 159 cm, 7M120-GA, por paneles L. 119 cm o 7M80-GA, por paneles L. 75 cm.

Peso para singulo panel 2,7 / 2,3 / 1,5 Kg.

Panel mit Polyester-Füllmaterial von **unterschiedlicher Dichte** Snowsound® Technology. Polyester-Bezug aus Trevira CS®-Material.

Inklusive Beschlägen aus Technopolymer und Stahl sowie grauen oder weissen Befestigungsabdeckungen aus Technopolymer.

Das Paneel kann mit Schrauben (nicht inkludiert) direkt an der Wand montiert werden.

Das Paneel kann auch unter Verwendung des Justierungsprofils Art. Nr. 7M160-GA, für Paneel L. 159 cm, 7M120-GA, für Paneel L. 119 cm oder 7M80-GA, für Paneel L. 75 cm (nicht inkludiert) mit Schrauben (nicht inkludiert) direkt an der Decke befestigt werden.

Gewicht eines Paneels: 2,7 / 2,3 / 1,5 kg.



Montaggio semplice a parete pannello Mitesco  
Basic wall mounting for Mitesco panel

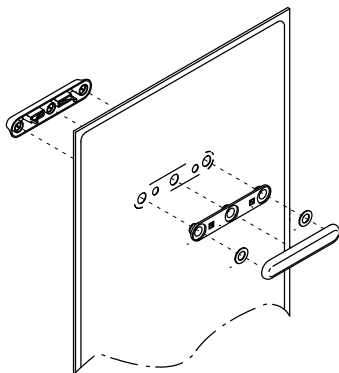

Dettaglio dell'attacco con copertura frontale forniti di serie in colore grigio o bianco. Le coperture frontali sono disponibili anche colorate cod. 7M102-XXXX (XXXX = Variante colore).

Detail of the connection and front cover in standard grey or white. The front covers are also available in other colours with code 7M102-XXXX (XXXX = colour option).

Détail de la jonction avec couverture frontale, fournie standard en couleur gris ou blanc. Les couvertures frontales sont disponibles aussi dans d'autres couleurs avec réf. 7M102-XXXX (XXXX = option couleur).

Detalle ataque con cobertura frontal incluyda en color gris o blanco. Las coberturas frontales son disponibles también en color cod. 7M102-XXXX (XXXX = Variante color).

Detaildarstellung der Befestigungsbeschläge mit standardmäßiger Abdeckung in grau oder weiss. Die Abdeckungen sind auch in anderen Farben erhältlich, Art. 7M102-XXXX (XXXX = Farbvariante).



Dettaglio attacco e copertura frontale colore grigio.

Detail of the connection and front cover. Grey colour.

Détail jonction et couverture frontale, couleur gris.



Detalle ataque y cobertura frontal color gris.

Detaildarstellung der Befestigungsbeschläge und grauer Abdeckung



Dettaglio attacco e copertura frontale colore bianco.

Detail of the connection and front cover. White colour.

Détail jonction et couverture frontale, couleur blanc.













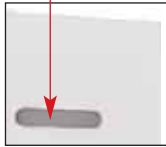









Detalle ataque y cobertura frontal color blanco.

Detaildarstellung der Befestigungsbeschläge und weisser Abdeckung







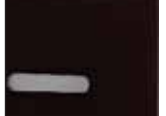
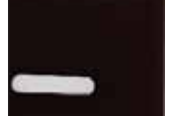





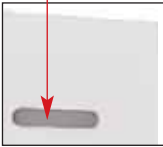
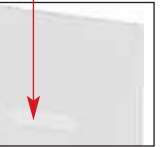











# MITESCO 159x44 cm

design Michele De Lucchi  
Snowsound® technology by Caimi Brevetti

Copertura grigia Grey cover Couverture gris Cobertura gris Graue Abdeckung	Colore Colour	Codice Code	Prezzo Cad. Price each	Copertura bianca White cover Couverture blanche Cobertura blanca Weisse Abdeckung	Colore Colour	Codice Code	Prezzo Cad. Price each
	Bianco White Blanc <b>0001</b>	<b>7M1016-0001</b>			Bianco White Blanc <b>0001</b>	<b>7M1016BO-0001</b>	
	Grigio argento Silver grey Gris argenté <b>8004</b>	<b>7M1016-8004</b>			Grigio argento Silver grey Gris argenté <b>8004</b>	<b>7M1016BO-8004</b>	
	Grigio scuro Dark grey Gris foncté <b>8007</b>	<b>7M1016-8007</b>			Grigio scuro Dark grey Gris foncté <b>8007</b>	<b>7M1016BO-8007</b>	
	Beige Beige Beige <b>1008</b>	<b>7M1016-1008</b>			Beige Beige Beige <b>1008</b>	<b>7M1016BO-1008</b>	
	Tortora Dove-grey Taupe <b>2005</b>	<b>7M1016-2005</b>			Tortora Dove-grey Taupe <b>2005</b>	<b>7M1016BO-2005</b>	
	Giallo Yellow Jaune <b>3008</b>	<b>7M1016-3008</b>			Giallo Yellow Jaune <b>3008</b>	<b>7M1016BO-3008</b>	
	Arancione Orange Orange <b>4030</b>	<b>7M1016-4030</b>			Arancione Orange Orange <b>4030</b>	<b>7M1016BO-4030</b>	
	Rosso Red Rouge <b>4027</b>	<b>7M1016-4027</b>			Rosso Red Rouge <b>4027</b>	<b>7M1016BO-4027</b>	
	Verde chiaro Light green Vert clair <b>7004</b>	<b>7M1016-7004</b>			Verde chiaro Light green Vert clair <b>7004</b>	<b>7M1016BO-7004</b>	
	Verde Green Vert <b>7013</b>	<b>7M1016-7013</b>			Verde Green Vert <b>7013</b>	<b>7M1016BO-7013</b>	
	Blu Blue Bleu <b>6071</b>	<b>7M1016-6071</b>			Blu Blue Bleu <b>6071</b>	<b>7M1016BO-6071</b>	
	Nero Black Noir <b>8033</b>	<b>7M1016-8033</b>			Nero Black Noir <b>8033</b>	<b>7M1016BO-8033</b>	



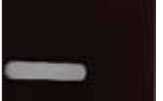







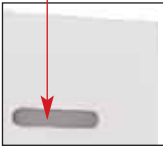
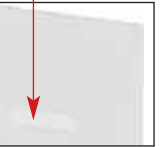











# MITESCO 119x44 cm

design Michele De Lucchi  
Snowsound® technology by Caimi Brevetti

Copertura grigia Grey cover Couverture gris Cobertura gris Graue Abdeckung	Colore Colour	Codice Code	Prezzo Cad. Price each	Copertura bianca White cover Couverture blanche Cobertura blanca Weisse Abdeckung	Colore Colour	Codice Code	Prezzo Cad. Price each
	Bianco White Blanc <b>0001</b>	<b>7M1012-0001</b>			Bianco White Blanc <b>0001</b>	<b>7M1012BO-0001</b>	
	Grigio argento Silver grey Gris argenté <b>8004</b>	<b>7M1012-8004</b>			Grigio argento Silver grey Gris argenté <b>8004</b>	<b>7M1012BO-8004</b>	
	Grigio scuro Dark grey Gris foncé <b>8007</b>	<b>7M1012-8007</b>			Grigio scuro Dark grey Gris foncé <b>8007</b>	<b>7M1012BO-8007</b>	
	Beige Beige Beige <b>1008</b>	<b>7M1012-1008</b>			Beige Beige Beige <b>1008</b>	<b>7M1012BO-1008</b>	
	Tortora Dove-grey Taupe <b>2005</b>	<b>7M1012-2005</b>			Tortora Dove-grey Taupe <b>2005</b>	<b>7M1012BO-2005</b>	
	Giallo Yellow Jaune <b>3008</b>	<b>7M1012-3008</b>			Giallo Yellow Jaune <b>3008</b>	<b>7M1012BO-3008</b>	
	Arancione Orange Orange <b>4030</b>	<b>7M1012-4030</b>			Arancione Orange Orange <b>4030</b>	<b>7M1012BO-4030</b>	
	Rosso Red Rouge <b>4027</b>	<b>7M1012-4027</b>			Rosso Red Rouge <b>4027</b>	<b>7M1012BO-4027</b>	
	Verde chiaro Light green Vert clair <b>7004</b>	<b>7M1012-7004</b>			Verde chiaro Light green Vert clair <b>7004</b>	<b>7M1012BO-7004</b>	
	Verde Green Vert <b>7013</b>	<b>7M1012-7013</b>			Verde Green Vert <b>7013</b>	<b>7M1012BO-7013</b>	
	Blu Blue Bleu <b>6071</b>	<b>7M1012-6071</b>			Blu Blue Bleu <b>6071</b>	<b>7M1012BO-6071</b>	
	Nero Black Noir <b>8033</b>	<b>7M1012-8033</b>			Nero Black Noir <b>8033</b>	<b>7M1012BO-8033</b>	

# MITESCO 75x44 cm

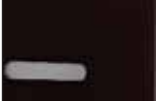
design Michele De Lucchi  
Snowsound® technology by Caimi Brevetti

Copertura grigia Grey cover Couverture gris Cobertura gris Graue Abdeckung	Colore Colour	Codice Code	Prezzo Cad. Price each	Copertura bianca White cover Couverture blanche Cobertura blanca Weisse Abdeckung	Colore Colour	Codice Code	Prezzo Cad. Price each
	Bianco White Blanc <b>0001</b>	<b>7M1008-0001</b>			Bianco White Blanc <b>0001</b>	<b>7M1008BO-0001</b>	
	Grigio argento Silver grey Gris argenté <b>8004</b>	<b>7M1008-8004</b>			Grigio argento Silver grey Gris argenté <b>8004</b>	<b>7M1008BO-8004</b>	
	Grigio scuro Dark grey Gris foncté <b>8007</b>	<b>7M1008-8007</b>			Grigio scuro Dark grey Gris foncté <b>8007</b>	<b>7M1008BO-8007</b>	
	Beige Beige Beige <b>1008</b>	<b>7M1008-1008</b>			Beige Beige Beige <b>1008</b>	<b>7M1008BO-1008</b>	
	Tortora Dove-grey Taupe <b>2005</b>	<b>7M1008-2005</b>			Tortora Dove-grey Taupe <b>2005</b>	<b>7M1008BO-2005</b>	
	Giallo Yellow Jaune <b>3008</b>	<b>7M1008-3008</b>			Giallo Yellow Jaune <b>3008</b>	<b>7M1008BO-3008</b>	
	Arancione Orange Orange <b>4030</b>	<b>7M1008-4030</b>			Arancione Orange Orange <b>4030</b>	<b>7M1008BO-4030</b>	
	Rosso Red Rouge <b>4027</b>	<b>7M1008-4027</b>			Rosso Red Rouge <b>4027</b>	<b>7M1016BO-4027</b>	
	Verde chiaro Light green Vert clair <b>7004</b>	<b>7M1008-7004</b>			Verde chiaro Light green Vert clair <b>7004</b>	<b>7M1008BO-7004</b>	
	Verde Green Vert <b>7013</b>	<b>7M1008-7013</b>			Verde Green Vert <b>7013</b>	<b>7M1008BO-7013</b>	
	Blu Blue Bleu <b>6071</b>	<b>7M1008-6071</b>			Blu Blue Bleu <b>6071</b>	<b>7M1008BO-6071</b>	
	Nero Black Noir <b>8033</b>	<b>7M1008-8033</b>			Nero Black Noir <b>8033</b>	<b>7M1008BO-8033</b>	

Codice Code	Colore Colour	Prezzo Price	Descrizione Description
7M102-0001	Bianco White Blanc Weiss Blanco	1 coppia / 1 pair 1 paire / 1 pare 1 Paar	Coppia di coperture frontali in tecnopolimero degli attacchi per 1 pannello Mitesco. <b>OPZIONALE</b> (Il pannello Mitesco è fornito di serie con le coperture frontali di colore grigio o bianco)
7M102-8004	Grigio argento Silver grey Gris argenté Gris plata Silbergrau	1 coppia / 1 pair 1 paire / 1 pare 1 Paar	Pair of high-tech polymer front covers for connections for 1 panel Mitesco. <b>OPTIONAL</b> (Mitesco panels are supplied as standard with grey or white front covers)
7M102-8007	Grigio scuro Dark grey Gris foncé Gris oscuro Dunkelgrau	1 coppia / 1 pair 1 paire / 1 pare 1 Paar	Paire de couvertures frontales en technopolymère pour jonctions pour 1 panneau Mitesco. <b>OPTIONNEL</b> (Le panneau Mitesco est fourni en standard avec les couvertures frontales en couleur gris ou blanc)
7M102-1008	Beige Beige Beige Beige Beige	1 coppia / 1 pair 1 paire / 1 pare 1 Paar	Par de coberturas frontales de tecnopolimero para enganches de 1 panel Mitesco. <b>OPCIONAL</b> (el panel Mitesco ya incluye las coberturas frontales en color gris o blanco)
7M102-2005	Tortora Dove-grey Taupe Tórtola Taubengrau	1 coppia / 1 pair 1 paire / 1 pare 1 Paar	Paar Abdeckungen aus Technopolymer für Befestigung für 1 Paneel Mitesco. <b>OPTIONAL erhältlich</b> (Mitesco-Paneele werden standardmäßig mit grauen oder weissen Befestigungsabdeckungen geliefert).
7M102-3008	Giallo Yellow Jaune Amarillo Gelbe	1 coppia / 1 pair 1 paire / 1 pare 1 Paar	<b>NOTA</b> Non utilizzare con staffe scrivania cod. 7M511-XX / 7M515-XX / 7M5100-XX / 7M519-XX / 7M518-XX / 7M517-XX (XX = Variante colore). Not to be used with desk brackets code 7M511-XX / 7M515-XX / 7M5100-XX / 7M519-XX / 7M518-XX / 7M517-XX (XX = colour option).
7M102-4030	Arancione Orange Orange Anaranjado Orange	1 coppia / 1 pair 1 paire / 1 pare 1 Paar	Ne pas utiliser avec étriers pour bureau réf 7M511-XX / 7M515-XX / 7M5100-XX / 7M519-XX / 7M518-XX / 7M517-XX (XX = option couleur). No utilizar con abrazaderas para mesa cod. 7M511-XX / 7M515-XX / 7M5100-XX / 7M519-XX / 7M518-XX / 7M517-XX (XX = Variante color).
7M102-4027	Rosso Red Rouge Rojo Rot	1 coppia / 1 pair 1 paire / 1 pare 1 Paar	Nicht zur Verwendung mit Halterungen für Tisch Art. 7M511-XX / 7M515-XX / 7M5100-XX / 7M519-XX / 7M518-XX / 7M517-XX (XX = Farbvariante).
7M102-7004	Verde chiaro Light green Vert clair Verde claro Hellgrün	1 coppia / 1 pair 1 paire / 1 pare 1 Paar	
7M102-7013	Verde Green Vert Verde Grüner	1 coppia / 1 pair 1 paire / 1 pare 1 Paar	
7M102-6071	Blu Blue Bleu Azul Blau	1 coppia / 1 pair 1 paire / 1 pare 1 Paar	
7M102-8033	Nero Black Noir Negro Schwarz	1 coppia / 1 pair 1 paire / 1 pare 1 Paar	

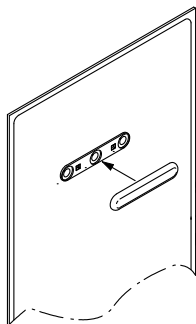
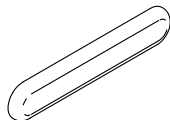
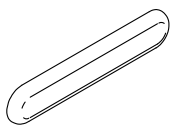

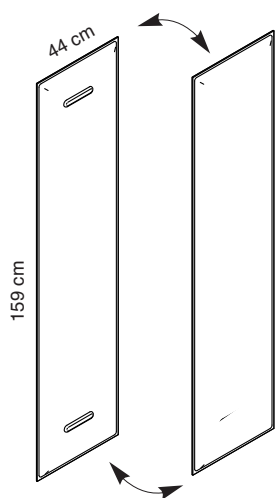

Codice Code	Prezzo Price	Descrizione Description
<b>7MCT160-IN9106</b>		Coperture in tessuto di poliestere Trevira CS® per pannelli Mitesco 7M1016-XXXX, 7M1016BO-XXXX (XXXX = Variante colore). Per ottenere lo stesso risultato in termini di performance acustiche, l'utilizzo delle coperture richiede un aumento del numero di pannelli di circa il 20%. Non indicate per pannelli applicati a soffitto.
<b>7MCT160-IN9222</b>		Covers for Mitesco panels made of polyester fabric Trevira CS® codes 7M1016-XXXX, 7M1016BO-XXXX (XXXX = colour option) To achieve the same result in terms of acoustic performance when using the fabric covers you need to increase the number of panels by approximately 20% Not suitable for ceiling mounted panels.
<b>7MCT160-IN9404</b>		Revêtements en tissu polyester Trevira CS pour panneaux Mitesco 7M1016-XXXX, 7M1016BO-XXXX (XXXX = option couleur) Pour obtenir le même résultat en termes de performance acoustique, l'utilisation des revêtements comporte une augmentation du nombre de panneaux d'environ le 20%. Pas adaptées pour panneaux avec fixation au plafond.
<b>7MCT160-IN9601</b>		Coberturas en tejido de poliester Trevira CS para paneles Mitesco 7M1016-XXXX, 7M1016BO-XXXX (XXXX variante color). Para obtener el mismo resultado en tema de performance acusticas la utilizacion de las coberturas requieren un aumento en el numero de paneles aproximadamente del 20% No indicadas para paneles montados en el techo
<b>7MCT160-IN9809</b>		Verkleidungen für Mitesco Paneele aus Polyesterstoff Trevira CS® 7M1016-XXXX, 7M1016BO-XXXX (XXXX = Farbvariante). Um den gleichen Effekt hinsichtlich der Akustikoptimierung zu erreichen, sollte bei Verwendung der Stoffbezüge die Anzahl der Paneele um ca. 20 % erhöht werden. Nicht geeignet für Paneele, die an der Decke befestigt werden.
<b>7MCT160-AR8006</b>		
<b>7MCT160-AR8070</b>		
<b>7MCT160-CL9309</b>		
<b>7MCT160-CL9702</b>		



# MITESCO EASY

design Michele De Lucchi  
Snowsound® technology by Caimi Brevetti

Codice Code	Colore Colour	Prezzo Price	Descrizione Description
----------------	------------------	-----------------	----------------------------

7M210-GR

Grigio  
Silver  
Gris  
Gris  
Grau

Aggancio semplice in tecnopolimero per fissaggio a parete tramite chiodo/vite (non inclusi) di un pannello Mitesco.

Easy connection in high-tech polymer for wall fixing by nail/screw (not included) of 1 Mitesco panel.

Accrochage simple en technopolymère pour fixation au mur par un clou/vis (pas inclus) d'un panneau Mitesco.

Enganche simple de polímero para fijación a pared por medio de clavo / tornillo (no incluido) de un panel Mitesco.

Einfache Befestigung aus Technopolymer für die Wandmontage mittels Nagel/Schraube (nicht inkludiert) eines Mitesco-Paneels.



7M2320-GR page 15

## MAGNETIC





# MITESCO MAGNETIC

design Michele De Lucchi  
Snowsound® technology by Caimi Brevetti

	Codice Code	Colore Colour	Prezzo Price	Descrizione Description
<p>Fe = Ferro Iron Fer Hierro Eisen</p>	7M232			<p>Kit 4 magneti per il fissaggio diretto ad una superficie verticale in ferro di un pannello Mitesco.</p> <p>Set of 4 magnets for direct fixing to a vertical iron surface, of 1 Mitesco panel.</p> <p>Jeu de 4 aimants pour la fixation directe à une surface verticale en fer d'un panneau Mitesco.</p> <p>Kit de 4 imanes para la fijación directa a una superficie vertical de hierro de un panel Mitesco.</p> <p>Set von 4 Magneten zur direkten Befestigung auf einer vertikal Eisenoberfläche, für 1 Mitesco-Paneel.</p>
<p>ø 3 cm</p> <p>ø 5,5 cm</p> <p>(1)</p> <p>(2)</p>	7M2320-GR			<p>Kit per il fissaggio ad una superficie verticale in vetro o in muratura di un pannello Mitesco.</p> <p>Il kit è composto da: 4 magneti (A) / 4 dischi in acciaio e tecnopolimero grigio (B) / 4 dischi con biadesivo (C).</p> <p>(1) Per le superfici in vetro applicare gli appositi dischetti con biadesivo (C).</p> <p>(2) Per le superfici in muratura applicare direttamente i dischetti (B) tramite viti (non incluse)</p> <p>Set for fixing to a glass or masonry vertical surface, of 1 Mitesco panel.</p> <p>Set composed of: 4 magnets (A) / 4 steel and high-tech polymer plates (B) / 4 plates with double-sided adhesive tape (C).</p> <p>(1) For glass surfaces use the suitable plates with double-sided adhesive tape (C)</p> <p>(2) For masonry surfaces fix directly the plates (B) with screws (not included)</p> <p>Jeu pour fixation à une surface verticale en verre ou maçonnerie d'un panneau Mitesco.</p> <p>Le jeu se compose de: 4 aimants (A) / 4 disques en acier et technopolymère (B) / 4 disques avec bande biadhésive (C).</p> <p>(1) Pour les surfaces en verre appliquer les disques par bande biadhésive (C)</p> <p>(2) Pour les surfaces en maçonnerie appliquer directement les disques (B) par des vis (pas incluses)</p> <p>Kit para fijación a una superficie vertical de vidrio o de mampostería de un panel Mitesco.</p> <p>Kit compuesto por: 4 imanes (A) / 4 discos de acero y polímero (B) / 4 discos con bi-adesivo (C).</p> <p>(1) Para las superficies de vidrio aplicar los discos con su propio bi-adesivo (C)</p> <p>(2) Para las superficies de mampostería aplicar directamente los discos (B) con tornillos (no incluidos)</p> <p>Set zur Montage auf vertikal Glasoberflächen und Mauerwerk, für 1 Mitesco-Paneel.</p> <p>Set von: 4 Magneten (A) / 4 Scheiben aus Stahl und Technopolymer (B) / 4 doppelseitig klebende Scheiben (C).</p> <p>(1) Für Glasoberflächen verwenden Sie die entsprechenden doppelseitig klebenden Scheiben (C)</p> <p>(2) Für Mauerwerk befestigen Sie die Scheiben direkt (B) mit Schrauben (nicht inkludiert)</p>

# MITESCO CEILING

design Michele De Lucchi  
Snowsound® technology by Caimi Brevetti

	Codice Code	Colore Colour	Prezzo Price	Descrizione Description
	<p><b>7M160-GA</b></p>	<p>Grigio argento Silver grey Gris argenté Gris plata Silbergrau</p>	<p><b>Per pannelli For panels L. 159 cm</b></p>	<p>Profilo livellatore in acciaio verniciato con polveri epossidiche e tecnopolimero per 1 pannello Mitesco: 7M1016-XXXX, 7M1016BO-XXXX (XXXX = Variante colore). Utilizzare sempre in caso di fissaggio del pannello al soffitto in posizione orizzontale (parallela al piano).</p> <p>Leveler profile in powder coated steel and high-tech polymer for 1 Mitesco panel code: 7M1016-XXXX, 7M1016BO-XXXX (XXXX = colour option). To be always used in case of fixation of the panel to the ceiling in horizontal position (parallel to the floor).</p> <p>Profil niveleur en acier peint en époxy et technopolymère pour un panneau Mitesco: 7M1016-XXXX, 7M1016BO-XXXX (XXXX = option couleur). Toujours à prévoir en cas d'accrochage du panneau au plafond en position horizontale (parallèle à la surface).</p> <p>Perfil nivelador de acero recubierto epoxi y polímero para 1 panel Mitesco cod. 7M1016-XXXX, 7M1016BO-XXXX (XXXX = opción color). Utilizar siempre en caso de enganche del panel al techo en posición horizontal (paralelo al plano).</p> <p>Justierungsprofil aus pulverbeschichtetem Stahl und Technopolymer für 1 Mitesco-Paneel Art.-Nr. 7M1016-XXXX, 7M1016BO-XXXX (XXXX = Farbvariante). Immer verwenden wenn das Paneel in horizontaler Position an der Decke befestigt wird. (Parallel zur Ebene).</p>
	<p><b>7M120-GA</b></p>	<p>Grigio argento Silver grey Gris argenté Gris plata Silbergrau</p>	<p><b>Per pannelli For panels L. 119 cm</b></p>	<p>Profilo livellatore in acciaio verniciato con polveri epossidiche e tecnopolimero per 1 pannello Mitesco: 7M1012-XXXX, 7M1012BO-XXXX (XXXX = Variante colore). Utilizzare sempre in caso di fissaggio del pannello al soffitto in posizione orizzontale (parallela al piano).</p> <p>Leveler profile in powder coated steel and high-tech polymer for 1 Mitesco panel code: 7M1012-XXXX, 7M1012BO-XXXX (XXXX = colour option). To be always used in case of fixation of the panel to the ceiling in horizontal position (parallel to the floor).</p> <p>Profil niveleur en acier peint en époxy et technopolymère pour un panneau Mitesco: 7M1012-XXXX, 7M1012BO-XXXX (XXXX = option couleur). Toujours à prévoir en cas d'accrochage du panneau au plafond en position horizontale (parallèle à la surface).</p> <p>Perfil nivelador de acero recubierto epoxi y polímero para 1 panel Mitesco cod. 7M1012-XXXX, 7M1012BO-XXXX (XXXX = opción color). Utilizar siempre en caso de enganche del panel al techo en posición horizontal (paralelo al plano).</p> <p>Justierungsprofil aus pulverbeschichtetem Stahl und Technopolymer für 1 Mitesco-Paneel Art.-Nr. 7M1012-XXXX, 7M1012BO-XXXX (XXXX = Farbvariante). Immer verwenden wenn das Paneel in horizontaler Position an der Decke befestigt wird. (Parallel zur Ebene).</p>
	<p><b>7M80-GA</b></p>	<p>Grigio argento Silver grey Gris argenté Gris plata Silbergrau</p>	<p><b>Per pannelli For panels L. 75 cm</b></p>	<p>Profilo livellatore in acciaio verniciato con polveri epossidiche e tecnopolimero per 1 pannello Mitesco: 7M1008-XXXX, 7M1008BO-XXXX (XXXX = Variante colore). Utilizzare sempre in caso di fissaggio del pannello al soffitto in posizione orizzontale (parallela al piano).</p> <p>Leveler profile in powder coated steel and high-tech polymer for 1 Mitesco panel code: 7M1008-XXXX, 7M1008BO-XXXX (XXXX = colour option). To be always used in case of fixation of the panel to the ceiling in horizontal position (parallel to the floor).</p> <p>Profil niveleur en acier peint en époxy et technopolymère pour un panneau Mitesco: 7M1008-XXXX, 7M1008BO-XXXX (XXXX = option couleur). Toujours à prévoir en cas d'accrochage du panneau au plafond en position horizontale (parallèle à la surface).</p> <p>Perfil nivelador de acero recubierto epoxi y polímero para 1 panel Mitesco cod. 7M1008-XXXX, 7M1008BO-XXXX (XXXX = opción color). Utilizar siempre en caso de enganche del panel al techo en posición horizontal (paralelo al plano).</p> <p>Justierungsprofil aus pulverbeschichtetem Stahl und Technopolymer für 1 Mitesco-Paneel Art.-Nr. 7M1008-XXXX, 7M1008BO-XXXX (XXXX = Farbvariante). Immer verwenden wenn das Paneel in horizontaler Position an der Decke befestigt wird. (Parallel zur Ebene).</p>

# MITESCO WALL/CEILING

design Michele De Lucchi  
Snowsound® technology by Caimi Brevetti

	Codice Code	Colore Colour	Prezzo Price	Descrizione Description
	<b>7M2476-GA</b>	Grigio argento Silver grey Gris argenté Gris plata Silbergrau	<b>Per pannelli For panels L. 159 cm</b>	Coppia attacchi distanziali in acciaio verniciato con polveri epossidiche e tecnopolimero per parete/soffitto, completi di profilo livellatore per pannello Mitesco.  Pair of spacer connections in powder coated steel and high-tech polymer for wall/ceiling, supplied with leveler profile for Mitesco panel.
	<b>7M2472-GA</b>	Grigio argento Silver grey Gris argenté Gris plata Silbergrau	<b>Per pannelli For panels L. 119 cm</b>	Paire d'accrochages espaceurs en acier peint en époxy et technopolymère pour mur/plafond, avec un profil niveleur pour panneau Mitesco.
	<b>7M2478-GA</b>	Grigio argento Silver grey Gris argenté Gris plata Silbergrau	<b>Per pannelli For panels L. 75 cm</b>	Par de enganches espaciadores de acero recubierto epoxi y polímero para pared/techo, incluye perfil nivelador para panel Mitesco.  Paar Distanzhalterbefestigungen aus pulverbeschichtetem Stahl und Technopolymer zur Wand- oder Deckenmontage, inkl. Justierungsprofil für Mitesco-Paneel.
<p>Esempio di montaggio del pannello a parete / Example of mounting for a wall fixed panel</p>	<p>Esempio di montaggio del pannello a soffitto / Example of mounting for a ceiling fixed panel</p>			
	<b>7M2426-GA</b>	Grigio argento Silver grey Gris argenté Gris plata Silbergrau	<b>Per pannelli For panels L. 159 cm</b>	Coppia attacchi distanziali in acciaio verniciato con polveri epossidiche e tecnopolimero per parete/soffitto, completi di profilo livellatore per pannello Mitesco.  Pair of spacer connections in powder coated steel and high-tech polymer for wall/ceiling, supplied with leveler profile for Mitesco panel.
	<b>7M2422-GA</b>	Grigio argento Silver grey Gris argenté Gris plata Silbergrau	<b>Per pannelli For panels L. 119 cm</b>	Paire d'accrochages espaceurs en acier peint en époxy et technopolymère pour mur/plafond, avec un profil niveleur pour panneau Mitesco.
	<b>7M2428-GA</b>	Grigio argento Silver grey Gris argenté Gris plata Silbergrau	<b>Per pannelli For panels L. 75 cm</b>	Par de enganches espaciadores de acero recubierto epoxi y polímero para pared/techo, incluye perfil nivelador para panel Mitesco.  Paar Distanzhalterbefestigungen aus pulverbeschichtetem Stahl und Technopolymer zur Wand- oder Deckenmontage, inkl. Justierungsprofil für Mitesco-Paneel.
<p>Esempio di montaggio del pannello a parete / Example of mounting for a wall fixed panel</p>	<p>Esempio di montaggio del pannello a soffitto / Example of mounting for a ceiling fixed panel</p>			

# MITESCO ON CABLES

design Michele De Lucchi  
Snowsound® technology by Caimi Brevetti

Codice Code	Colore Colour	Prezzo Price	Descrizione Description
7M214			<p data-bbox="975 226 1382 275">Kit 4 morsetti in metallo per cavi cod. 7M5170. Applicabili direttamente a un pannello Mitesco.</p> <p data-bbox="975 304 1441 353">Set of 4 steel clamps to use with cables code 7M5170 They can be applied directly to the Mitesco panel.</p> <p data-bbox="975 383 1469 432">Jeu de 4 étaux en métal pour cables réf. 7M5170. On peut les appliquer directement à un panneau Mitesco.</p> <p data-bbox="975 461 1457 510">Kit de 4 sujetadores de metal para cables cod. 7M5170. Aplicables directamente a un panel Mitesco.</p> <p data-bbox="975 539 1430 620">Set von 4 Klemmen zur Verwendung mit Stahlseilen Art. 7M5170. Befestigung der Klemmen direkt am Mitesco-Paneel.</p>
7M5170			<p data-bbox="975 920 1393 943">1 coppia cavi d'acciaio (4+4 m) + 1 coppia tiranti</p> <p data-bbox="831 954 967 1016"><b>1 coppia / 1 pair</b> 1 paire / 1 par 1 Paar</p> <p data-bbox="975 972 1401 994">Pair of steel cables (4+4 m) + pair of tension rods</p> <p data-bbox="975 1021 1409 1043">Paire de cables en acier (4+4 m) + paire de tirants</p> <p data-bbox="975 1070 1382 1093">Par de cables de acero (4+4 m) + par de pesos</p> <p data-bbox="975 1122 1493 1144">1 Paar Stahlseile (4+4 m) + 1 Paar Befestigungsendstücken</p>

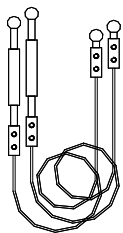
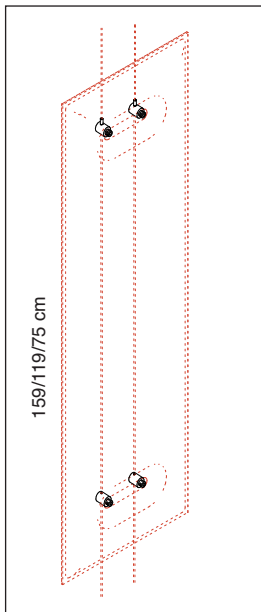
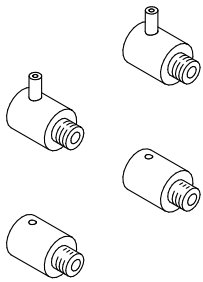

# MITESCO ON CABLES

design Michele De Lucchi  
Snowsound® technology by Caimi Brevetti

	Codice Code	Colore Colour	Prezzo Price	Descrizione Description
	<b>7M5158-GA</b>	Grigio argento Silver grey Gris argenté Gris plata Silbergrau	<b>2 coppie / 2 pairs</b> <b>2 paires / 2 pares</b> <b>2 Paar</b>	<p>2 coppie supporti in acciaio verniciato con polveri epossidiche per fissaggio a parete per cod. 7M5170. (Viti non incluse)</p> <p>2 pairs of powder-coated supports for wall fixing for code 7M5170. (Screws not included)</p> <p>2 paires de supports en acier peint pour fixation murale pour réf. 7M5170. (Vis pas incluses)</p> <p>2 pares de soportes de acero recubierto epoxi para fijación a pared para cod. 7M5170. (Tornillos no incluidos)</p> <p>2 Paar Wandbefestigungen aus pulverbeschichtetem Stahl für Art. 7M5170. (Schrauben nicht inkludiert)</p>
	<b>7M5159-GA</b>	Grigio argento Silver grey Gris argenté Gris plata Silbergrau	<b>2 coppie / 2 pairs</b> <b>2 paires / 2 pares</b> <b>2 Paar</b>	<p>2 coppie in acciaio verniciato con polveri epossidiche per fissaggio a pavimento/soffitto per cod. 7M5170. (Viti non incluse)</p> <p>2 pairs of powder-coated steel supports for floor/ceiling fixing for code 7M5170. (Screws not included)</p> <p>2 paires de supports en acier peint époxy pour fixation sol/plafond pour réf. 7M5170. (Vis pas incluses)</p> <p>2 pares de soportes de acero recubierto epoxi para fijación suelo/techo para cod. 7M5170. (Tornillos no incluidos)</p> <p>2 Paar Decken/Bodenbefestigungen aus pulverbeschichtetem Stahl für Art. 7M5170. (Schrauben nicht inkludiert)</p>
	<b>7M5140</b>	Grigio argento Silver grey Gris argenté Gris plata Silbergrau	<b>1 coppia / 1 pair</b> <b>1 paire / 1 par</b> <b>1 Paar</b>	<p>1 coppia supporti in acciaio verniciato con polveri epossidiche per fissaggio a parete per cod. 7M5170. (Viti non incluse)</p> <p>1 pair of powder-coated steel supports for wall fixing for code 7M5170. (Screws not included)</p> <p>1 paire de supports en acier peint époxy pour fixation murale pour réf. 7M5170. (Vis pas incluses)</p> <p>1 par de soportes de acero recubierto epoxi para fijación a pared para cod. 7M5170. (Tornillos no incluidos)</p> <p>1 Paar Wandbefestigungen aus pulverbeschichtetem Stahl für Art. 7M5170. (Schrauben nicht inkludiert)</p>
	<b>7M5142</b>	Grigio argento Silver grey Gris argenté Gris plata Silbergrau	<b>1 coppia / 1 pair</b> <b>1 paire / 1 par</b> <b>1 Paar</b>	<p>1 coppia supporti in acciaio verniciato con polveri epossidiche per fissaggio a pavimento/soffitto per cod. 7M5170. (Viti non incluse)</p> <p>1 pair of powder-coated steel supports for floor/ceiling fixing for code 7M5170. (Screws not included)</p> <p>1 paire de supports en acier peint époxy pour fixation sol/plafon pour réf. 7M5170. (Vis pas incluses)</p> <p>1 par de soportes de acero recubierto epoxi para fijación a suelo/techo para cod. 7M5170. (Tornillos no incluidos)</p> <p>1 Paar Decken/Bodenbefestigungen aus pulverbeschichtetem Stahl für Art. 7M5170. (Schrauben nicht inkludiert)</p>



# MITESCO ON CABLES

design Michele De Lucchi  
Snowsound® technology by Caimi Brevetti

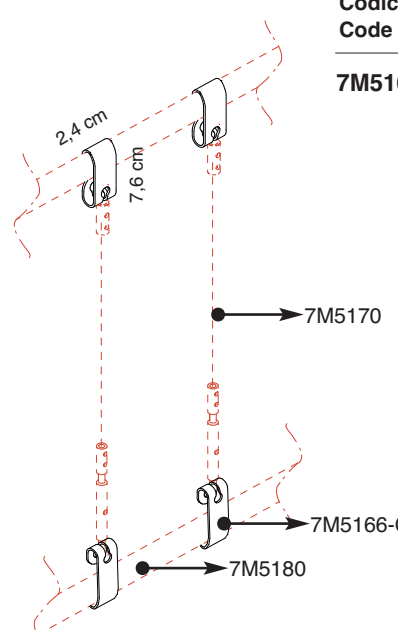
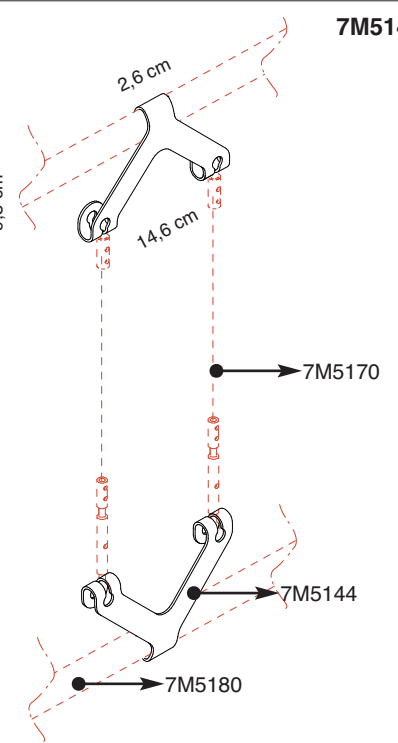
	Codice Code	Colore Colour	Prezzo Price	Descrizione Description
	<b>7M5166-GA</b>	Grigio argento Silver grey Gris argenté Gris plata Silbergrau	<b>2 coppie / 2 pairs</b> <b>2 paires / 2 pares</b> <b>2 Paar</b>	2 coppie supporti in acciaio verniciato con polveri epossidiche per cod. 7M5180 e 7M5170
				2 paires de supports en acier peint époxy pour réf. 7M5180 et 7M5170
	<b>7M5144</b>	Grigio argento Silver grey Gris argenté Gris plata Silbergrau	<b>1 coppia / 1 pair</b> <b>1 paire / 1 par</b> <b>1 Paar</b>	1 coppia supporti in acciaio verniciato con polveri epossidiche per cod. 7M5180 e 7M5170.
				1 pair of powder-coated steel supports for code 7M5180 and 7M5170
				1 paire de supports en acier peint epoxy pour réf. 7M5180 et 7M5170
				1 par de soportes de acero recubierto epoxi para cod. 7M5180 y 7M5170
				1 Paar Befestigungshaken aus pulverbeschichtetem Stahl für Art. 7M5180 und 7M5170



# MITESCO ON CABLES

design Michele De Lucchi  
Snowsound® technology by Caimi Brevetti

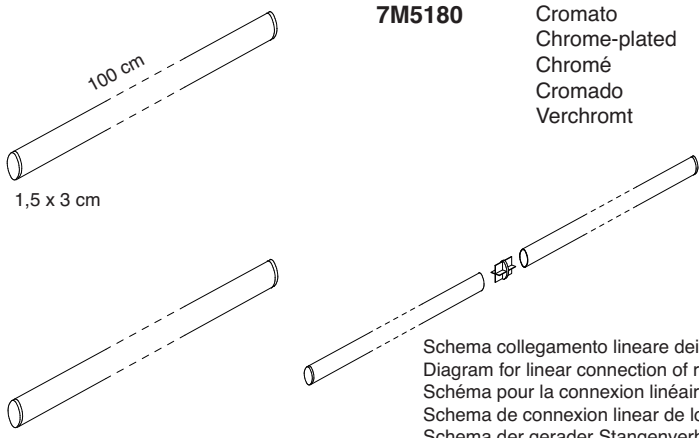
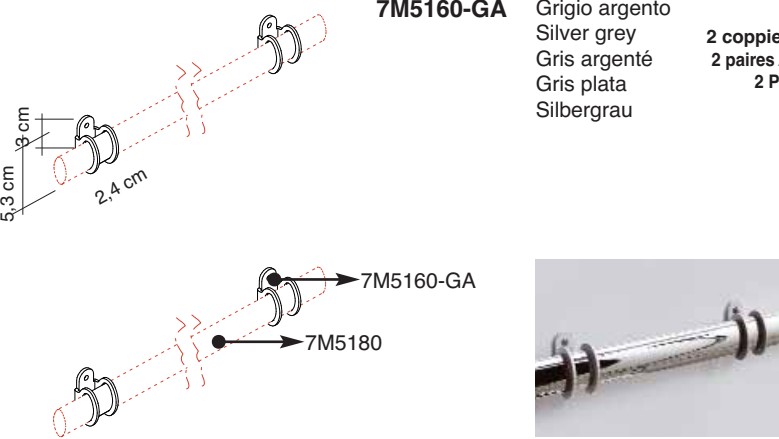
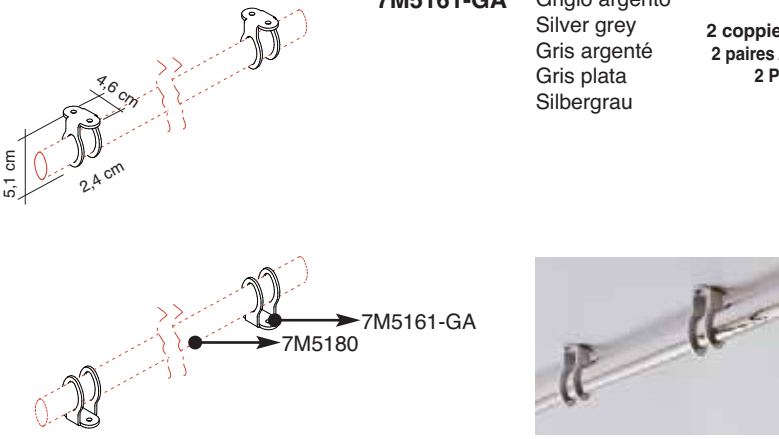
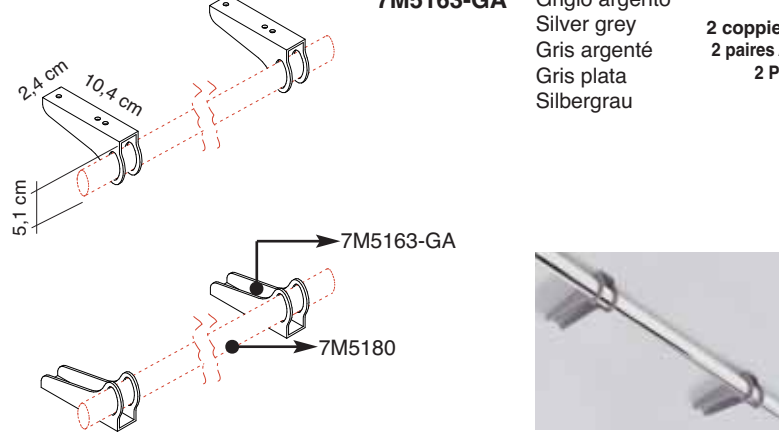
	Codice Code	Colore Colour	Prezzo Price	Descrizione Description
 <p>100 cm 1,5 x 3 cm</p> <p>Schema collegamento lineare dei tubi Diagram for linear connection of rails Schéma pour la connexion linéaire des tubes Schema de connexion linear de los tubos Schema der gerader Stangenverbindung</p>	<b>7M5180</b>	Cromato Chrome-plated Chromé Cromado Verchromt	<b>1 coppia / 1 pair</b> <b>1 paire / 1 par</b> <b>1 Paar</b>	Coppia tubi ellittici in acciaio cromato completi di giunto per collegamento lineare. Pair of elliptical rails in chrome-plated steel with joint for linear connection Paire de tubes elliptiques en acier chromé avec jonction pour connexion linéaire Par de tubos elícticos de acero cromado con enganche para enlace linear incluido 1 Paar ovale Stangen aus verchromtem Stahl mit geradem Verbindungsstück
 <p>5,3 cm 2,4 cm</p> <p>7M5160-GA 7M5180</p>	<b>7M5160-GA</b>	Grigio argento Silver grey Gris argenté Gris plata Silbergrau	<b>2 coppie / 2 pairs</b> <b>2 paires / 2 pares</b> <b>2 Paar</b>	2 coppie fissaggi a parete in acciaio verniciato con polveri epossidiche per cod. 7M5180. (Viti non incluse) 2 pairs of powder-coated steel wall connections for code 7M5180. (Screws not included) 2 paires de fixations murales en acier peint époxy pour réf. 7M5180. (Vis pas incluses) 2 pares de soportes a pared de acero recubierto epoxi para cod. 7M5180. (Tornillos no incluidos) 2 Paar Wandbefestigungen aus pulverbeschichtetem Stahl für Art. 7M5180. (Schrauben nicht inkludiert)
 <p>5,1 cm 2,4 cm 4,6 cm</p> <p>7M5161-GA 7M5180</p>	<b>7M5161-GA</b>	Grigio argento Silver grey Gris argenté Gris plata Silbergrau	<b>2 coppie / 2 pairs</b> <b>2 paires / 2 pares</b> <b>2 Paar</b>	2 coppie fissaggi a soffitto/pavimento in acciaio verniciato con polveri epossidiche per cod. 7M5180. (Viti non incluse) 2 pairs of powder-coated steel floor/ceiling connections for code 7M5180. (Screws not included) 2 paires de fixations sol/plafond en acier peint époxy pour réf. 7M5180. (Vis pas incluses) 2 pares de soportes suelo/techo de acero recubierto epoxi para cod. 7M5180. (Tornillos no incluidos) 2 Paar Decken/Bodenbefestigungen aus pulverbeschichtetem Stahl für Art. 7M5180. (Schrauben nicht inkludiert)
 <p>5,1 cm 2,4 cm 10,4 cm</p> <p>7M5163-GA 7M5180</p>	<b>7M5163-GA</b>	Grigio argento Silver grey Gris argenté Gris plata Silbergrau	<b>2 coppie / 2 pairs</b> <b>2 paires / 2 pares</b> <b>2 Paar</b>	2 coppie fissaggi a soffitto/pavimento in acciaio verniciato con polveri epossidiche per cod. 7M5180. (Viti non incluse) 2 pairs of powder-coated steel floor/ceiling connections for code 7M5180. (Screws not included) 2 paires de fixations sol/plafond en acier peint époxy pour réf. 7M5180. (Vis pas incluses) 2 pares de soportes suelo/techo de acero recubierto epoxi para cod. 7M5180. (Tornillos no incluidos) 2 Paar Decken/Bodenbefestigungen aus pulverbeschichtetem Stahl für Art. 7M5180. (Schrauben nicht inkludiert)

# MITESCO TOTEM

design Michele De Lucchi  
Snowsound® technology by Caimi Brevetti

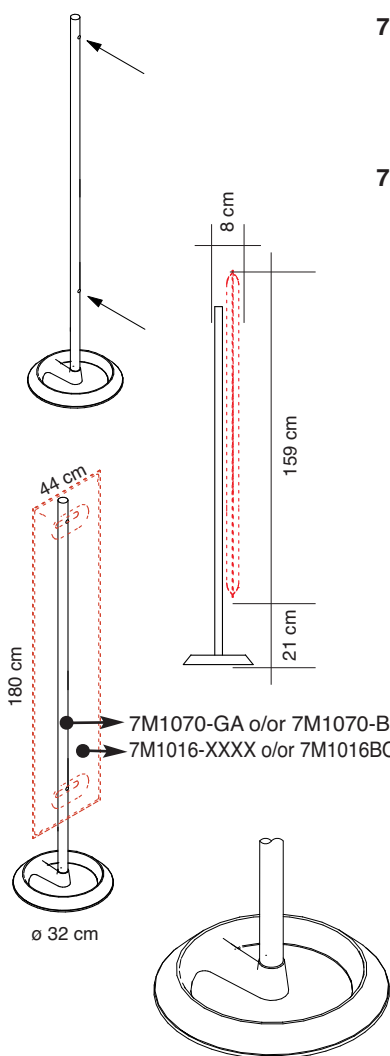
	Codice Code	Colore Colour	Prezzo Price	Descrizione Description
 <p>180 cm</p> <p>44 cm</p> <p>159 cm</p> <p>21 cm</p> <p>8 cm</p> <p>ø 32 cm</p> <p>7M1070-GA o/or 7M1070-BO 7M1016-XXXX o/or 7M1016BO-XXXX</p> <p>Dettaglio della base Detail of the base Détail de la base Detalle de la base Details der Basis</p>	<b>7M1070-GA</b>	Grigio argento Silver grey Gris argenté Gris plata Silbergrau		Struttura in acciaio verniciato con polveri epossidiche con base in ghisa verniciata con polveri epossidiche per il montaggio di 1 pannello Mitesco 7M1016-XXXX, 7M1016BO-XXXX (XXXX = Variante colore).
	<b>7M1070-BO</b>	Bianco opaco Mat white Blanc mat Blanco mate Mattweiß		Structure in powder-coated steel with base in powder-coated cast iron to mount 1 Mitesco panel code 7M1016-XXXX, 7M1016BO-XXXX (XXXX = colour option).  Structure en acier peint époxy avec base en fonte peinte époxy pour le montage de 1 panneau Mitesco réf. 7M1016-XXXX, 7M1016BO-XXXX (XXXX = option couleur)  Estructura de acero recubierto epoxi con base de hierro fundido recubierto epoxi para el montaje de 1 panel Mitesco 7M1016-XXXX, 7M1016BO-XXXX (XXXX = Variante color).  Standsäule aus pulverbeschichtetem Stahl mit Standfuß aus pulverbeschichtetem Gusseisen zur Aufstellung von 1 Mitesco-Panel Art. 7M1016-XXXX, 7M1016BO-XXXX (XXXX = Farbvariante).



 <p>15 cm</p>	<b>7M1697</b>	Alluminio lucidato Polished aluminium Aluminium poli Aluminio pulido Poliertem Aluminium		Gancio portabiti in alluminio lucidato per strutture cod. 7M1070-GA e 7M1070-BO. <b>OPZIONALE</b>  Polished aluminium hook for structures code 7M1070-GA e 7M1070-BO. <b>OPTIONAL</b>  Crochet en aluminium poli pour structures code 7M1070-GA e 7M1070-BO. <b>OPTIONNEL</b>  Gancho en aluminio pulido para estructuras code 7M1070-GA e 7M1070-BO. <b>OPCIONAL</b>  Haken aus poliertem Aluminium für Standsäule Art 7M1070-GA e 7M1070-BO. <b>OPTIONAL erhältlich</b>
	 			

# MITESCO TOTEM

design Michele De Lucchi  
Snowsound® technology by Caimi Brevetti

Codice Code	Colore Colour	Prezzo Price	Descrizione Description
----------------	------------------	-----------------	----------------------------

**7M1072-GA** Grigio argento  
Silver grey  
Gris argenté  
Gris plata  
Silbergrau

**7M1072-BO** Bianco opaco  
Mat white  
Blanc mat  
Blanco mate  
Mattweiß

Struttura in acciaio verniciato con polveri epossidiche con base in ghisa verniciata con polveri epossidiche per il montaggio di **2** pannelli Mitesco (1 pannello per lato)  
7M1016-XXXX, 7M1016BO-XXXX  
(XXXX = Variante colore).

Structure in powder-coated steel with base in powder-coated cast iron to mount **2** Mitesco panels (1 panel on each side)  
code 7M1016-XXXX, 7M1016BO-XXXX  
(XXXX = colour option).

Structure en acier peint époxy avec base en fonte peinte époxy pour le montage de **2** panneaux Mitesco (1 de chaque côté) réf. 7M1016-XXXX, 7M1016BO-XXXX  
(XXXX = option couleur)

Estructura de acero recubierto epoxi con base de hierro fundido recubierto epoxi para el montaje de **2** panels Mitesco (1 por cada lado) 7M1016-XXXX, 7M1016BO-XXXX  
(XXXX = Variante color).

Standsäule aus pulverbeschichtetem Stahl mit Standfuß aus pulverbeschichtetem Gusseisen zur Aufstellung von **2** Mitesco-Paneelen (1 pro Seite) Art. 7M1016-XXXX, 7M1016BO-XXXX (XXXX = Farbvariante).

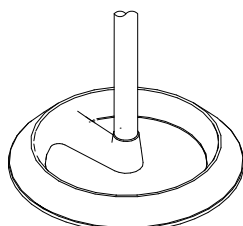
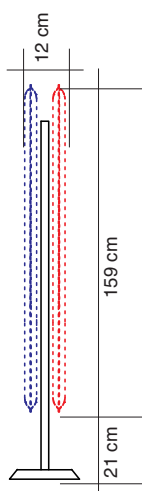
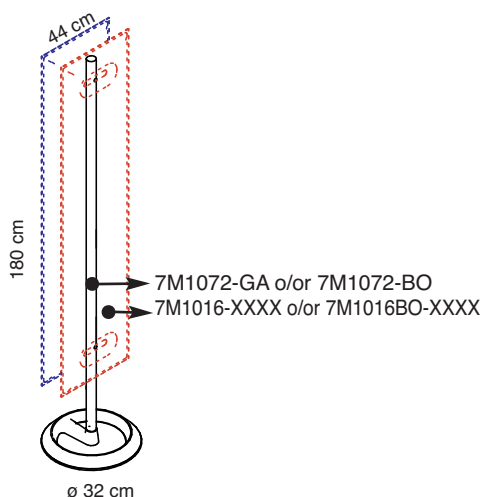
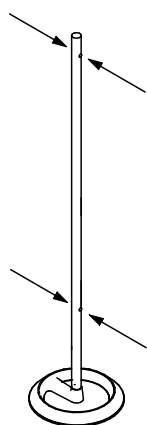

Dettaglio della base  
Detail of the base  
Détail de la base  
Detalle de la base  
Details der Basis



# MITESCO DIVIDER

design Michele De Lucchi  
Snowsound® technology by Caimi Brevetti



Per / for  
7M3650-XX / 7M3250-XX / 7M3850-XX  
7M3630-XX / 7M3230-XX / 7M3830-XX  
7M3625-XX / 7M3225-XX / 7M3825-XX



# MITESCO DIVIDER

design Michele De Lucchi  
Snowsound® technology by Caimi Brevetti

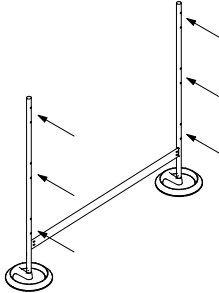
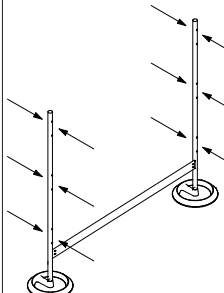
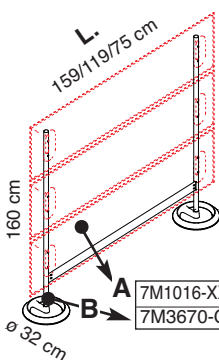
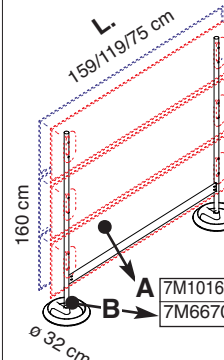
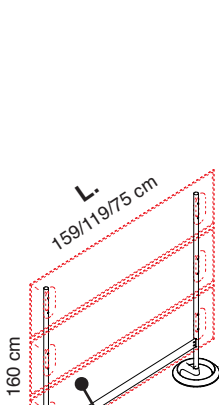
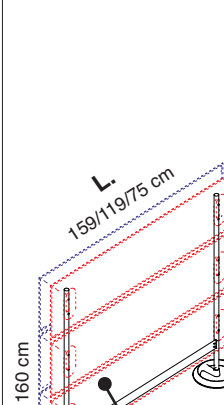
	Codice Code	Colore Colour	Prezzo Price		Codice Code	Colore Colour	Prezzo Price																																										
<b>STRUTTURA MONOFRONTA</b>  <b>ONE-SIDED FRAME</b>  	<b>7M3670-GA</b>	Grigio argento Silver grey Gris argenté Gris plata Silbergrau	Per pannelli For panels <b>L. 159 cm</b>		<b>7M6670-GA</b>	Grigio argento Silver grey Gris argenté Gris plata Silbergrau	Per pannelli For panels <b>L. 159 cm</b>																																										
	<b>7M3670-BO</b>	Bianco opaco Mat white Blanc mat Blanco mate Mattweiß	Per pannelli For panels <b>L. 159 cm</b>		<b>7M6670-BO</b>	Bianco opaco Mat white Blanc mat Blanco mate Mattweiß	Per pannelli For panels <b>L. 159 cm</b>																																										
	<b>7M3270-GA</b>	Grigio argento Silver grey Gris argenté Gris plata Silbergrau	Per pannelli For panels <b>L. 119 cm</b>		<b>7M6270-GA</b>	Grigio argento Silver grey Gris argenté Gris plata Silbergrau	Per pannelli For panels <b>L. 119 cm</b>																																										
	<b>7M3270-BO</b>	Bianco opaco Mat white Blanc mat Blanco mate Mattweiß	Per pannelli For panels <b>L. 119 cm</b>		<b>7M6270-BO</b>	Bianco opaco Mat white Blanc mat Blanco mate Mattweiß	Per pannelli For panels <b>L. 119 cm</b>																																										
	<b>7M3870-GA</b>	Grigio argento Silver grey Gris argenté Gris plata Silbergrau	Per pannelli For panels <b>L. 75 cm</b>		<b>7M6870-GA</b>	Grigio argento Silver grey Gris argenté Gris plata Silbergrau	Per pannelli For panels <b>L. 75 cm</b>																																										
	<b>7M3870-BO</b>	Bianco opaco Mat white Blanc mat Blanco mate Mattweiß	Per pannelli For panels <b>L. 75 cm</b>		<b>7M6870-BO</b>	Bianco opaco Mat white Blanc mat Blanco mate Mattweiß	Per pannelli For panels <b>L. 75 cm</b>																																										
		<table border="1"> <tr> <td>A</td> <td>7M1016-XXXX o/or 7M1016BO-XXXX</td> <td rowspan="2"><b>L. 159 cm</b></td> </tr> <tr> <td>B</td> <td>7M3670-GA o/or 7M3670-BO</td> </tr> <tr> <td colspan="3" style="text-align: center;">o/or</td> </tr> <tr> <td>A</td> <td>7M1012-XXXX o/or 7M1012BO-XXXX</td> <td rowspan="2"><b>L. 119 cm</b></td> </tr> <tr> <td>B</td> <td>7M3270-GA o/or 7M3270-BO</td> </tr> <tr> <td colspan="3" style="text-align: center;">o/or</td> </tr> <tr> <td>A</td> <td>7M1008-XXXX o/or 7M1008BO-XXXX</td> <td rowspan="2"><b>L. 75 cm</b></td> </tr> <tr> <td>B</td> <td>7M3870-GA o/or 7M3870-BO</td> </tr> </table>			A	7M1016-XXXX o/or 7M1016BO-XXXX	<b>L. 159 cm</b>	B	7M3670-GA o/or 7M3670-BO	o/or			A	7M1012-XXXX o/or 7M1012BO-XXXX	<b>L. 119 cm</b>	B	7M3270-GA o/or 7M3270-BO	o/or			A	7M1008-XXXX o/or 7M1008BO-XXXX	<b>L. 75 cm</b>	B	7M3870-GA o/or 7M3870-BO		<table border="1"> <tr> <td>A</td> <td>7M1016-XXXX o/or 7M1016BO-XXXX</td> <td rowspan="2"><b>L. 159 cm</b></td> </tr> <tr> <td>B</td> <td>7M6670-GA o/or 7M6670-BO</td> </tr> <tr> <td colspan="3" style="text-align: center;">o/or</td> </tr> <tr> <td>A</td> <td>7M1012-XXXX o/or 7M1012BO-XXXX</td> <td rowspan="2"><b>L. 119 cm</b></td> </tr> <tr> <td>B</td> <td>7M6270-GA o/or 7M6270-BO</td> </tr> <tr> <td colspan="3" style="text-align: center;">o/or</td> </tr> <tr> <td>A</td> <td>7M1008-XXXX o/or 7M1008BO-XXXX</td> <td rowspan="2"><b>L. 75 cm</b></td> </tr> <tr> <td>B</td> <td>7M6870-GA o/or 7M6870-BO</td> </tr> </table>		A	7M1016-XXXX o/or 7M1016BO-XXXX	<b>L. 159 cm</b>	B	7M6670-GA o/or 7M6670-BO	o/or			A	7M1012-XXXX o/or 7M1012BO-XXXX	<b>L. 119 cm</b>	B	7M6270-GA o/or 7M6270-BO	o/or			A	7M1008-XXXX o/or 7M1008BO-XXXX	<b>L. 75 cm</b>	B	7M6870-GA o/or 7M6870-BO
	A	7M1016-XXXX o/or 7M1016BO-XXXX	<b>L. 159 cm</b>																																														
	B	7M3670-GA o/or 7M3670-BO																																															
	o/or																																																
A	7M1012-XXXX o/or 7M1012BO-XXXX	<b>L. 119 cm</b>																																															
B	7M3270-GA o/or 7M3270-BO																																																
o/or																																																	
A	7M1008-XXXX o/or 7M1008BO-XXXX	<b>L. 75 cm</b>																																															
B	7M3870-GA o/or 7M3870-BO																																																
A	7M1016-XXXX o/or 7M1016BO-XXXX	<b>L. 159 cm</b>																																															
B	7M6670-GA o/or 7M6670-BO																																																
o/or																																																	
A	7M1012-XXXX o/or 7M1012BO-XXXX	<b>L. 119 cm</b>																																															
B	7M6270-GA o/or 7M6270-BO																																																
o/or																																																	
A	7M1008-XXXX o/or 7M1008BO-XXXX	<b>L. 75 cm</b>																																															
B	7M6870-GA o/or 7M6870-BO																																																
	<table border="1"> <tr> <td>A</td> <td>7M1016-XXXX o/or 7M1016BO-XXXX</td> <td rowspan="2"><b>L. 159 cm</b></td> </tr> <tr> <td>B</td> <td>7M3670-GA o/or 7M3670-BO</td> </tr> <tr> <td colspan="3" style="text-align: center;">o/or</td> </tr> <tr> <td>A</td> <td>7M1012-XXXX o/or 7M1012BO-XXXX</td> <td rowspan="2"><b>L. 119 cm</b></td> </tr> <tr> <td>B</td> <td>7M3270-GA o/or 7M3270-BO</td> </tr> <tr> <td colspan="3" style="text-align: center;">o/or</td> </tr> <tr> <td>A</td> <td>7M1008-XXXX o/or 7M1008BO-XXXX</td> <td rowspan="2"><b>L. 75 cm</b></td> </tr> <tr> <td>B</td> <td>7M3870-GA o/or 7M3870-BO</td> </tr> </table>		A	7M1016-XXXX o/or 7M1016BO-XXXX	<b>L. 159 cm</b>	B	7M3670-GA o/or 7M3670-BO	o/or			A	7M1012-XXXX o/or 7M1012BO-XXXX	<b>L. 119 cm</b>	B	7M3270-GA o/or 7M3270-BO	o/or			A	7M1008-XXXX o/or 7M1008BO-XXXX	<b>L. 75 cm</b>	B	7M3870-GA o/or 7M3870-BO		<table border="1"> <tr> <td>A</td> <td>7M1016-XXXX o/or 7M1016BO-XXXX</td> <td rowspan="2"><b>L. 159 cm</b></td> </tr> <tr> <td>B</td> <td>7M6670-GA o/or 7M6670-BO</td> </tr> <tr> <td colspan="3" style="text-align: center;">o/or</td> </tr> <tr> <td>A</td> <td>7M1012-XXXX o/or 7M1012BO-XXXX</td> <td rowspan="2"><b>L. 119 cm</b></td> </tr> <tr> <td>B</td> <td>7M6270-GA o/or 7M6270-BO</td> </tr> <tr> <td colspan="3" style="text-align: center;">o/or</td> </tr> <tr> <td>A</td> <td>7M1008-XXXX o/or 7M1008BO-XXXX</td> <td rowspan="2"><b>L. 75 cm</b></td> </tr> <tr> <td>B</td> <td>7M6870-GA o/or 7M6870-BO</td> </tr> </table>		A	7M1016-XXXX o/or 7M1016BO-XXXX	<b>L. 159 cm</b>	B	7M6670-GA o/or 7M6670-BO	o/or			A	7M1012-XXXX o/or 7M1012BO-XXXX	<b>L. 119 cm</b>	B	7M6270-GA o/or 7M6270-BO	o/or			A	7M1008-XXXX o/or 7M1008BO-XXXX	<b>L. 75 cm</b>	B	7M6870-GA o/or 7M6870-BO		
A	7M1016-XXXX o/or 7M1016BO-XXXX	<b>L. 159 cm</b>																																															
B	7M3670-GA o/or 7M3670-BO																																																
o/or																																																	
A	7M1012-XXXX o/or 7M1012BO-XXXX	<b>L. 119 cm</b>																																															
B	7M3270-GA o/or 7M3270-BO																																																
o/or																																																	
A	7M1008-XXXX o/or 7M1008BO-XXXX	<b>L. 75 cm</b>																																															
B	7M3870-GA o/or 7M3870-BO																																																
A	7M1016-XXXX o/or 7M1016BO-XXXX	<b>L. 159 cm</b>																																															
B	7M6670-GA o/or 7M6670-BO																																																
o/or																																																	
A	7M1012-XXXX o/or 7M1012BO-XXXX	<b>L. 119 cm</b>																																															
B	7M6270-GA o/or 7M6270-BO																																																
o/or																																																	
A	7M1008-XXXX o/or 7M1008BO-XXXX	<b>L. 75 cm</b>																																															
B	7M6870-GA o/or 7M6870-BO																																																

Struttura in acciaio verniciato con polveri epossidiche con basi in ghisa verniciata con polveri epossidiche per il montaggio di 3 o 6 pannelli Mitesco.

Structure in powder-coated steel with bases in powder-coated cast iron to mount 3 or 6 Mitesco panels.

Structure en acier peint époxy avec bases en fonte peinte époxy pour le montage de 3 ou 6 panneaux Mitesco.

Estructura de acero recubierto epoxi con bases de hierro fundido recubierto epoxi para el montaje de 3 o 6 paneles Mitesco.

Standsäulen aus pulverbeschichtetem Stahl mit Standfuß aus pulverbeschichtetem Gusseisen zur Aufstellung von 3 oder 6 Mitesco-Paneelen.

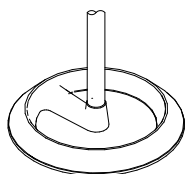

Dettaglio della base  
Detail of the base  
Détail de la base  
Detalle de la base  
Details der Basis

# MITESCO DIVIDER

design Michele De Lucchi  
Snowsound® technology by Caimi Brevetti

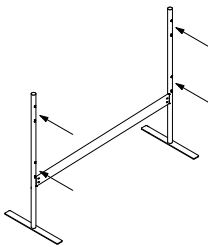
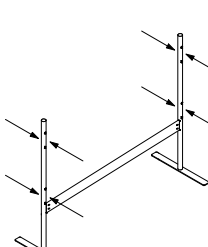
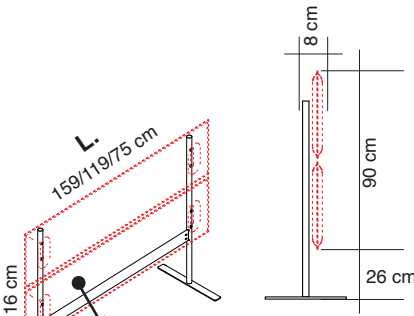
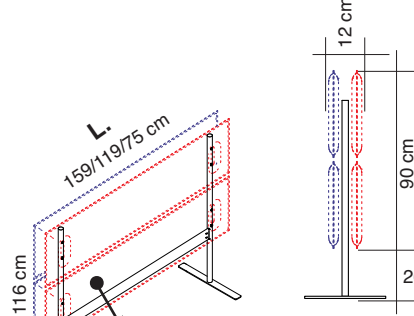
	Codice Code	Colore Colour	Prezzo Price		Codice Code	Colore Colour	Prezzo Price																																												
<b>STRUTTURA MONOFRONTA</b>  <b>ONE-SIDED FRAME</b>  	<b>7M0650-GA</b>	Grigio argento Silver grey Gris argenté Gris plata Silbergrau	Per pannelli For panels <b>L. 159 cm</b>	<b>STRUTTURA BIFRONTA</b>  <b>DOUBLE-SIDED FRAME</b>  	<b>7M2650-GA</b>	Grigio argento Silver grey Gris argenté Gris plata Silbergrau	Per pannelli For panels <b>L. 159 cm</b>																																												
	<b>7M0650-BO</b>	Bianco opaco Mat white Blanc mat Blanco mate Mattweiß	Per pannelli For panels <b>L. 159 cm</b>		<b>7M2650-BO</b>	Bianco opaco Mat white Blanc mat Blanco mate Mattweiß	Per pannelli For panels <b>L. 159 cm</b>																																												
	<b>7M0250-GA</b>	Grigio argento Silver grey Gris argenté Gris plata Silbergrau	Per pannelli For panels <b>L. 119 cm</b>		<b>7M2250-GA</b>	Grigio argento Silver grey Gris argenté Gris plata Silbergrau	Per pannelli For panels <b>L. 119 cm</b>																																												
	<b>7M0250-BO</b>	Bianco opaco Mat white Blanc mat Blanco mate Mattweiß	Per pannelli For panels <b>L. 119 cm</b>		<b>7M2250-BO</b>	Bianco opaco Mat white Blanc mat Blanco mate Mattweiß	Per pannelli For panels <b>L. 119 cm</b>																																												
	<b>7M0850-GA</b>	Grigio argento Silver grey Gris argenté Gris plata Silbergrau	Per pannelli For panels <b>L. 75 cm</b>		<b>7M2850-GA</b>	Grigio argento Silver grey Gris argenté Gris plata Silbergrau	Per pannelli For panels <b>L. 75 cm</b>																																												
	<b>7M0850-BO</b>	Bianco opaco Mat white Blanc mat Blanco mate Mattweiß	Per pannelli For panels <b>L. 75 cm</b>		<b>7M2850-BO</b>	Bianco opaco Mat white Blanc mat Blanco mate Mattweiß	Per pannelli For panels <b>L. 75 cm</b>																																												
			<table border="1"> <tr> <td><b>A</b></td> <td>7M1016-XXXX o/or 7M1016BO-XXXX</td> <td rowspan="2"><b>L. 159 cm</b></td> </tr> <tr> <td><b>B</b></td> <td>7M0650-GA o/or 7M0650-BO</td> </tr> <tr> <td colspan="3" style="text-align: center;">o/or</td> </tr> <tr> <td><b>A</b></td> <td>7M1012-XXXX o/or 7M1012BO-XXXX</td> <td rowspan="2"><b>L. 119 cm</b></td> </tr> <tr> <td><b>B</b></td> <td>7M0250-GA o/or 7M0250-BO</td> </tr> <tr> <td colspan="3" style="text-align: center;">o/or</td> </tr> <tr> <td><b>A</b></td> <td>7M1008-XXXX o/or 7M1008BO-XXXX</td> <td rowspan="2"><b>L. 75 cm</b></td> </tr> <tr> <td><b>B</b></td> <td>7M0850-GA o/or 7M0850-BO</td> </tr> </table>		<b>A</b>	7M1016-XXXX o/or 7M1016BO-XXXX	<b>L. 159 cm</b>	<b>B</b>	7M0650-GA o/or 7M0650-BO	o/or			<b>A</b>	7M1012-XXXX o/or 7M1012BO-XXXX	<b>L. 119 cm</b>	<b>B</b>	7M0250-GA o/or 7M0250-BO	o/or			<b>A</b>	7M1008-XXXX o/or 7M1008BO-XXXX	<b>L. 75 cm</b>	<b>B</b>	7M0850-GA o/or 7M0850-BO			<table border="1"> <tr> <td><b>A</b></td> <td>7M1016-XXXX o/or 7M1016BO-XXXX</td> <td rowspan="2"><b>L. 159 cm</b></td> </tr> <tr> <td><b>B</b></td> <td>7M2650-GA o/or 7M2650-BO</td> </tr> <tr> <td colspan="3" style="text-align: center;">o/or</td> </tr> <tr> <td><b>A</b></td> <td>7M1012-XXXX o/or 7M1012BO-XXXX</td> <td rowspan="2"><b>L. 119 cm</b></td> </tr> <tr> <td><b>B</b></td> <td>7M2250-GA o/or 7M2250-BO</td> </tr> <tr> <td colspan="3" style="text-align: center;">o/or</td> </tr> <tr> <td><b>A</b></td> <td>7M1008-XXXX o/or 7M1008BO-XXXX</td> <td rowspan="2"><b>L. 75 cm</b></td> </tr> <tr> <td><b>B</b></td> <td>7M2850-GA o/or 7M2850-BO</td> </tr> </table>		<b>A</b>	7M1016-XXXX o/or 7M1016BO-XXXX	<b>L. 159 cm</b>	<b>B</b>	7M2650-GA o/or 7M2650-BO	o/or			<b>A</b>	7M1012-XXXX o/or 7M1012BO-XXXX	<b>L. 119 cm</b>	<b>B</b>	7M2250-GA o/or 7M2250-BO	o/or			<b>A</b>	7M1008-XXXX o/or 7M1008BO-XXXX	<b>L. 75 cm</b>	<b>B</b>	7M2850-GA o/or 7M2850-BO	
	<b>A</b>	7M1016-XXXX o/or 7M1016BO-XXXX	<b>L. 159 cm</b>																																																
	<b>B</b>	7M0650-GA o/or 7M0650-BO																																																	
	o/or																																																		
<b>A</b>	7M1012-XXXX o/or 7M1012BO-XXXX	<b>L. 119 cm</b>																																																	
<b>B</b>	7M0250-GA o/or 7M0250-BO																																																		
o/or																																																			
<b>A</b>	7M1008-XXXX o/or 7M1008BO-XXXX	<b>L. 75 cm</b>																																																	
<b>B</b>	7M0850-GA o/or 7M0850-BO																																																		
<b>A</b>	7M1016-XXXX o/or 7M1016BO-XXXX	<b>L. 159 cm</b>																																																	
<b>B</b>	7M2650-GA o/or 7M2650-BO																																																		
o/or																																																			
<b>A</b>	7M1012-XXXX o/or 7M1012BO-XXXX	<b>L. 119 cm</b>																																																	
<b>B</b>	7M2250-GA o/or 7M2250-BO																																																		
o/or																																																			
<b>A</b>	7M1008-XXXX o/or 7M1008BO-XXXX	<b>L. 75 cm</b>																																																	
<b>B</b>	7M2850-GA o/or 7M2850-BO																																																		

Struttura in acciaio verniciato con polveri epossidiche con basi in acciaio verniciato con polveri epossidiche per il montaggio di 2 o 4 pannelli Mitesco.

Structure in powder-coated steel with bases in powder-coated steel to mount 2 ou 4 Mitesco panels.

Structure en acier peint époxy avec bases en acier peint époxy pour le montage de 2 ou 4 panneaux Mitesco.

Estructura de acero recubierto epoxi con bases de acero recubierto epoxi para el montaje de 2 o 4 paneles Mitesco.

Standssäulen aus pulverbeschichtetem Stahl mit Standfuß aus pulverbeschichtetem Stahl zur Aufstellung von 2 oder 4 Mitesco-Paneele.

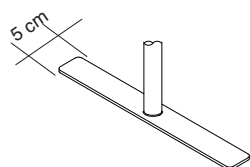

Dettaglio della base  
Detail of the base  
Détail de la base  
Detalle de la base  
Details der Basis



# MITESCO DIVIDER

design Michele De Lucchi  
Snowsound® technology by Caimi Brevetti

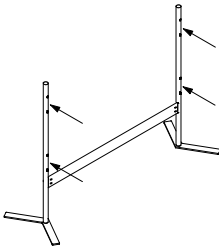
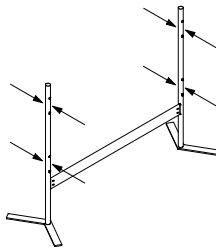
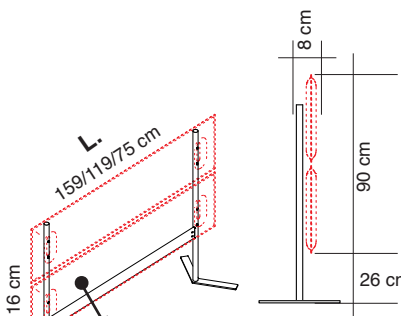
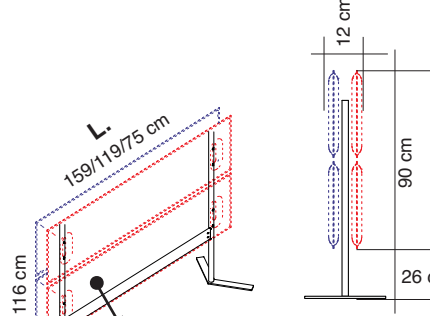
	Codice Code	Colore Colour	Prezzo Price		Codice Code	Colore Colour	Prezzo Price								
<b>STRUTTURA MONOFRONTE</b>  <b>ONE-SIDED FRAME</b>  	<b>7M0630-GA</b>	Grigio argento Silver grey Gris argenté Gris plata Silbergrau	Per pannelli For panels <b>L. 159 cm</b>	<b>STRUTTURA BIFRONTE</b>  <b>DOUBLE-SIDED FRAME</b>  	<b>7M2630-GA</b>	Grigio argento Silver grey Gris argenté Gris plata Silbergrau	Per pannelli For panels <b>L. 159 cm</b>								
	<b>7M0630-BO</b>	Bianco opaco Mat white Blanc mat Blanco mate Mattweiß	Per pannelli For panels <b>L. 159 cm</b>		<b>7M2630-BO</b>	Bianco opaco Mat white Blanc mat Blanco mate Mattweiß	Per pannelli For panels <b>L. 159 cm</b>								
	<b>7M0230-GA</b>	Grigio argento Silver grey Gris argenté Gris plata Silbergrau	Per pannelli For panels <b>L. 119 cm</b>		<b>7M2230-GA</b>	Grigio argento Silver grey Gris argenté Gris plata Silbergrau	Per pannelli For panels <b>L. 119 cm</b>								
	<b>7M0230-BO</b>	Bianco opaco Mat white Blanc mat Blanco mate Mattweiß	Per pannelli For panels <b>L. 119 cm</b>		<b>7M2230-BO</b>	Bianco opaco Mat white Blanc mat Blanco mate Mattweiß	Per pannelli For panels <b>L. 119 cm</b>								
	<b>7M0830-GA</b>	Grigio argento Silver grey Gris argenté Gris plata Silbergrau	Per pannelli For panels <b>L. 75 cm</b>		<b>7M2830-GA</b>	Grigio argento Silver grey Gris argenté Gris plata Silbergrau	Per pannelli For panels <b>L. 75 cm</b>								
	<b>7M0830-BO</b>	Bianco opaco Mat white Blanc mat Blanco mate Mattweiß	Per pannelli For panels <b>L. 75 cm</b>		<b>7M2830-BO</b>	Bianco opaco Mat white Blanc mat Blanco mate Mattweiß	Per pannelli For panels <b>L. 75 cm</b>								
															
	<table border="1"> <tr> <td><b>A</b></td> <td>7M1016-XXXX o/or 7M1016BO-XXXX</td> <td rowspan="2"><b>L. 159 cm</b></td> </tr> <tr> <td><b>B</b></td> <td>7M0630-GA o/or 7M0630-BO</td> </tr> </table>		<b>A</b>		7M1016-XXXX o/or 7M1016BO-XXXX	<b>L. 159 cm</b>	<b>B</b>	7M0630-GA o/or 7M0630-BO	<table border="1"> <tr> <td><b>A</b></td> <td>7M1016-XXXX o/or 7M1016BO-XXXX</td> <td rowspan="2"><b>L. 159 cm</b></td> </tr> <tr> <td><b>B</b></td> <td>7M2630-GA o/or 7M2630-BO</td> </tr> </table>		<b>A</b>	7M1016-XXXX o/or 7M1016BO-XXXX	<b>L. 159 cm</b>	<b>B</b>	7M2630-GA o/or 7M2630-BO
	<b>A</b>	7M1016-XXXX o/or 7M1016BO-XXXX	<b>L. 159 cm</b>												
	<b>B</b>	7M0630-GA o/or 7M0630-BO													
<b>A</b>	7M1016-XXXX o/or 7M1016BO-XXXX	<b>L. 159 cm</b>													
<b>B</b>	7M2630-GA o/or 7M2630-BO														
<table border="1"> <tr> <td><b>A</b></td> <td>7M1012-XXXX o/or 7M1012BO-XXXX</td> <td rowspan="2"><b>L. 119 cm</b></td> </tr> <tr> <td><b>B</b></td> <td>7M0230-GA o/or 7M0230-BO</td> </tr> </table>		<b>A</b>	7M1012-XXXX o/or 7M1012BO-XXXX	<b>L. 119 cm</b>	<b>B</b>	7M0230-GA o/or 7M0230-BO	<table border="1"> <tr> <td><b>A</b></td> <td>7M1012-XXXX o/or 7M1012BO-XXXX</td> <td rowspan="2"><b>L. 119 cm</b></td> </tr> <tr> <td><b>B</b></td> <td>7M2230-GA o/or 7M2230-BO</td> </tr> </table>		<b>A</b>	7M1012-XXXX o/or 7M1012BO-XXXX	<b>L. 119 cm</b>	<b>B</b>	7M2230-GA o/or 7M2230-BO		
<b>A</b>	7M1012-XXXX o/or 7M1012BO-XXXX	<b>L. 119 cm</b>													
<b>B</b>	7M0230-GA o/or 7M0230-BO														
<b>A</b>	7M1012-XXXX o/or 7M1012BO-XXXX	<b>L. 119 cm</b>													
<b>B</b>	7M2230-GA o/or 7M2230-BO														
<table border="1"> <tr> <td><b>A</b></td> <td>7M1008-XXXX o/or 7M1008BO-XXXX</td> <td rowspan="2"><b>L. 75 cm</b></td> </tr> <tr> <td><b>B</b></td> <td>7M0830-GA o/or 7M0830-BO</td> </tr> </table>		<b>A</b>	7M1008-XXXX o/or 7M1008BO-XXXX	<b>L. 75 cm</b>	<b>B</b>	7M0830-GA o/or 7M0830-BO	<table border="1"> <tr> <td><b>A</b></td> <td>7M1008-XXXX o/or 7M1008BO-XXXX</td> <td rowspan="2"><b>L. 75 cm</b></td> </tr> <tr> <td><b>B</b></td> <td>7M2830-GA o/or 7M2830-BO</td> </tr> </table>		<b>A</b>	7M1008-XXXX o/or 7M1008BO-XXXX	<b>L. 75 cm</b>	<b>B</b>	7M2830-GA o/or 7M2830-BO		
<b>A</b>	7M1008-XXXX o/or 7M1008BO-XXXX	<b>L. 75 cm</b>													
<b>B</b>	7M0830-GA o/or 7M0830-BO														
<b>A</b>	7M1008-XXXX o/or 7M1008BO-XXXX	<b>L. 75 cm</b>													
<b>B</b>	7M2830-GA o/or 7M2830-BO														

Struttura in acciaio verniciato con polveri epossidiche con basi in acciaio verniciato con polveri epossidiche per il montaggio di **2 o 4** pannelli Mitesco.

Structure in powder-coated steel with bases in powder-coated steel to mount **2 ou 4** Mitesco panels.

Structure en acier peint époxy avec bases en acier peint époxy pour le montage de **2 ou 4** panneaux Mitesco.

Estructura de acero recubierto epoxi con bases de acero recubierto epoxi para el montaje de **2 o 4** paneles Mitesco.

Standssäulen aus pulverbeschichtetem Stahl mit Standfuß aus pulverbeschichtetem Stahl zur Aufstellung von **2 oder 4** Mitesco-Paneeelen.

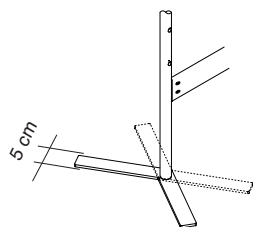

Dettaglio della base. La base può essere montata in due posizioni, interna o esterna.  
Detail of the base. The base can be mounted in two positions, internal or external.

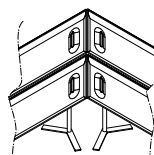

Nelle composizioni ad angolo, l'utilizzo di questa base permette il perfetto accostamento dei pannelli.  
In the corner compositions the use of this base allows the perfect approaching of the panels.

# MITESCO DIVIDER

design Michele De Lucchi  
Snowsound® technology by Caimi Brevetti

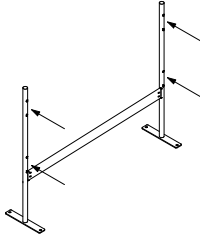
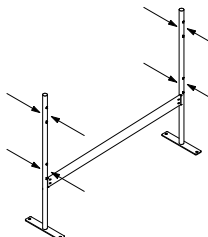
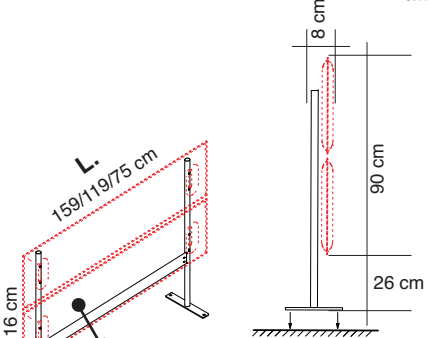
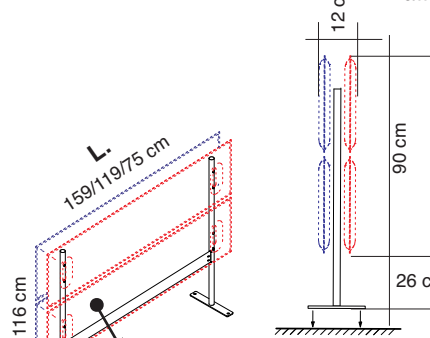
	Codice Code	Colore Colour	Prezzo Price		Codice Code	Colore Colour	Prezzo Price								
<b>STRUTTURA MONOFRONTALE</b>  <b>ONE-SIDED FRAME</b>  	<b>7M0625-GA</b>	Grigio argento Silver grey Gris argenté Gris plata Silbergrau	Per pannelli For panels <b>L. 159 cm</b>	<b>STRUTTURA BIFRONTALE</b>  <b>DOUBLE-SIDED FRAME</b>  	<b>7M2625-GA</b>	Grigio argento Silver grey Gris argenté Gris plata Silbergrau	Per pannelli For panels <b>L. 159 cm</b>								
	<b>7M0625-BO</b>	Bianco opaco Mat white Blanc mat Blanco mate Mattweiß	Per pannelli For panels <b>L. 159 cm</b>		<b>7M2625-BO</b>	Bianco opaco Mat white Blanc mat Blanco mate Mattweiß	Per pannelli For panels <b>L. 159 cm</b>								
	<b>7M0225-GA</b>	Grigio argento Silver grey Gris argenté Gris plata Silbergrau	Per pannelli For panels <b>L. 119 cm</b>		<b>7M2225-GA</b>	Grigio argento Silver grey Gris argenté Gris plata Silbergrau	Per pannelli For panels <b>L. 119 cm</b>								
	<b>7M0225-BO</b>	Bianco opaco Mat white Blanc mat Blanco mate Mattweiß	Per pannelli For panels <b>L. 119 cm</b>		<b>7M2225-BO</b>	Bianco opaco Mat white Blanc mat Blanco mate Mattweiß	Per pannelli For panels <b>L. 119 cm</b>								
	<b>7M0825-GA</b>	Grigio argento Silver grey Gris argenté Gris plata Silbergrau	Per pannelli For panels <b>L. 75 cm</b>		<b>7M2825-GA</b>	Grigio argento Silver grey Gris argenté Gris plata Silbergrau	Per pannelli For panels <b>L. 75 cm</b>								
	<b>7M0825-BO</b>	Bianco opaco Mat white Blanc mat Blanco mate Mattweiß	Per pannelli For panels <b>L. 75 cm</b>		<b>7M2825-BO</b>	Bianco opaco Mat white Blanc mat Blanco mate Mattweiß	Per pannelli For panels <b>L. 75 cm</b>								
															
	<table border="1"> <tr> <td><b>A</b></td> <td>7M1016-XXXX o/or 7M1016BO-XXXX</td> <td rowspan="2"><b>L. 159 cm</b></td> </tr> <tr> <td><b>B</b></td> <td>7M0625-GA o/or 7M0625-BO</td> </tr> </table>		<b>A</b>		7M1016-XXXX o/or 7M1016BO-XXXX	<b>L. 159 cm</b>	<b>B</b>	7M0625-GA o/or 7M0625-BO	<table border="1"> <tr> <td><b>A</b></td> <td>7M1016-XXXX o/or 7M1016BO-XXXX</td> <td rowspan="2"><b>L. 159 cm</b></td> </tr> <tr> <td><b>B</b></td> <td>7M2625-GA o/or 7M2625-BO</td> </tr> </table>		<b>A</b>	7M1016-XXXX o/or 7M1016BO-XXXX	<b>L. 159 cm</b>	<b>B</b>	7M2625-GA o/or 7M2625-BO
	<b>A</b>	7M1016-XXXX o/or 7M1016BO-XXXX	<b>L. 159 cm</b>												
	<b>B</b>	7M0625-GA o/or 7M0625-BO													
<b>A</b>	7M1016-XXXX o/or 7M1016BO-XXXX	<b>L. 159 cm</b>													
<b>B</b>	7M2625-GA o/or 7M2625-BO														
<table border="1"> <tr> <td><b>A</b></td> <td>7M1012-XXXX o/or 7M1012BO-XXXX</td> <td rowspan="2"><b>L. 119 cm</b></td> </tr> <tr> <td><b>B</b></td> <td>7M0225-GA o/or 7M0225-BO</td> </tr> </table>		<b>A</b>	7M1012-XXXX o/or 7M1012BO-XXXX	<b>L. 119 cm</b>	<b>B</b>	7M0225-GA o/or 7M0225-BO	<table border="1"> <tr> <td><b>A</b></td> <td>7M1012-XXXX o/or 7M1012BO-XXXX</td> <td rowspan="2"><b>L. 119 cm</b></td> </tr> <tr> <td><b>B</b></td> <td>7M2225-GA o/or 7M2225-BO</td> </tr> </table>		<b>A</b>	7M1012-XXXX o/or 7M1012BO-XXXX	<b>L. 119 cm</b>	<b>B</b>	7M2225-GA o/or 7M2225-BO		
<b>A</b>	7M1012-XXXX o/or 7M1012BO-XXXX	<b>L. 119 cm</b>													
<b>B</b>	7M0225-GA o/or 7M0225-BO														
<b>A</b>	7M1012-XXXX o/or 7M1012BO-XXXX	<b>L. 119 cm</b>													
<b>B</b>	7M2225-GA o/or 7M2225-BO														
<table border="1"> <tr> <td><b>A</b></td> <td>7M1008-XXXX o/or 7M1008BO-XXXX</td> <td rowspan="2"><b>L. 75 cm</b></td> </tr> <tr> <td><b>B</b></td> <td>7M0825-GA o/or 7M0825-BO</td> </tr> </table>		<b>A</b>	7M1008-XXXX o/or 7M1008BO-XXXX	<b>L. 75 cm</b>	<b>B</b>	7M0825-GA o/or 7M0825-BO	<table border="1"> <tr> <td><b>A</b></td> <td>7M1008-XXXX o/or 7M1008BO-XXXX</td> <td rowspan="2"><b>L. 75 cm</b></td> </tr> <tr> <td><b>B</b></td> <td>7M2825-GA o/or 7M2825-BO</td> </tr> </table>		<b>A</b>	7M1008-XXXX o/or 7M1008BO-XXXX	<b>L. 75 cm</b>	<b>B</b>	7M2825-GA o/or 7M2825-BO		
<b>A</b>	7M1008-XXXX o/or 7M1008BO-XXXX	<b>L. 75 cm</b>													
<b>B</b>	7M0825-GA o/or 7M0825-BO														
<b>A</b>	7M1008-XXXX o/or 7M1008BO-XXXX	<b>L. 75 cm</b>													
<b>B</b>	7M2825-GA o/or 7M2825-BO														

Struttura in acciaio verniciato con polveri epossidiche con basi in acciaio verniciato con polveri epossidiche per fissaggio a terra (viti non incluse) per il montaggio di 2 o 4 pannelli Mitesco.

Structure in powder-coated steel with powder-coated steel bases for floor fixing (screws not included), to mount 2 or 4 Mitesco panels.

Structure en acier peint époxy avec bases en acier peint époxy pour fixation au sol (vis pas incluses) pour le montage de 2 ou 4 panneaux Mitesco.

Estructura de acero recubierto epoxi con bases de acero recubierto epoxi para fijación al suelo (tornillos no incluidos) para el montaje de 2 o 4 paneles Mitesco.

Standssäulen aus pulverbeschichtetem Stahl mit Fuß zur Bodenbefestigung (Schrauben nicht inkludiert) aus pulverbeschichtetem Stahl zur Aufstellung von 2 oder 4 Mitesco-Paneele.

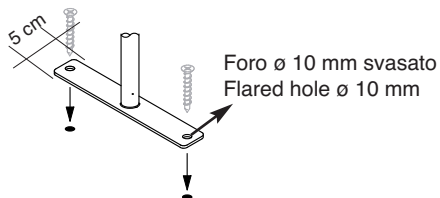

Foro ø 10 mm svasato  
Flared hole ø 10 mm

Dettaglio della base (viti non incluse)  
Detail of the base (screws not included)  
Détail de la base (vis pas incluses)  
Detalle de la base (tornillos no incluidos)  
Details der Basis (Schrauben nicht inkludiert)

# MITESCO DIVIDER

design Michele De Lucchi  
Snowsound® technology by Caimi Brevetti

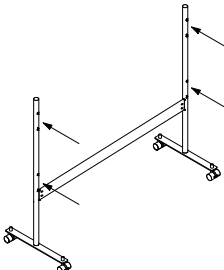
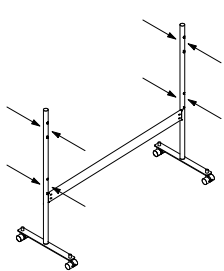
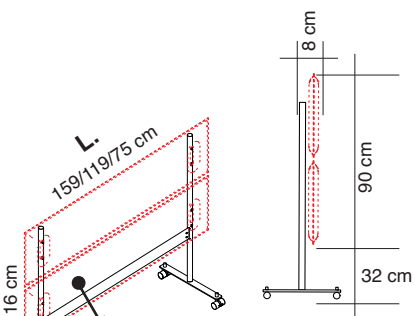
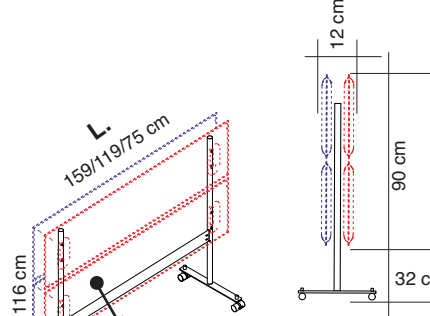
	Codice Code	Colore Colour	Prezzo Price		Codice Code	Colore Colour	Prezzo Price																																												
<b>STRUTTURA MONOFRONTALE</b>  <b>ONE-SIDED FRAME</b> 	<b>7M0660-RGA</b>	Grigio argento Silver grey Gris argenté Gris plata Silbergrau	Per pannelli For panels <b>L. 159 cm</b>	<b>STRUTTURA BIFRONTALE</b>  <b>DOUBLE-SIDED FRAME</b> 	<b>7M2660-RGA</b>	Grigio argento Silver grey Gris argenté Gris plata Silbergrau	Per pannelli For panels <b>L. 159 cm</b>																																												
	<b>7M0660-RBO</b>	Bianco opaco Mat white Blanc mat Blanco mate Mattweiß	Per pannelli For panels <b>L. 159 cm</b>		<b>7M2660-RBO</b>	Bianco opaco Mat white Blanc mat Blanco mate Mattweiß	Per pannelli For panels <b>L. 159 cm</b>																																												
	<b>7M0260-RGA</b>	Grigio argento Silver grey Gris argenté Gris plata Silbergrau	Per pannelli For panels <b>L. 119 cm</b>		<b>7M2260-RGA</b>	Grigio argento Silver grey Gris argenté Gris plata Silbergrau	Per pannelli For panels <b>L. 119 cm</b>																																												
	<b>7M0260-RBO</b>	Bianco opaco Mat white Blanc mat Blanco mate Mattweiß	Per pannelli For panels <b>L. 119 cm</b>		<b>7M2260-RBO</b>	Bianco opaco Mat white Blanc mat Blanco mate Mattweiß	Per pannelli For panels <b>L. 119 cm</b>																																												
	<b>7M0860-RGA</b>	Grigio argento Silver grey Gris argenté Gris plata Silbergrau	Per pannelli For panels <b>L. 75 cm</b>		<b>7M2860-RGA</b>	Grigio argento Silver grey Gris argenté Gris plata Silbergrau	Per pannelli For panels <b>L. 75 cm</b>																																												
	<b>7M0860-RBO</b>	Bianco opaco Mat white Blanc mat Blanco mate Mattweiß	Per pannelli For panels <b>L. 75 cm</b>		<b>7M2860-RBO</b>	Bianco opaco Mat white Blanc mat Blanco mate Mattweiß	Per pannelli For panels <b>L. 75 cm</b>																																												
			<table border="1"> <tr> <td>A</td> <td>7M1016-XXXX o/or 7M1016BO-XXXX</td> <td rowspan="2"><b>L. 159 cm</b></td> </tr> <tr> <td>B</td> <td>7M0660-RGA o/or 7M0660-RBO</td> </tr> <tr> <td colspan="3" style="text-align: center;">o/or</td> </tr> <tr> <td>A</td> <td>7M1012-XXXX o/or 7M1012BO-XXXX</td> <td rowspan="2"><b>L. 119 cm</b></td> </tr> <tr> <td>B</td> <td>7M0260-RGA o/or 7M0260-RBO</td> </tr> <tr> <td colspan="3" style="text-align: center;">o/or</td> </tr> <tr> <td>A</td> <td>7M1008-XXXX o/or 7M1008BO-XXXX</td> <td rowspan="2"><b>L. 75 cm</b></td> </tr> <tr> <td>B</td> <td>7M0860-RGA o/or 7M0860-RBO</td> </tr> </table>		A	7M1016-XXXX o/or 7M1016BO-XXXX	<b>L. 159 cm</b>	B	7M0660-RGA o/or 7M0660-RBO	o/or			A	7M1012-XXXX o/or 7M1012BO-XXXX	<b>L. 119 cm</b>	B	7M0260-RGA o/or 7M0260-RBO	o/or			A	7M1008-XXXX o/or 7M1008BO-XXXX	<b>L. 75 cm</b>	B	7M0860-RGA o/or 7M0860-RBO			<table border="1"> <tr> <td>A</td> <td>7M1016-XXXX o/or 7M1016BO-XXXX</td> <td rowspan="2"><b>L. 159 cm</b></td> </tr> <tr> <td>B</td> <td>7M2660R-GA o/or 7M2660-RBO</td> </tr> <tr> <td colspan="3" style="text-align: center;">o/or</td> </tr> <tr> <td>A</td> <td>7M1012-XXXX o/or 7M1012BO-XXXX</td> <td rowspan="2"><b>L. 119 cm</b></td> </tr> <tr> <td>B</td> <td>7M2260-RGA o/or 7M2260-RBO</td> </tr> <tr> <td colspan="3" style="text-align: center;">o/or</td> </tr> <tr> <td>A</td> <td>7M1008-XXXX o/or 7M1008BO-XXXX</td> <td rowspan="2"><b>L. 75 cm</b></td> </tr> <tr> <td>B</td> <td>7M2860-RGA o/or 7M2860-RBO</td> </tr> </table>		A	7M1016-XXXX o/or 7M1016BO-XXXX	<b>L. 159 cm</b>	B	7M2660R-GA o/or 7M2660-RBO	o/or			A	7M1012-XXXX o/or 7M1012BO-XXXX	<b>L. 119 cm</b>	B	7M2260-RGA o/or 7M2260-RBO	o/or			A	7M1008-XXXX o/or 7M1008BO-XXXX	<b>L. 75 cm</b>	B	7M2860-RGA o/or 7M2860-RBO	
	A	7M1016-XXXX o/or 7M1016BO-XXXX	<b>L. 159 cm</b>																																																
	B	7M0660-RGA o/or 7M0660-RBO																																																	
	o/or																																																		
A	7M1012-XXXX o/or 7M1012BO-XXXX	<b>L. 119 cm</b>																																																	
B	7M0260-RGA o/or 7M0260-RBO																																																		
o/or																																																			
A	7M1008-XXXX o/or 7M1008BO-XXXX	<b>L. 75 cm</b>																																																	
B	7M0860-RGA o/or 7M0860-RBO																																																		
A	7M1016-XXXX o/or 7M1016BO-XXXX	<b>L. 159 cm</b>																																																	
B	7M2660R-GA o/or 7M2660-RBO																																																		
o/or																																																			
A	7M1012-XXXX o/or 7M1012BO-XXXX	<b>L. 119 cm</b>																																																	
B	7M2260-RGA o/or 7M2260-RBO																																																		
o/or																																																			
A	7M1008-XXXX o/or 7M1008BO-XXXX	<b>L. 75 cm</b>																																																	
B	7M2860-RGA o/or 7M2860-RBO																																																		

Struttura in acciaio verniciato con polveri epossidiche con basi in acciaio verniciato con polveri epossidiche con ruote in tecnopolimero (2 con freno e 2 senza) per il montaggio di **2 o 4** pannelli Mitesco.

Structure in powder-coated steel with powder-coated steel bases with high-tech polymer castors (2 with and 2 without brakes), to mount **2 or 4** Mitesco panels.

Structure en acier peint époxy avec bases en acier peint époxy et roulettes en technopolymère (2 avec freins et 2 sans) pour le montage de **2 ou 4** panneaux Mitesco.

Estructura de acero recubierto epoxi con bases de acero recubierto epoxi con ruedasde polimero (2 con freno y 2 sin) para el montaje de **2 o 4** paneles Mitesco.

Standssäulen aus pulverbeschichtetem Stahl mit Standfuß aus pulverbeschichtetem Stahl mit Rollen aus Technopolymer (2 davon feststellbar) zur Aufstellung von **2 oder 4** Mitesco-Paneeelen.

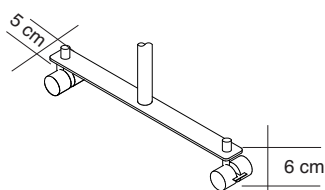

Dettaglio della base  
Detail of the base  
Détail de la base  
Detaille de la base  
Details der Basis

# MITESCO DIVIDER

design Michele De Lucchi  
Snowsound® technology by Caimi Brevetti

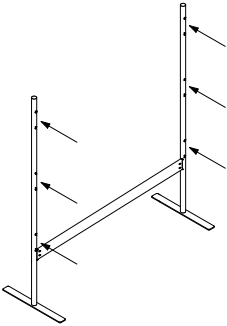
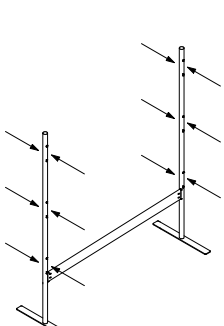
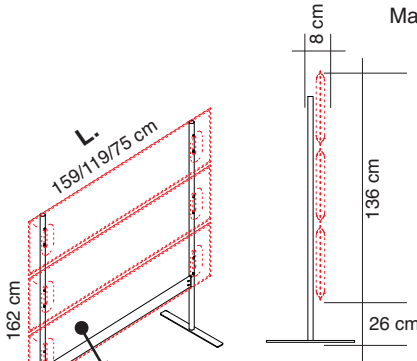
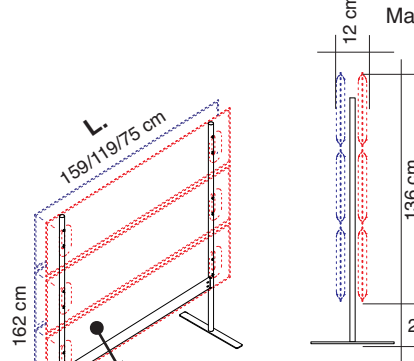
	Codice Code	Colore Colour	Prezzo Price		Codice Code	Colore Colour	Prezzo Price
<b>STRUTTURA MONOFRONTALE</b> <b>ONE-SIDED FRAME</b> 	<b>7M3650-GA</b>	Grigio argento Silver grey Gris argenté Gris plata Silbergrau	Per pannelli For panels <b>L. 159 cm</b>	<b>STRUTTURA BIFRONTALE</b> <b>DOUBLE-SIDED FRAME</b> 	<b>7M6650-GA</b>	Grigio argento Silver grey Gris argenté Gris plata Silbergrau	Per pannelli For panels <b>L. 159 cm</b>
	<b>7M3650-BO</b>	Bianco opaco Mat white Blanc mat Blanco mate Mattweiß	Per pannelli For panels <b>L. 159 cm</b>		<b>7M6650-BO</b>	Bianco opaco Mat white Blanc mat Blanco mate Mattweiß	Per pannelli For panels <b>L. 159 cm</b>
	<b>7M3250-GA</b>	Grigio argento Silver grey Gris argenté Gris plata Silbergrau	Per pannelli For panels <b>L. 119 cm</b>		<b>7M6250-GA</b>	Grigio argento Silver grey Gris argenté Gris plata Silbergrau	Per pannelli For panels <b>L. 119 cm</b>
	<b>7M3250-BO</b>	Bianco opaco Mat white Blanc mat Blanco mate Mattweiß	Per pannelli For panels <b>L. 119 cm</b>		<b>7M6250-BO</b>	Bianco opaco Mat white Blanc mat Blanco mate Mattweiß	Per pannelli For panels <b>L. 119 cm</b>
	<b>7M3850-GA</b>	Grigio argento Silver grey Gris argenté Gris plata Silbergrau	Per pannelli For panels <b>L. 75 cm</b>		<b>7M6850-GA</b>	Grigio argento Silver grey Gris argenté Gris plata Silbergrau	Per pannelli For panels <b>L. 75 cm</b>
	<b>7M3850-BO</b>	Bianco opaco Mat white Blanc mat Blanco mate Mattweiß	Per pannelli For panels <b>L. 75 cm</b>		<b>7M6850-BO</b>	Bianco opaco Mat white Blanc mat Blanco mate Mattweiß	Per pannelli For panels <b>L. 75 cm</b>
		<b>A</b> 7M1016-XXXX o/or 7M1016BO-XXXX <b>B</b> 7M3650-GA o/or 7M3650-BO	<b>L. 159 cm</b>			<b>A</b> 7M1016-XXXX o/or 7M1016BO-XXXX <b>B</b> 7M6650-GA o/or 7M6650-BO	<b>L. 159 cm</b>
	<b>A</b> 7M1012-XXXX o/or 7M1012BO-XXXX <b>B</b> 7M3250-GA o/or 7M3250-BO	<b>L. 119 cm</b>	<b>A</b> 7M1012-XXXX o/or 7M1012BO-XXXX <b>B</b> 7M6250-GA o/or 7M6250-BO		<b>L. 119 cm</b>		
	<b>A</b> 7M1008-XXXX o/or 7M1008BO-XXXX <b>B</b> 7M3850-GA o/or 7M3850-BO	<b>L. 75 cm</b>	<b>A</b> 7M1008-XXXX o/or 7M1008BO-XXXX <b>B</b> 7M6850-GA o/or 7M6850-BO		<b>L. 75 cm</b>		

Struttura in acciaio verniciato con polveri epossidiche con basi in acciaio verniciato con polveri epossidiche per il montaggio di 3 o 6 pannelli Mitesco.

Structure in powder-coated steel with bases in powder-coated steel to mount 3 or 6 Mitesco panels.

Structure en acier peint époxy avec bases en acier peint époxy pour le montage de 3 ou 6 panneaux Mitesco.

Estructura de acero recubierto epoxi con bases de acero recubierto epoxi para el montaje de 3 o 6 paneles Mitesco.

Standssäulen aus pulverbeschichtetem Stahl mit Standfuß aus pulverbeschichtetem Stahl zur Aufstellung von 3 oder 6 Mitesco-Paneele.

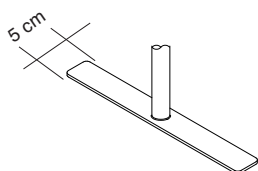

Dettaglio della base  
Detail of the base  
Détail de la base  
Detalle de la base  
Details der Basis

# MITESCO DIVIDER

design Michele De Lucchi  
Snowsound® technology by Caimi Brevetti

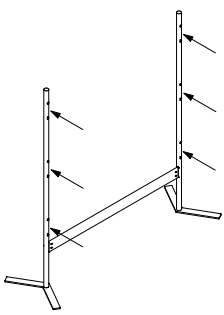
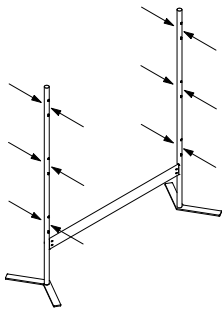
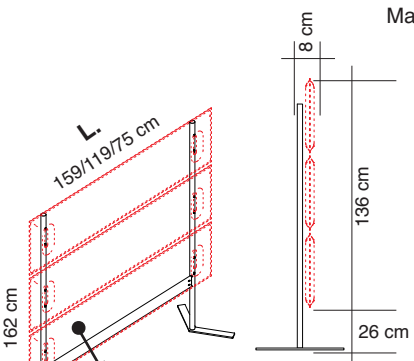
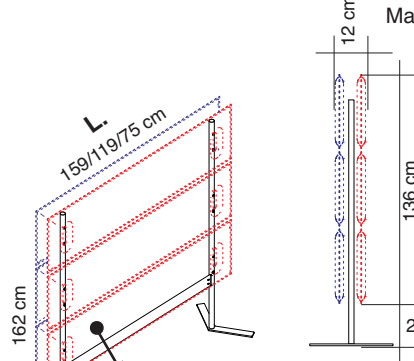
	Codice Code	Colore Colour	Prezzo Price		Codice Code	Colore Colour	Prezzo Price										
<b>STRUTTURA MONOFRONTA</b>  <b>ONE-SIDED FRAME</b>  	<b>7M3630-GA</b>	Grigio argento Silver grey Gris argenté Gris plata Silbergrau	Per pannelli For panels <b>L. 159 cm</b>	<b>STRUTTURA BIFRONTA</b>  <b>DOUBLE-SIDED FRAME</b>  	<b>7M6630-GA</b>	Grigio argento Silver grey Gris argenté Gris plata Silbergrau	Per pannelli For panels <b>L. 159 cm</b>										
	<b>7M3630-BO</b>	Bianco opaco Mat white Blanc mat Blanco mate Mattweiß	Per pannelli For panels <b>L. 159 cm</b>		<b>7M6630-BO</b>	Bianco opaco Mat white Blanc mat Blanco mate Mattweiß	Per pannelli For panels <b>L. 159 cm</b>										
	<b>7M3230-GA</b>	Grigio argento Silver grey Gris argenté Gris plata Silbergrau	Per pannelli For panels <b>L. 119 cm</b>		<b>7M6230-GA</b>	Grigio argento Silver grey Gris argenté Gris plata Silbergrau	Per pannelli For panels <b>L. 119 cm</b>										
	<b>7M3230-BO</b>	Bianco opaco Mat white Blanc mat Blanco mate Mattweiß	Per pannelli For panels <b>L. 119 cm</b>		<b>7M6230-BO</b>	Bianco opaco Mat white Blanc mat Blanco mate Mattweiß	Per pannelli For panels <b>L. 119 cm</b>										
	<b>7M3830-GA</b>	Grigio argento Silver grey Gris argenté Gris plata Silbergrau	Per pannelli For panels <b>L. 75 cm</b>		<b>7M6830-GA</b>	Grigio argento Silver grey Gris argenté Gris plata Silbergrau	Per pannelli For panels <b>L. 75 cm</b>										
	<b>7M3830-BO</b>	Bianco opaco Mat white Blanc mat Blanco mate Mattweiß	Per pannelli For panels <b>L. 75 cm</b>		<b>7M6830-BO</b>	Bianco opaco Mat white Blanc mat Blanco mate Mattweiß	Per pannelli For panels <b>L. 75 cm</b>										
		<table border="1"> <tr> <td>A</td> <td>7M1016-XXXX o/or 7M1016BO-XXXX</td> <td rowspan="2"><b>L. 159 cm</b></td> </tr> <tr> <td>B</td> <td>7M3630-GA o/or 7M3630-BO</td> </tr> </table>			A	7M1016-XXXX o/or 7M1016BO-XXXX	<b>L. 159 cm</b>	B	7M3630-GA o/or 7M3630-BO		<table border="1"> <tr> <td>A</td> <td>7M1016-XXXX o/or 7M1016BO-XXXX</td> <td rowspan="2"><b>L. 159 cm</b></td> </tr> <tr> <td>B</td> <td>7M6630-GA o/or 7M6630-BO</td> </tr> </table>		A	7M1016-XXXX o/or 7M1016BO-XXXX	<b>L. 159 cm</b>	B	7M6630-GA o/or 7M6630-BO
	A	7M1016-XXXX o/or 7M1016BO-XXXX	<b>L. 159 cm</b>														
	B	7M3630-GA o/or 7M3630-BO															
	A	7M1016-XXXX o/or 7M1016BO-XXXX	<b>L. 159 cm</b>														
B	7M6630-GA o/or 7M6630-BO																
	<table border="1"> <tr> <td>A</td> <td>7M1012-XXXX o/or 7M1012BO-XXXX</td> <td rowspan="2"><b>L. 119 cm</b></td> </tr> <tr> <td>B</td> <td>7M3230-GA o/or 7M3230-BO</td> </tr> </table>		A	7M1012-XXXX o/or 7M1012BO-XXXX	<b>L. 119 cm</b>	B	7M3230-GA o/or 7M3230-BO	<table border="1"> <tr> <td>A</td> <td>7M1012-XXXX o/or 7M1012BO-XXXX</td> <td rowspan="2"><b>L. 119 cm</b></td> </tr> <tr> <td>B</td> <td>7M6230-GA o/or 7M6230-BO</td> </tr> </table>		A	7M1012-XXXX o/or 7M1012BO-XXXX	<b>L. 119 cm</b>	B	7M6230-GA o/or 7M6230-BO			
A	7M1012-XXXX o/or 7M1012BO-XXXX	<b>L. 119 cm</b>															
B	7M3230-GA o/or 7M3230-BO																
A	7M1012-XXXX o/or 7M1012BO-XXXX	<b>L. 119 cm</b>															
B	7M6230-GA o/or 7M6230-BO																
	<table border="1"> <tr> <td>A</td> <td>7M1008-XXXX o/or 7M1008BO-XXXX</td> <td rowspan="2"><b>L. 75 cm</b></td> </tr> <tr> <td>B</td> <td>7M3830-GA o/or 7M3830-BO</td> </tr> </table>		A	7M1008-XXXX o/or 7M1008BO-XXXX	<b>L. 75 cm</b>	B	7M3830-GA o/or 7M3830-BO	<table border="1"> <tr> <td>A</td> <td>7M1008-XXXX o/or 7M1008BO-XXXX</td> <td rowspan="2"><b>L. 75 cm</b></td> </tr> <tr> <td>B</td> <td>7M6830-GA o/or 7M6830-BO</td> </tr> </table>		A	7M1008-XXXX o/or 7M1008BO-XXXX	<b>L. 75 cm</b>	B	7M6830-GA o/or 7M6830-BO			
A	7M1008-XXXX o/or 7M1008BO-XXXX	<b>L. 75 cm</b>															
B	7M3830-GA o/or 7M3830-BO																
A	7M1008-XXXX o/or 7M1008BO-XXXX	<b>L. 75 cm</b>															
B	7M6830-GA o/or 7M6830-BO																

Struttura in acciaio verniciato con polveri epossidiche con basi in acciaio verniciato con polveri epossidiche per il montaggio di **3 o 6** pannelli Mitesco.

Structure in powder-coated steel with bases in powder-coated steel to mount **3 or 6** Mitesco panels.

Structure en acier peint époxy avec bases en acier peint époxy pour le montage de **3 ou 6** panneaux Mitesco.

Estructura de acero recubierto epoxi con bases de acero recubierto epoxi para el montaje de **3 o 6** paneles Mitesco.

Standssäulen aus pulverbeschichtetem Stahl mit Standfuß aus pulverbeschichtetem Stahl zur Aufstellung von **3 oder 6** Mitesco-Paneeelen.

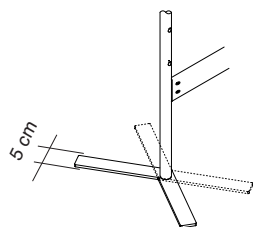

Dettaglio della base. La base può essere montata in due posizioni, interna o esterna.  
Detail of the base. The base can be mounted in two positions, internal or external.

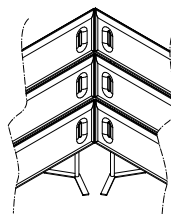

Nelle composizioni ad angolo, l'utilizzo di questa base permette il perfetto accostamento dei pannelli.  
In the corner compositions the use of this base allows the perfect approaching of the panels.



# MITESCO DIVIDER

design Michele De Lucchi  
Snowsound® technology by Caimi Brevetti

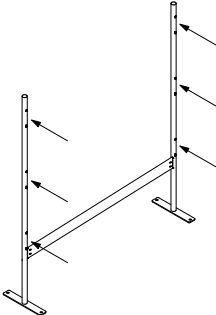
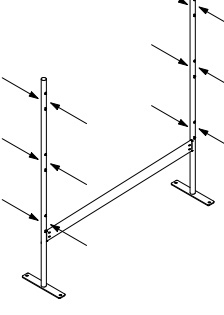
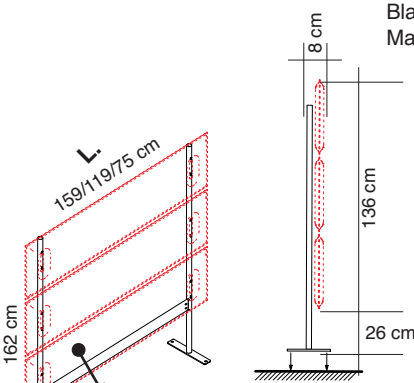
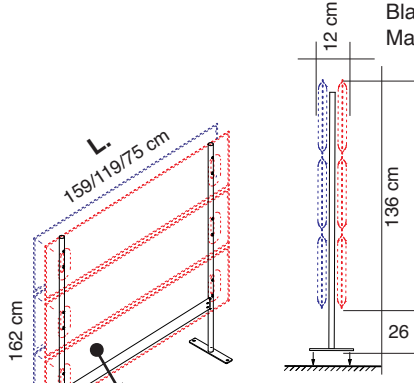
	Codice Code	Colore Colour	Prezzo Price		Codice Code	Colore Colour	Prezzo Price								
<b>STRUTTURA MONOFRONTALE</b>  <b>ONE-SIDED FRAME</b>  	<b>7M3625-GA</b>	Grigio argento Silver grey Gris argenté Gris plata Silbergrau	Per pannelli For panels <b>L. 159 cm</b>	<b>STRUTTURA BIFRONTALE</b>  <b>DOUBLE-SIDED FRAME</b>  	<b>7M6625-GA</b>	Grigio argento Silver grey Gris argenté Gris plata Silbergrau	Per pannelli For panels <b>L. 159 cm</b>								
	<b>7M3625-BO</b>	Bianco opaco Mat white Blanc mat Blanco mate Mattweiß	Per pannelli For panels <b>L. 159 cm</b>		<b>7M6625-BO</b>	Bianco opaco Mat white Blanc mat Blanco mate Mattweiß	Per pannelli For panels <b>L. 159 cm</b>								
	<b>7M3225-GA</b>	Grigio argento Silver grey Gris argenté Gris plata Silbergrau	Per pannelli For panels <b>L. 119 cm</b>		<b>7M6225-GA</b>	Grigio argento Silver grey Gris argenté Gris plata Silbergrau	Per pannelli For panels <b>L. 119 cm</b>								
	<b>7M3225-BO</b>	Bianco opaco Mat white Blanc mat Blanco mate Mattweiß	Per pannelli For panels <b>L. 119 cm</b>		<b>7M6225-BO</b>	Bianco opaco Mat white Blanc mat Blanco mate Mattweiß	Per pannelli For panels <b>L. 119 cm</b>								
	<b>7M3825-GA</b>	Grigio argento Silver grey Gris argenté Gris plata Silbergrau	Per pannelli For panels <b>L. 75 cm</b>		<b>7M6825-GA</b>	Grigio argento Silver grey Gris argenté Gris plata Silbergrau	Per pannelli For panels <b>L. 75 cm</b>								
	<b>7M3825-BO</b>	Bianco opaco Mat white Blanc mat Blanco mate Mattweiß	Per pannelli For panels <b>L. 75 cm</b>		<b>7M6825-BO</b>	Bianco opaco Mat white Blanc mat Blanco mate Mattweiß	Per pannelli For panels <b>L. 75 cm</b>								
															
	<table border="1"> <tr> <td><b>A</b></td> <td>7M1016-XXXX o/or 7M1016BO-XXXX</td> <td rowspan="2"><b>L. 159 cm</b></td> </tr> <tr> <td><b>B</b></td> <td>7M3625-GA o/or 7M3625-BO</td> </tr> </table>		<b>A</b>		7M1016-XXXX o/or 7M1016BO-XXXX	<b>L. 159 cm</b>	<b>B</b>	7M3625-GA o/or 7M3625-BO	<table border="1"> <tr> <td><b>A</b></td> <td>7M1016-XXXX o/or 7M1016BO-XXXX</td> <td rowspan="2"><b>L. 159 cm</b></td> </tr> <tr> <td><b>B</b></td> <td>7M6625-GA o/or 7M6625-BO</td> </tr> </table>		<b>A</b>	7M1016-XXXX o/or 7M1016BO-XXXX	<b>L. 159 cm</b>	<b>B</b>	7M6625-GA o/or 7M6625-BO
	<b>A</b>	7M1016-XXXX o/or 7M1016BO-XXXX	<b>L. 159 cm</b>												
	<b>B</b>	7M3625-GA o/or 7M3625-BO													
<b>A</b>	7M1016-XXXX o/or 7M1016BO-XXXX	<b>L. 159 cm</b>													
<b>B</b>	7M6625-GA o/or 7M6625-BO														
<table border="1"> <tr> <td><b>A</b></td> <td>7M1012-XXXX o/or 7M1012BO-XXXX</td> <td rowspan="2"><b>L. 119 cm</b></td> </tr> <tr> <td><b>B</b></td> <td>7M3225-GA o/or 7M3225-BO</td> </tr> </table>		<b>A</b>	7M1012-XXXX o/or 7M1012BO-XXXX	<b>L. 119 cm</b>	<b>B</b>	7M3225-GA o/or 7M3225-BO	<table border="1"> <tr> <td><b>A</b></td> <td>7M1012-XXXX o/or 7M1012BO-XXXX</td> <td rowspan="2"><b>L. 119 cm</b></td> </tr> <tr> <td><b>B</b></td> <td>7M6225-GA o/or 7M6225-BO</td> </tr> </table>		<b>A</b>	7M1012-XXXX o/or 7M1012BO-XXXX	<b>L. 119 cm</b>	<b>B</b>	7M6225-GA o/or 7M6225-BO		
<b>A</b>	7M1012-XXXX o/or 7M1012BO-XXXX	<b>L. 119 cm</b>													
<b>B</b>	7M3225-GA o/or 7M3225-BO														
<b>A</b>	7M1012-XXXX o/or 7M1012BO-XXXX	<b>L. 119 cm</b>													
<b>B</b>	7M6225-GA o/or 7M6225-BO														
<table border="1"> <tr> <td><b>A</b></td> <td>7M1008-XXXX o/or 7M1008BO-XXXX</td> <td rowspan="2"><b>L. 75 cm</b></td> </tr> <tr> <td><b>B</b></td> <td>7M3825-GA o/or 7M3825-BO</td> </tr> </table>		<b>A</b>	7M1008-XXXX o/or 7M1008BO-XXXX	<b>L. 75 cm</b>	<b>B</b>	7M3825-GA o/or 7M3825-BO	<table border="1"> <tr> <td><b>A</b></td> <td>7M1008-XXXX o/or 7M1008BO-XXXX</td> <td rowspan="2"><b>L. 75 cm</b></td> </tr> <tr> <td><b>B</b></td> <td>7M6825-GA o/or 7M6825-BO</td> </tr> </table>		<b>A</b>	7M1008-XXXX o/or 7M1008BO-XXXX	<b>L. 75 cm</b>	<b>B</b>	7M6825-GA o/or 7M6825-BO		
<b>A</b>	7M1008-XXXX o/or 7M1008BO-XXXX	<b>L. 75 cm</b>													
<b>B</b>	7M3825-GA o/or 7M3825-BO														
<b>A</b>	7M1008-XXXX o/or 7M1008BO-XXXX	<b>L. 75 cm</b>													
<b>B</b>	7M6825-GA o/or 7M6825-BO														

Struttura in acciaio verniciato con polveri epossidiche con basi in acciaio verniciato con polveri epossidiche per fissaggio a terra (viti non incluse) per il montaggio di **3 o 6** pannelli Mitesco.

Structure in powder-coated steel with powder-coated steel bases for floor fixing (screws not included), to mount **3 or 6** Mitesco panels.

Structure en acier peint époxy avec bases en acier peint époxy pour fixation au sol (vis pas incluses) pour le montage de **3 ou 6** panneaux Mitesco.

Estructura de acero recubierto epoxi con bases de acero recubierto epoxi para fijación al suelo (tornillos no incluidos) para el montaje de **3 o 6** paneles Mitesco.

Standsäulen aus pulverbeschichtetem Stahl mit Fuß zur Bodenbefestigung (Schrauben nicht inkludiert) aus pulverbeschichtetem Stahl zur Aufstellung von **3 oder 6** Mitesco-Paneele.

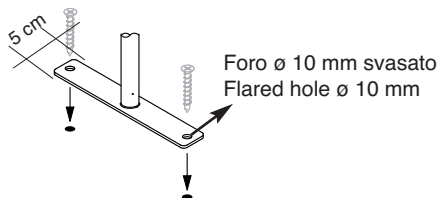

Foro ø 10 mm svasato  
Flared hole ø 10 mm

Dettaglio della base (viti non incluse)  
Detail of the base (screws not included)  
Détail de la base (vis pas incluses)  
Detalle de la base (tornillos no incluidos)  
Details der Basis (Schrauben nicht inkludiert)



# MITESCO DIVIDER

design Michele De Lucchi  
Snowsound® technology by Caimi Brevetti

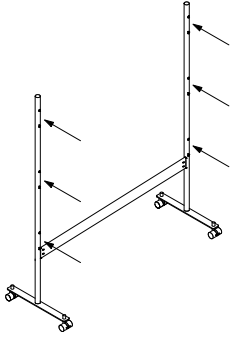
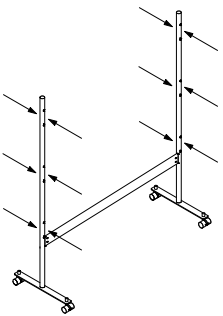
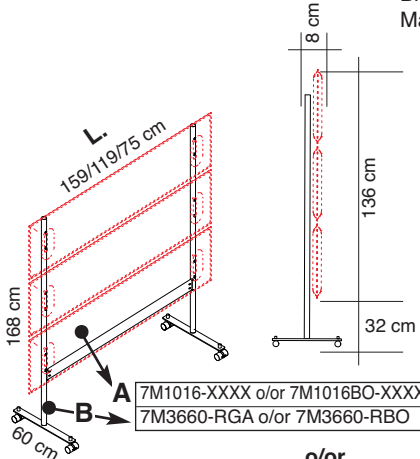
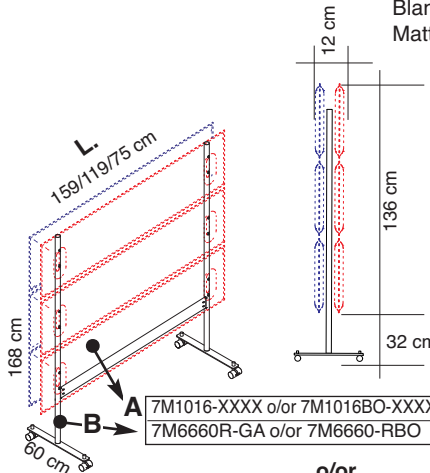
	Codice Code	Colore Colour	Prezzo Price		Codice Code	Colore Colour	Prezzo Price																																												
<b>STRUTTURA MONOFRONTALE</b> <b>ONE-SIDED FRAME</b> 	<b>7M3660-RGA</b>	Grigio argento Silver grey Gris argenté Gris plata Silbergrau	Per pannelli For panels <b>L. 159 cm</b>	<b>STRUTTURA BIFRONTALE</b> <b>DOUBLE-SIDED FRAME</b> 	<b>7M6660-RGA</b>	Grigio argento Silver grey Gris argenté Gris plata Silbergrau	Per pannelli For panels <b>L. 159 cm</b>																																												
	<b>7M3660-RBO</b>	Bianco opaco Mat white Blanc mat Blanco mate Mattweiß	Per pannelli For panels <b>L. 159 cm</b>		<b>7M6660-RBO</b>	Bianco opaco Mat white Blanc mat Blanco mate Mattweiß	Per pannelli For panels <b>L. 159 cm</b>																																												
	<b>7M3260-RGA</b>	Grigio argento Silver grey Gris argenté Gris plata Silbergrau	Per pannelli For panels <b>L. 119 cm</b>		<b>7M6260-RGA</b>	Grigio argento Silver grey Gris argenté Gris plata Silbergrau	Per pannelli For panels <b>L. 119 cm</b>																																												
	<b>7M3260-RBO</b>	Bianco opaco Mat white Blanc mat Blanco mate Mattweiß	Per pannelli For panels <b>L. 119 cm</b>		<b>7M6260-RBO</b>	Bianco opaco Mat white Blanc mat Blanco mate Mattweiß	Per pannelli For panels <b>L. 119 cm</b>																																												
	<b>7M3860-RGA</b>	Grigio argento Silver grey Gris argenté Gris plata Silbergrau	Per pannelli For panels <b>L. 75 cm</b>		<b>7M6860-RGA</b>	Grigio argento Silver grey Gris argenté Gris plata Silbergrau	Per pannelli For panels <b>L. 75 cm</b>																																												
	<b>7M3860-RBO</b>	Bianco opaco Mat white Blanc mat Blanco mate Mattweiß	Per pannelli For panels <b>L. 75 cm</b>		<b>7M6860-RBO</b>	Bianco opaco Mat white Blanc mat Blanco mate Mattweiß	Per pannelli For panels <b>L. 75 cm</b>																																												
			<table border="1"> <tr> <td>A</td> <td>7M1016-XXXX o/or 7M1016BO-XXXX</td> <td rowspan="2"><b>L. 159 cm</b></td> </tr> <tr> <td>B</td> <td>7M3660-RGA o/or 7M3660-RBO</td> </tr> <tr> <td colspan="3" style="text-align: center;">o/or</td> </tr> <tr> <td>A</td> <td>7M1012-XXXX o/or 7M1012BO-XXXX</td> <td rowspan="2"><b>L. 119 cm</b></td> </tr> <tr> <td>B</td> <td>7M3260-RGA o/or 7M3260-RBO</td> </tr> <tr> <td colspan="3" style="text-align: center;">o/or</td> </tr> <tr> <td>A</td> <td>7M1008-XXXX o/or 7M1008BO-XXXX</td> <td rowspan="2"><b>L. 75 cm</b></td> </tr> <tr> <td>B</td> <td>7M3860-RGA o/or 7M3860-RBO</td> </tr> </table>		A	7M1016-XXXX o/or 7M1016BO-XXXX	<b>L. 159 cm</b>	B	7M3660-RGA o/or 7M3660-RBO	o/or			A	7M1012-XXXX o/or 7M1012BO-XXXX	<b>L. 119 cm</b>	B	7M3260-RGA o/or 7M3260-RBO	o/or			A	7M1008-XXXX o/or 7M1008BO-XXXX	<b>L. 75 cm</b>	B	7M3860-RGA o/or 7M3860-RBO			<table border="1"> <tr> <td>A</td> <td>7M1016-XXXX o/or 7M1016BO-XXXX</td> <td rowspan="2"><b>L. 159 cm</b></td> </tr> <tr> <td>B</td> <td>7M6660R-GA o/or 7M6660-RBO</td> </tr> <tr> <td colspan="3" style="text-align: center;">o/or</td> </tr> <tr> <td>A</td> <td>7M1012-XXXX o/or 7M1012BO-XXXX</td> <td rowspan="2"><b>L. 119 cm</b></td> </tr> <tr> <td>B</td> <td>7M6260-RGA o/or 7M6260-RBO</td> </tr> <tr> <td colspan="3" style="text-align: center;">o/or</td> </tr> <tr> <td>A</td> <td>7M1008-XXXX o/or 7M1008BO-XXXX</td> <td rowspan="2"><b>L. 75 cm</b></td> </tr> <tr> <td>B</td> <td>7M6860-RGA o/or 7M6860-RBO</td> </tr> </table>		A	7M1016-XXXX o/or 7M1016BO-XXXX	<b>L. 159 cm</b>	B	7M6660R-GA o/or 7M6660-RBO	o/or			A	7M1012-XXXX o/or 7M1012BO-XXXX	<b>L. 119 cm</b>	B	7M6260-RGA o/or 7M6260-RBO	o/or			A	7M1008-XXXX o/or 7M1008BO-XXXX	<b>L. 75 cm</b>	B	7M6860-RGA o/or 7M6860-RBO	
	A	7M1016-XXXX o/or 7M1016BO-XXXX	<b>L. 159 cm</b>																																																
	B	7M3660-RGA o/or 7M3660-RBO																																																	
	o/or																																																		
A	7M1012-XXXX o/or 7M1012BO-XXXX	<b>L. 119 cm</b>																																																	
B	7M3260-RGA o/or 7M3260-RBO																																																		
o/or																																																			
A	7M1008-XXXX o/or 7M1008BO-XXXX	<b>L. 75 cm</b>																																																	
B	7M3860-RGA o/or 7M3860-RBO																																																		
A	7M1016-XXXX o/or 7M1016BO-XXXX	<b>L. 159 cm</b>																																																	
B	7M6660R-GA o/or 7M6660-RBO																																																		
o/or																																																			
A	7M1012-XXXX o/or 7M1012BO-XXXX	<b>L. 119 cm</b>																																																	
B	7M6260-RGA o/or 7M6260-RBO																																																		
o/or																																																			
A	7M1008-XXXX o/or 7M1008BO-XXXX	<b>L. 75 cm</b>																																																	
B	7M6860-RGA o/or 7M6860-RBO																																																		

Struttura in acciaio verniciato con polveri epossidiche con basi in acciaio verniciato con polveri epossidiche con ruote in tecnopolimero (2 con freno e 2 senza) per il montaggio di 3 o 6 pannelli Mitesco.

Structure in powder-coated steel with powder-coated steel bases with high-tech polymer castors (2 with and 2 without brakes), to mount 3 or 6 Mitesco panels.

Structure en acier peint époxy avec bases en acier peint époxy et roulettes en technopolymère (2 avec freins et 2 sans) pour le montage de 3 ou 6 panneaux Mitesco.

Estructura de acero recubierto epoxi con bases de acero recubierto epoxi con ruedas en polimero (2 con freno y 2 sin) para el montaje de 3 o 6 paneles Mitesco.

Standssäulen aus pulverbeschichtetem Stahl mit Standfuß aus pulverbeschichtetem Stahl mit Rollen aus Technopolymer (2 davon feststellbar) zur Aufstellung von 3 oder 6 Mitesco-Paneeelen.

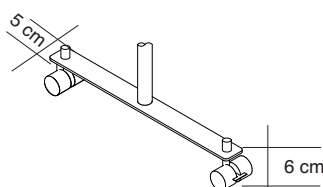

Dettaglio della base  
Detail of the base  
Détail de la base  
Detaille de la base  
Details der Basis

# MITESCO DIVIDER

design Michele De Lucchi  
Snowsound® technology by Caimi Brevetti

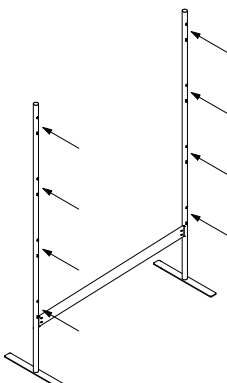
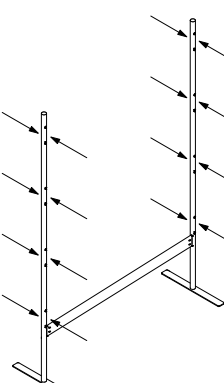
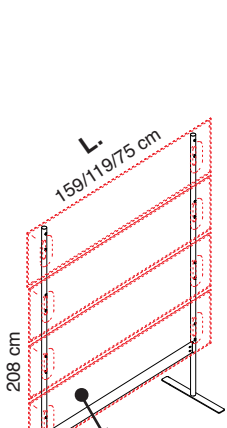
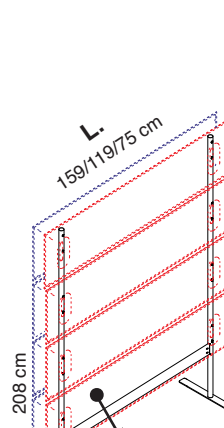
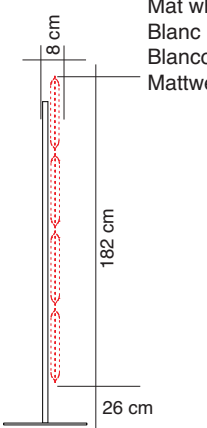
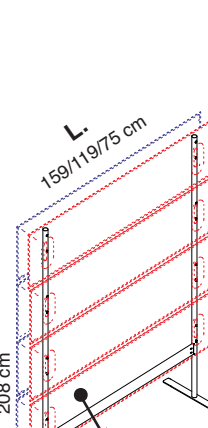
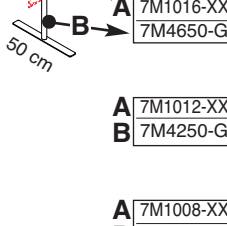
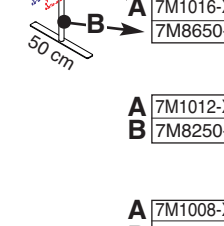
	Codice Code	Colore Colour	Prezzo Price		Codice Code	Colore Colour	Prezzo Price										
<b>STRUTTURA MONOFRONTA</b>  <b>ONE-SIDED FRAME</b>  	<b>7M4650-GA</b>	Grigio argento Silver grey Gris argenté Gris plata Silbergrau	Per pannelli For panels <b>L. 159 cm</b>	<b>STRUTTURA BIFRONTA</b>  <b>DOUBLE-SIDED FRAME</b>  	<b>7M8650-GA</b>	Grigio argento Silver grey Gris argenté Gris plata Silbergrau	Per pannelli For panels <b>L. 159 cm</b>										
	<b>7M4650-BO</b>	Bianco opaco Mat white Blanc mat Blanco mate Mattweiß	Per pannelli For panels <b>L. 159 cm</b>		<b>7M8650-BO</b>	Bianco opaco Mat white Blanc mat Blanco mate Mattweiß	Per pannelli For panels <b>L. 159 cm</b>										
	<b>7M4250-GA</b>	Grigio argento Silver grey Gris argenté Gris plata Silbergrau	Per pannelli For panels <b>L. 119 cm</b>		<b>7M8250-GA</b>	Grigio argento Silver grey Gris argenté Gris plata Silbergrau	Per pannelli For panels <b>L. 119 cm</b>										
	<b>7M4250-BO</b>	Bianco opaco Mat white Blanc mat Blanco mate Mattweiß	Per pannelli For panels <b>L. 119 cm</b>		<b>7M8250-BO</b>	Bianco opaco Mat white Blanc mat Blanco mate Mattweiß	Per pannelli For panels <b>L. 119 cm</b>										
	<b>7M4850-GA</b>	Grigio argento Silver grey Gris argenté Gris plata Silbergrau	Per pannelli For panels <b>L. 75 cm</b>		<b>7M8850-GA</b>	Grigio argento Silver grey Gris argenté Gris plata Silbergrau	Per pannelli For panels <b>L. 75 cm</b>										
	<b>7M4850-BO</b>	Bianco opaco Mat white Blanc mat Blanco mate Mattweiß	Per pannelli For panels <b>L. 75 cm</b>		<b>7M8850-BO</b>	Bianco opaco Mat white Blanc mat Blanco mate Mattweiß	Per pannelli For panels <b>L. 75 cm</b>										
		<table border="1"> <tr> <td><b>A</b></td> <td>7M1016-XXXX o/or 7M1016BO-XXXX</td> <td rowspan="2"><b>L. 159 cm</b></td> </tr> <tr> <td><b>B</b></td> <td>7M4650-GA o/or 7M4650-BO</td> </tr> </table>			<b>A</b>	7M1016-XXXX o/or 7M1016BO-XXXX	<b>L. 159 cm</b>	<b>B</b>	7M4650-GA o/or 7M4650-BO		<table border="1"> <tr> <td><b>A</b></td> <td>7M1016-XXXX o/or 7M1016BO-XXXX</td> <td rowspan="2"><b>L. 159 cm</b></td> </tr> <tr> <td><b>B</b></td> <td>7M8650-GA o/or 7M8650-BO</td> </tr> </table>		<b>A</b>	7M1016-XXXX o/or 7M1016BO-XXXX	<b>L. 159 cm</b>	<b>B</b>	7M8650-GA o/or 7M8650-BO
	<b>A</b>	7M1016-XXXX o/or 7M1016BO-XXXX	<b>L. 159 cm</b>														
	<b>B</b>	7M4650-GA o/or 7M4650-BO															
	<b>A</b>	7M1016-XXXX o/or 7M1016BO-XXXX	<b>L. 159 cm</b>														
<b>B</b>	7M8650-GA o/or 7M8650-BO																
	<table border="1"> <tr> <td><b>A</b></td> <td>7M1012-XXXX o/or 7M1012BO-XXXX</td> <td rowspan="2"><b>L. 119 cm</b></td> </tr> <tr> <td><b>B</b></td> <td>7M4250-GA o/or 7M4250-BO</td> </tr> </table>		<b>A</b>	7M1012-XXXX o/or 7M1012BO-XXXX	<b>L. 119 cm</b>	<b>B</b>	7M4250-GA o/or 7M4250-BO		<table border="1"> <tr> <td><b>A</b></td> <td>7M1012-XXXX o/or 7M1012BO-XXXX</td> <td rowspan="2"><b>L. 119 cm</b></td> </tr> <tr> <td><b>B</b></td> <td>7M8250-GA o/or 7M8250-BO</td> </tr> </table>		<b>A</b>	7M1012-XXXX o/or 7M1012BO-XXXX	<b>L. 119 cm</b>	<b>B</b>	7M8250-GA o/or 7M8250-BO		
<b>A</b>	7M1012-XXXX o/or 7M1012BO-XXXX	<b>L. 119 cm</b>															
<b>B</b>	7M4250-GA o/or 7M4250-BO																
<b>A</b>	7M1012-XXXX o/or 7M1012BO-XXXX	<b>L. 119 cm</b>															
<b>B</b>	7M8250-GA o/or 7M8250-BO																
	<table border="1"> <tr> <td><b>A</b></td> <td>7M1008-XXXX o/or 7M1008BO-XXXX</td> <td rowspan="2"><b>L. 75 cm</b></td> </tr> <tr> <td><b>B</b></td> <td>7M4850-GA o/or 7M4850-BO</td> </tr> </table>		<b>A</b>	7M1008-XXXX o/or 7M1008BO-XXXX	<b>L. 75 cm</b>	<b>B</b>	7M4850-GA o/or 7M4850-BO		<table border="1"> <tr> <td><b>A</b></td> <td>7M1008-XXXX o/or 7M1008BO-XXXX</td> <td rowspan="2"><b>L. 75 cm</b></td> </tr> <tr> <td><b>B</b></td> <td>7M8850-GA o/or 7M8850-BO</td> </tr> </table>		<b>A</b>	7M1008-XXXX o/or 7M1008BO-XXXX	<b>L. 75 cm</b>	<b>B</b>	7M8850-GA o/or 7M8850-BO		
<b>A</b>	7M1008-XXXX o/or 7M1008BO-XXXX	<b>L. 75 cm</b>															
<b>B</b>	7M4850-GA o/or 7M4850-BO																
<b>A</b>	7M1008-XXXX o/or 7M1008BO-XXXX	<b>L. 75 cm</b>															
<b>B</b>	7M8850-GA o/or 7M8850-BO																

Struttura in acciaio verniciato con polveri epossidiche con basi in acciaio verniciato con polveri epossidiche per il montaggio di 4 o 8 pannelli Mitesco.

Structure in powder-coated steel with bases in powder-coated steel to mount 4 ou 8 Mitesco panels.

Structure en acier peint époxy avec bases en acier peint époxy pour le montage de 4 ou 8 panneaux Mitesco.

Estructura de acero recubierto epoxi con bases de acero recubierto epoxi para el montaje de 4 o 8 paneles Mitesco.

Standssäulen aus pulverbeschichtetem Stahl mit Standfuß aus pulverbeschichtetem Stahl zur Aufstellung von 4 oder 8 Mitesco-Paneele.

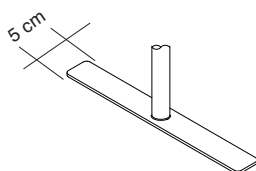

Dettaglio della base  
Detail of the base  
Détail de la base  
Detalle de la base  
Details der Basis

# MITESCO DIVIDER

design Michele De Lucchi  
Snowsound® technology by Caimi Brevetti

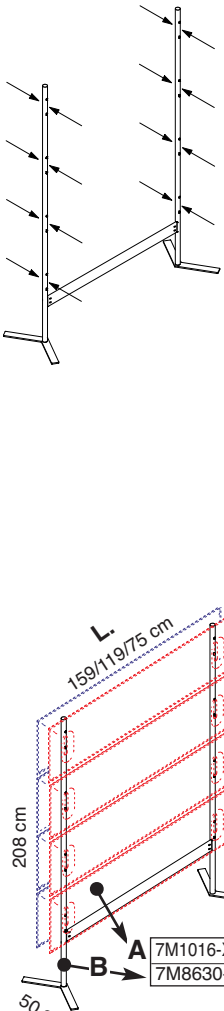
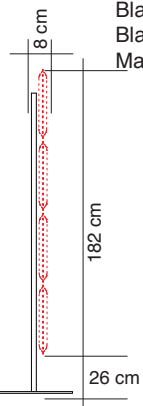
	Codice Code	Colore Colour	Prezzo Price		Codice Code	Colore Colour	Prezzo Price									
<b>STRUTTURA MONOFRONTA</b>  <b>ONE-SIDED FRAME</b>  	<b>7M4630-GA</b>	Grigio argento Silver grey Gris argenté Gris plata Silbergrau	Per pannelli For panels <b>L. 159 cm</b>	<b>STRUTTURA BIFRONTA</b>  <b>DOUBLE-SIDED FRAME</b>  	<b>7M8630-GA</b>	Grigio argento Silver grey Gris argenté Gris plata Silbergrau	Per pannelli For panels <b>L. 159 cm</b>									
	<b>7M4630-BO</b>	Bianco opaco Mat white Blanc mat Blanco mate Mattweiß	Per pannelli For panels <b>L. 159 cm</b>		<b>7M8630-BO</b>	Bianco opaco Mat white Blanc mat Blanco mate Mattweiß	Per pannelli For panels <b>L. 159 cm</b>									
	<b>7M4230-GA</b>	Grigio argento Silver grey Gris argenté Gris plata Silbergrau	Per pannelli For panels <b>L. 119 cm</b>		<b>7M8230-GA</b>	Grigio argento Silver grey Gris argenté Gris plata Silbergrau	Per pannelli For panels <b>L. 119 cm</b>									
	<b>7M4230-BO</b>	Bianco opaco Mat white Blanc mat Blanco mate Mattweiß	Per pannelli For panels <b>L. 119 cm</b>		<b>7M8230-BO</b>	Bianco opaco Mat white Blanc mat Blanco mate Mattweiß	Per pannelli For panels <b>L. 119 cm</b>									
	<b>7M4830-GA</b>	Grigio argento Silver grey Gris argenté Gris plata Silbergrau	Per pannelli For panels <b>L. 75 cm</b>		<b>7M8830-GA</b>	Grigio argento Silver grey Gris argenté Gris plata Silbergrau	Per pannelli For panels <b>L. 75 cm</b>									
	<b>7M4830-BO</b>	Bianco opaco Mat white Blanc mat Blanco mate Mattweiß	Per pannelli For panels <b>L. 75 cm</b>		<b>7M8830-BO</b>	Bianco opaco Mat white Blanc mat Blanco mate Mattweiß	Per pannelli For panels <b>L. 75 cm</b>									
		<table border="1"> <tr> <td><b>A</b></td> <td>7M1016-XXXX o/or 7M1016BO-XXXX</td> <td rowspan="2"><b>L. 159 cm</b></td> </tr> <tr> <td><b>B</b></td> <td>7M4630-GA o/or 7M4630-BO</td> </tr> </table>			<b>A</b>	7M1016-XXXX o/or 7M1016BO-XXXX	<b>L. 159 cm</b>	<b>B</b>	7M4630-GA o/or 7M4630-BO	<table border="1"> <tr> <td><b>A</b></td> <td>7M1016-XXXX o/or 7M1016BO-XXXX</td> <td rowspan="2"><b>L. 159 cm</b></td> </tr> <tr> <td><b>B</b></td> <td>7M8630-GA o/or 7M8630-BO</td> </tr> </table>		<b>A</b>	7M1016-XXXX o/or 7M1016BO-XXXX	<b>L. 159 cm</b>	<b>B</b>	7M8630-GA o/or 7M8630-BO
	<b>A</b>	7M1016-XXXX o/or 7M1016BO-XXXX	<b>L. 159 cm</b>													
	<b>B</b>	7M4630-GA o/or 7M4630-BO														
	<b>A</b>	7M1016-XXXX o/or 7M1016BO-XXXX	<b>L. 159 cm</b>													
<b>B</b>	7M8630-GA o/or 7M8630-BO															
o/or		o/or														
<table border="1"> <tr> <td><b>A</b></td> <td>7M1012-XXXX o/or 7M1012BO-XXXX</td> <td rowspan="2"><b>L. 119 cm</b></td> </tr> <tr> <td><b>B</b></td> <td>7M4230-GA o/or 7M4230-BO</td> </tr> </table>	<b>A</b>	7M1012-XXXX o/or 7M1012BO-XXXX	<b>L. 119 cm</b>	<b>B</b>	7M4230-GA o/or 7M4230-BO	o/or		<table border="1"> <tr> <td><b>A</b></td> <td>7M1012-XXXX o/or 7M1012BO-XXXX</td> <td rowspan="2"><b>L. 119 cm</b></td> </tr> <tr> <td><b>B</b></td> <td>7M8230-GA o/or 7M8230-BO</td> </tr> </table>	<b>A</b>	7M1012-XXXX o/or 7M1012BO-XXXX	<b>L. 119 cm</b>	<b>B</b>	7M8230-GA o/or 7M8230-BO			
<b>A</b>	7M1012-XXXX o/or 7M1012BO-XXXX	<b>L. 119 cm</b>														
<b>B</b>	7M4230-GA o/or 7M4230-BO															
<b>A</b>	7M1012-XXXX o/or 7M1012BO-XXXX	<b>L. 119 cm</b>														
<b>B</b>	7M8230-GA o/or 7M8230-BO															
o/or		o/or														
<table border="1"> <tr> <td><b>A</b></td> <td>7M1008-XXXX o/or 7M1008BO-XXXX</td> <td rowspan="2"><b>L. 75 cm</b></td> </tr> <tr> <td><b>B</b></td> <td>7M4830-GA o/or 7M4830-BO</td> </tr> </table>	<b>A</b>	7M1008-XXXX o/or 7M1008BO-XXXX	<b>L. 75 cm</b>	<b>B</b>	7M4830-GA o/or 7M4830-BO	o/or		<table border="1"> <tr> <td><b>A</b></td> <td>7M1008-XXXX o/or 7M1008BO-XXXX</td> <td rowspan="2"><b>L. 75 cm</b></td> </tr> <tr> <td><b>B</b></td> <td>7M8830-GA o/or 7M8830-BO</td> </tr> </table>	<b>A</b>	7M1008-XXXX o/or 7M1008BO-XXXX	<b>L. 75 cm</b>	<b>B</b>	7M8830-GA o/or 7M8830-BO			
<b>A</b>	7M1008-XXXX o/or 7M1008BO-XXXX	<b>L. 75 cm</b>														
<b>B</b>	7M4830-GA o/or 7M4830-BO															
<b>A</b>	7M1008-XXXX o/or 7M1008BO-XXXX	<b>L. 75 cm</b>														
<b>B</b>	7M8830-GA o/or 7M8830-BO															
o/or		o/or														

Struttura in acciaio verniciato con polveri epossidiche con basi in acciaio verniciato con polveri epossidiche per il montaggio di 4 o 8 pannelli Mitesco.

Structure in powder-coated steel with powder-coated steel bases, to mount 4 or 8 Mitesco panels.

Structure en acier peint époxy avec bases en acier peint époxy pour le montage de 4 ou 8 panneaux Mitesco.

Estructura de acero recubierto epoxi con bases de acero recubierto epoxi para el montaje de 4 o 8 paneles Mitesco.

Standsäulen aus pulverbeschichtetem Stahl mit Fuß aus pulverbeschichtetem Stahl zur Aufstellung von 4 oder 8 Mitesco-Paneelen.

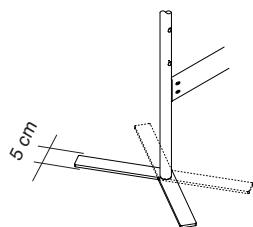

Dettaglio della base. La base può essere montata in due posizioni, interna o esterna.  
Detail of the base. The base can be mounted in two positions, internal or external.

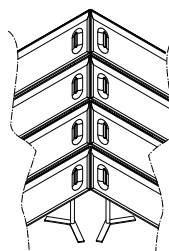

Nelle composizioni ad angolo, l'utilizzo di questa base permette il perfetto accostamento dei pannelli.  
In the corner compositions the use of this base allows the perfect approaching of the panels.

# MITESCO DIVIDER

design Michele De Lucchi  
Snowsound® technology by Caimi Brevetti

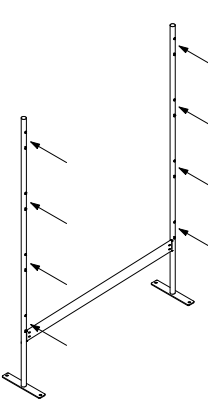
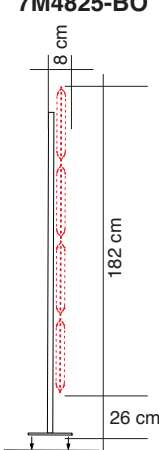
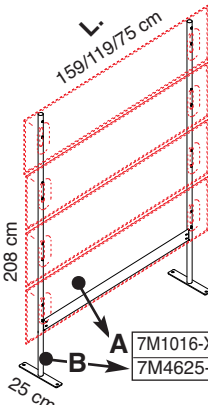
	Codice Code	Colore Colour	Prezzo Price																						
<b>STRUTTURA MONOFRONTALE</b>  <b>ONE-SIDED FRAME</b> 	<b>7M4625-GA</b>	Grigio argento Silver grey Gris argenté Gris plata Silbergrau	Per pannelli For panels <b>L. 159 cm</b>																						
	<b>7M4625-BO</b>	Bianco opaco Mat white Blanc mat Blanco mate Mattweiß	Per pannelli For panels <b>L. 159 cm</b>																						
	<b>7M4225-GA</b>	Grigio argento Silver grey Gris argenté Gris plata Silbergrau	Per pannelli For panels <b>L. 119 cm</b>																						
	<b>7M4225-BO</b>	Bianco opaco Mat white Blanc mat Blanco mate Mattweiß	Per pannelli For panels <b>L. 119 cm</b>																						
	<b>7M4825-GA</b>	Grigio argento Silver grey Gris argenté Gris plata Silbergrau	Per pannelli For panels <b>L. 75 cm</b>																						
	<b>7M4825-BO</b>	Bianco opaco Mat white Blanc mat Blanco mate Mattweiß	Per pannelli For panels <b>L. 75 cm</b>																						
																									
																									
	<table border="1"> <tr> <td><b>A</b></td> <td>7M1016-XXXX o/or 7M1016BO-XXXX</td> <td rowspan="2"><b>L. 159 cm</b></td> </tr> <tr> <td><b>B</b></td> <td>7M4625-GA o/or 7M4625-BO</td> </tr> <tr> <td colspan="3" style="text-align: center;">o/or</td> </tr> <tr> <td><b>A</b></td> <td>7M1012-XXXX o/or 7M1012BO-XXXX</td> <td rowspan="2"><b>L. 119 cm</b></td> </tr> <tr> <td><b>B</b></td> <td>7M4225-GA o/or 7M4225-BO</td> </tr> <tr> <td colspan="3" style="text-align: center;">o/or</td> </tr> <tr> <td><b>A</b></td> <td>7M1008-XXXX o/or 7M1008BO-XXXX</td> <td rowspan="2"><b>L. 75 cm</b></td> </tr> <tr> <td><b>B</b></td> <td>7M4825-GA o/or 7M4825-BO</td> </tr> </table>			<b>A</b>	7M1016-XXXX o/or 7M1016BO-XXXX	<b>L. 159 cm</b>	<b>B</b>	7M4625-GA o/or 7M4625-BO	o/or			<b>A</b>	7M1012-XXXX o/or 7M1012BO-XXXX	<b>L. 119 cm</b>	<b>B</b>	7M4225-GA o/or 7M4225-BO	o/or			<b>A</b>	7M1008-XXXX o/or 7M1008BO-XXXX	<b>L. 75 cm</b>	<b>B</b>	7M4825-GA o/or 7M4825-BO	
	<b>A</b>	7M1016-XXXX o/or 7M1016BO-XXXX	<b>L. 159 cm</b>																						
	<b>B</b>	7M4625-GA o/or 7M4625-BO																							
	o/or																								
<b>A</b>	7M1012-XXXX o/or 7M1012BO-XXXX	<b>L. 119 cm</b>																							
<b>B</b>	7M4225-GA o/or 7M4225-BO																								
o/or																									
<b>A</b>	7M1008-XXXX o/or 7M1008BO-XXXX	<b>L. 75 cm</b>																							
<b>B</b>	7M4825-GA o/or 7M4825-BO																								

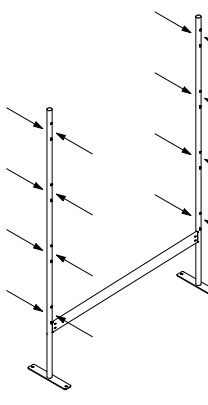
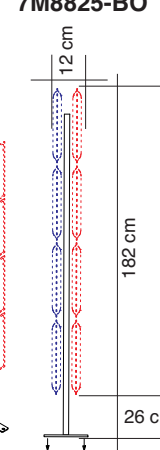
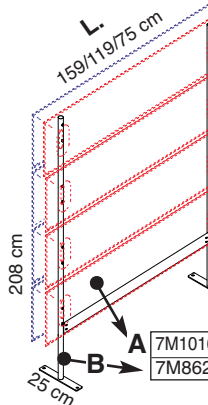
	Codice Code	Colore Colour	Prezzo Price																						
<b>STRUTTURA BIFRONTALE</b>  <b>DOUBLE-SIDED FRAME</b> 	<b>7M8625-GA</b>	Grigio argento Silver grey Gris argenté Gris plata Silbergrau	Per pannelli For panels <b>L. 159 cm</b>																						
	<b>7M8625-BO</b>	Bianco opaco Mat white Blanc mat Blanco mate Mattweiß	Per pannelli For panels <b>L. 159 cm</b>																						
	<b>7M8225-GA</b>	Grigio argento Silver grey Gris argenté Gris plata Silbergrau	Per pannelli For panels <b>L. 119 cm</b>																						
	<b>7M8225-BO</b>	Bianco opaco Mat white Blanc mat Blanco mate Mattweiß	Per pannelli For panels <b>L. 119 cm</b>																						
	<b>7M8825-GA</b>	Grigio argento Silver grey Gris argenté Gris plata Silbergrau	Per pannelli For panels <b>L. 75 cm</b>																						
	<b>7M8825-BO</b>	Bianco opaco Mat white Blanc mat Blanco mate Mattweiß	Per pannelli For panels <b>L. 75 cm</b>																						
																									
																									
	<table border="1"> <tr> <td><b>A</b></td> <td>7M1016-XXXX o/or 7M1016BO-XXXX</td> <td rowspan="2"><b>L. 159 cm</b></td> </tr> <tr> <td><b>B</b></td> <td>7M8625-GA o/or 7M8625-BO</td> </tr> <tr> <td colspan="3" style="text-align: center;">o/or</td> </tr> <tr> <td><b>A</b></td> <td>7M1012-XXXX o/or 7M1012BO-XXXX</td> <td rowspan="2"><b>L. 119 cm</b></td> </tr> <tr> <td><b>B</b></td> <td>7M8225-GA o/or 7M8225-BO</td> </tr> <tr> <td colspan="3" style="text-align: center;">o/or</td> </tr> <tr> <td><b>A</b></td> <td>7M1008-XXXX o/or 7M1008BO-XXXX</td> <td rowspan="2"><b>L. 75 cm</b></td> </tr> <tr> <td><b>B</b></td> <td>7M8825-GA o/or 7M8825-BO</td> </tr> </table>			<b>A</b>	7M1016-XXXX o/or 7M1016BO-XXXX	<b>L. 159 cm</b>	<b>B</b>	7M8625-GA o/or 7M8625-BO	o/or			<b>A</b>	7M1012-XXXX o/or 7M1012BO-XXXX	<b>L. 119 cm</b>	<b>B</b>	7M8225-GA o/or 7M8225-BO	o/or			<b>A</b>	7M1008-XXXX o/or 7M1008BO-XXXX	<b>L. 75 cm</b>	<b>B</b>	7M8825-GA o/or 7M8825-BO	
	<b>A</b>	7M1016-XXXX o/or 7M1016BO-XXXX	<b>L. 159 cm</b>																						
	<b>B</b>	7M8625-GA o/or 7M8625-BO																							
	o/or																								
<b>A</b>	7M1012-XXXX o/or 7M1012BO-XXXX	<b>L. 119 cm</b>																							
<b>B</b>	7M8225-GA o/or 7M8225-BO																								
o/or																									
<b>A</b>	7M1008-XXXX o/or 7M1008BO-XXXX	<b>L. 75 cm</b>																							
<b>B</b>	7M8825-GA o/or 7M8825-BO																								

Struttura in acciaio verniciato con polveri epossidiche con basi in acciaio verniciato con polveri epossidiche per fissaggio a terra (viti non incluse) per il montaggio di **4 o 8** pannelli Mitesco.

Structure in powder-coated steel with powder-coated steel bases for floor fixing (screws not included), to mount **4 or 8** Mitesco panels.

Structure en acier peint époxy avec bases en acier peint époxy pour fixation au sol (vis pas incluses) pour le montage de **4 ou 8** panneaux Mitesco.

Estructura de acero recubierto epoxi con bases de acero recubierto epoxi para fijación al suelo (tornillos no incluidos) para el montaje de **4 o 8** paneles Mitesco.

Standssäulen aus pulverbeschichtetem Stahl mit Fuß zur Bodenbefestigung (Schrauben nicht inkludiert) aus pulverbeschichtetem Stahl zur Aufstellung von **4 oder 8** Mitesco-Paneeelen.

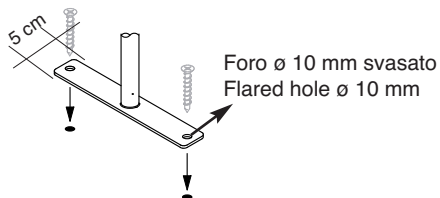

Foro ø 10 mm svasato  
Flared hole ø 10 mm

Dettaglio della base (viti non incluse)  
Detail of the base (screws not included)  
Détail de la base (vis pas incluses)  
Detalle de la base (tornillos no incluidos)  
Details der Basis (Schrauben nicht inkludiert)

# MITESCO DIVIDER

design Michele De Lucchi  
Snowsound® technology by Caimi Brevetti

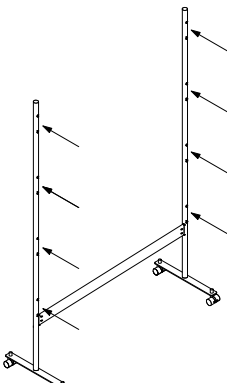
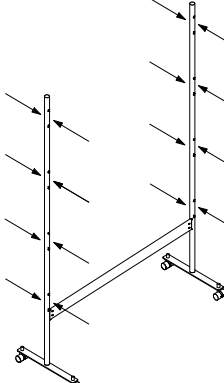
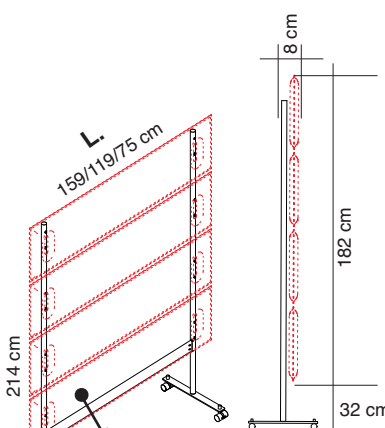
	Codice Code	Colore Colour	Prezzo Price		Codice Code	Colore Colour	Prezzo Price									
<b>STRUTTURA MONOFRONTALE</b> <b>ONE-SIDED FRAME</b> 	<b>7M4660-RGA</b>	Grigio argento Silver grey Gris argenté Gris plata Silbergrau	Per pannelli For panels <b>L. 159 cm</b>	<b>STRUTTURA BIFRONTALE</b> <b>DOUBLE-SIDED FRAME</b> 	<b>7M8660-RGA</b>	Grigio argento Silver grey Gris argenté Gris plata Silbergrau	Per pannelli For panels <b>L. 159 cm</b>									
	<b>7M4660-RBO</b>	Bianco opaco Mat white Blanc mat Blanco mate Mattweiß	Per pannelli For panels <b>L. 159 cm</b>		<b>7M8660-RBO</b>	Bianco opaco Mat white Blanc mat Blanco mate Mattweiß	Per pannelli For panels <b>L. 159 cm</b>									
	<b>7M4260-RGA</b>	Grigio argento Silver grey Gris argenté Gris plata Silbergrau	Per pannelli For panels <b>L. 119 cm</b>		<b>7M8260-RGA</b>	Grigio argento Silver grey Gris argenté Gris plata Silbergrau	Per pannelli For panels <b>L. 119 cm</b>									
	<b>7M4260-RBO</b>	Bianco opaco Mat white Blanc mat Blanco mate Mattweiß	Per pannelli For panels <b>L. 119 cm</b>		<b>7M8260-RBO</b>	Bianco opaco Mat white Blanc mat Blanco mate Mattweiß	Per pannelli For panels <b>L. 119 cm</b>									
	<b>7M4860-RGA</b>	Grigio argento Silver grey Gris argenté Gris plata Silbergrau	Per pannelli For panels <b>L. 75 cm</b>		<b>7M8860-RGA</b>	Grigio argento Silver grey Gris argenté Gris plata Silbergrau	Per pannelli For panels <b>L. 75 cm</b>									
	<b>7M4860-RBO</b>	Bianco opaco Mat white Blanc mat Blanco mate Mattweiß	Per pannelli For panels <b>L. 75 cm</b>		<b>7M8860-RBO</b>	Bianco opaco Mat white Blanc mat Blanco mate Mattweiß	Per pannelli For panels <b>L. 75 cm</b>									
		<table border="1"> <tr> <td>A</td> <td>7M1016-XXXX o/or 7M1016BO-XXXX</td> <td rowspan="2"><b>L. 159 cm</b></td> </tr> <tr> <td>B</td> <td>7M4660-RGA o/or 7M4660-RBO</td> </tr> </table>			A	7M1016-XXXX o/or 7M1016BO-XXXX	<b>L. 159 cm</b>	B	7M4660-RGA o/or 7M4660-RBO	<table border="1"> <tr> <td>A</td> <td>7M1016-XXXX o/or 7M1016BO-XXXX</td> <td rowspan="2"><b>L. 159 cm</b></td> </tr> <tr> <td>B</td> <td>7M8660R-GA o/or 7M8660-RBO</td> </tr> </table>		A	7M1016-XXXX o/or 7M1016BO-XXXX	<b>L. 159 cm</b>	B	7M8660R-GA o/or 7M8660-RBO
	A	7M1016-XXXX o/or 7M1016BO-XXXX	<b>L. 159 cm</b>													
	B	7M4660-RGA o/or 7M4660-RBO														
	A	7M1016-XXXX o/or 7M1016BO-XXXX	<b>L. 159 cm</b>													
B	7M8660R-GA o/or 7M8660-RBO															
o/or		o/or														
<table border="1"> <tr> <td>A</td> <td>7M1012-XXXX o/or 7M1012BO-XXXX</td> <td rowspan="2"><b>L. 119 cm</b></td> </tr> <tr> <td>B</td> <td>7M4260-RGA o/or 7M4260-RBO</td> </tr> </table>	A	7M1012-XXXX o/or 7M1012BO-XXXX	<b>L. 119 cm</b>	B	7M4260-RGA o/or 7M4260-RBO	o/or		<table border="1"> <tr> <td>A</td> <td>7M1012-XXXX o/or 7M1012BO-XXXX</td> <td rowspan="2"><b>L. 119 cm</b></td> </tr> <tr> <td>B</td> <td>7M8260-RGA o/or 7M8260-RBO</td> </tr> </table>	A	7M1012-XXXX o/or 7M1012BO-XXXX	<b>L. 119 cm</b>	B	7M8260-RGA o/or 7M8260-RBO			
A	7M1012-XXXX o/or 7M1012BO-XXXX	<b>L. 119 cm</b>														
B	7M4260-RGA o/or 7M4260-RBO															
A	7M1012-XXXX o/or 7M1012BO-XXXX	<b>L. 119 cm</b>														
B	7M8260-RGA o/or 7M8260-RBO															
o/or		o/or														
<table border="1"> <tr> <td>A</td> <td>7M1008-XXXX o/or 7M1008BO-XXXX</td> <td rowspan="2"><b>L. 75 cm</b></td> </tr> <tr> <td>B</td> <td>7M4860-RGA o/or 7M4860-RBO</td> </tr> </table>	A	7M1008-XXXX o/or 7M1008BO-XXXX	<b>L. 75 cm</b>	B	7M4860-RGA o/or 7M4860-RBO	o/or		<table border="1"> <tr> <td>A</td> <td>7M1008-XXXX o/or 7M1008BO-XXXX</td> <td rowspan="2"><b>L. 75 cm</b></td> </tr> <tr> <td>B</td> <td>7M8860-RGA o/or 7M8860-RBO</td> </tr> </table>	A	7M1008-XXXX o/or 7M1008BO-XXXX	<b>L. 75 cm</b>	B	7M8860-RGA o/or 7M8860-RBO			
A	7M1008-XXXX o/or 7M1008BO-XXXX	<b>L. 75 cm</b>														
B	7M4860-RGA o/or 7M4860-RBO															
A	7M1008-XXXX o/or 7M1008BO-XXXX	<b>L. 75 cm</b>														
B	7M8860-RGA o/or 7M8860-RBO															

Struttura in acciaio verniciato con polveri epossidiche con basi in acciaio verniciato con polveri epossidiche con ruote in tecnopolimero (2 con freno e 2 senza) per il montaggio di 4 o 8 pannelli Mitesco.

Structure in powder-coated steel with powder-coated steel bases with high-tech polymer castors (2 with and 2 without brakes), to mount 4 or 8 Mitesco panels.

Structure en acier peint époxy avec bases en acier peint époxy et roulettes en technopolymère (2 avec freins et 2 sans) pour le montage de 4 ou 8 panneaux Mitesco.

Estructura de acero recubierto epoxi con bases de acero recubierto epoxi con ruedas en polimero (2 con freno y 2 sin) para el montaje de 4 o 8 paneles Mitesco.

Standssäulen aus pulverbeschichtetem Stahl mit Standfuß aus pulverbeschichtetem Stahl mit Rollen aus Technopolymer (2 davon feststellbar) zur Aufstellung von 4 oder 8 Mitesco-Paneeelen.

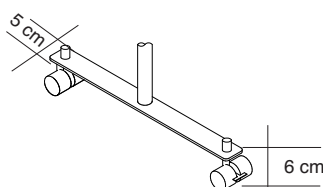

Dettaglio della base  
Detail of the base  
Détail de la base  
Detaille de la base  
Details der Basis



ø 4 cm

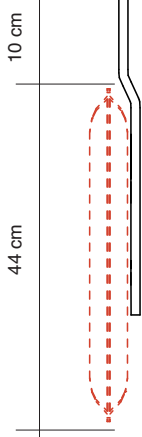
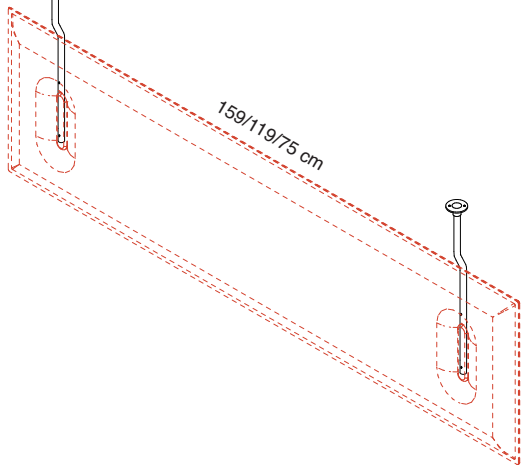
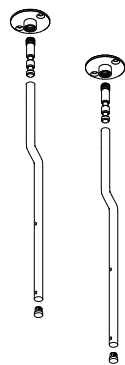

**Codice**  
**Code**

**7MBF50**

**Colore**  
**Colour**

Cromato  
Chrome-plated  
Chromé  
Cromado  
Verchromt

**Prezzo**  
**Price**

**1 coppia / 1 pair**  
**1 paire / 1 pare**  
**1 Paar**

**Descrizione**  
**Description**

Kit per fissaggio a soffitto di 1 pannello Mitesco in posizione verticale (baffle) composto da: 2 piastre a soffitto a 2 fori, 2 supporti (tubi) sagomati in acciaio cromato. Per questo tipo di appendimento a soffitto del pannello il profilo livellatore non è necessario

Kit for the ceiling fixing of 1 Mitesco panel in vertical position (baffle) composed of: 2 ceiling plates with 2 holes, 2 shaped supports (tubes) in chrome-plated steel. For this kind of ceiling hanging of the panel the leveler profile is not necessary.

Kit d'accrochage au plafond d'un panneau Mitesco en position verticale (baffle) composé de: 2 plaques à plafond à 2 trous, 2 supports (tubes) façonnés en acier chromé. Pour ce type d'accrochage du panneau au plafond, il ne faut aucun profil niveleur.

Kit para el montaje al techo de 1 panel Mitesco en posición vertical (baffle) compuesto por 2 placas de techo con 2 huecos, 2 soportes (tubos) conformados de acero cromado. Para ese tipo de montaje al techo del panel no es necesario el perfil nivelador.

Set zur Deckenbefestigung in vertikaler Position (Baffle) für 1 Mitesco-Panel, bestehend aus: 2 Deckenmontageplatten mit 2 Befestigungsbohrungen, 2 gebogene Halterungen (Rohre) aus verchromtem Stahl. Für diese Art der Deckenbefestigung ist das Justierprofil nicht notwendig.



# MITESCO CEILING

design Michele De Lucchi  
Snowsound® technology by Caimi Brevetti

Codice Code	Colore Colour	Prezzo Price	Descrizione Description
7MBC51	Cromato Chrome-plated Chromé Cromado Verchromt	1 coppia / 1 pair 1 paire / 1 pare 1 Paar	<p>Kit per fissaggio a soffitto di 1 pannello Mitesco in posizione verticale (baffle) composto da: 2 piastre a soffitto a 2 fori, 2 cavi, 2 supporti (tubi) sagomati in acciaio cromato. Per questo tipo di appendimento a soffitto del pannello il profilo livellatore non è necessario</p> <p>Kit for the ceiling fixing of 1 Mitesco panel in vertical position (baffle) composed of: 2 ceiling plates with 2 holes, 2 cables, 2 shaped supports (tubes) in chrome-plated steel. For this kind of ceiling hanging of the panel the leveler profile is not necessary.</p> <p>Kit d'accrochage au plafond d'un panneau Mitesco en position verticale (baffle) composé de: 2 plaques à plafond à 2 trous, 2 cables, 2 supports (tubes) façonnés en acier chromé. Pour ce type d'accrochage du panneau au plafond, il ne faut aucun profil niveleur.</p> <p>Kit para el montaje al techo de 1 panel Mitesco en posición vertical (baffle) compuesto por 2 placas de techo con 2 huecos, 2 cables, 2 soportes (tubos) conformados de acero cromado. Para ese tipo de montaje al techo del panel no es necesario el perfil nivelador.</p> <p>Set zur Deckenbefestigung in vertikaler Position (Baffel) für 1 Mitesco-Paneel, bestehend aus: 2 Deckenmontageplatten mit 2 Befestigungsbohrungen, 2 Stahlseile, 2 gebogene Halterungen (Rohre) aus verchromtem Stahl. Für diese Art der Deckenbefestigung ist das Justierprofil nicht notwendig.</p>

7MBC53	Cromato Chrome-plated Chromé Cromado Verchromt	1 coppia / 1 pair 1 paire / 1 pare 1 Paar	<p>Kit per fissaggio a soffitto di 1 pannello Mitesco in posizione verticale (baffle) composto da: 2 attacchi a soffitto filettati M6, 2 cavi, 2 supporti (tubi) sagomati in acciaio cromato. Per questo tipo di appendimento a soffitto del pannello il profilo livellatore non è necessario</p> <p>Kit for the ceiling fixing of 1 Mitesco panel in vertical position (baffle) composed of: 2 ceiling hanging threaded M6, 2 cables, 2 shaped supports (tubes) in chrome-plated steel. For this kind of ceiling hanging of the panel the leveler profile is not necessary.</p> <p>Kit d'accrochage au plafond d'un panneau Mitesco en position verticale (baffle) composé de: 2 accrochages au plafond filetés M6, 2 cables, 2 supports (tubes) façonnés en acier chromé. Pour ce type d'accrochage du panneau au plafond, il ne faut aucun profil niveleur.</p> <p>Kit para el montaje al techo de 1 panel Mitesco en posición vertical (baffle) compuesto por 2 fijaciones al techo roscadas M6, 2 cables, 2 soportes (tubos) conformados de acero cromado. Para ese tipo de montaje al techo del panel no es necesario el perfil nivelador.</p> <p>Set zur Deckenbefestigung in vertikaler Position (Baffel) für 1 Mitesco-Paneel, bestehend aus: 2 Deckenbefestigungen für Gewinde M6, 2 Stahlseile, 2 gebogene Halterungen (Rohre) aus verchromtem Stahl. Für diese Art der Deckenbefestigung ist das Justierprofil nicht notwendig.</p>
--------	------------------------------------------------------------	-------------------------------------------------	-------------------------------------------------------------------------------------------------------------------------------------------------------------------------------------------------------------------------------------------------------------------------------------------------------------------------------------------------------------------------------------------------------------------------------------------------------------------------------------------------------------------------------------------------------------------------------------------------------------------------------------------------------------------------------------------------------------------------------------------------------------------------------------------------------------------------------------------------------------------------------------------------------------------------------------------------------------------------------------------------------------------------------------------------------------------------------------------------------------------------------------------------------------------------------------------------------------------------------------------------------------------------------------------------------------------------------------------------------------------------------------------------------------------------------------------------

# MITESCO CEILING

design Michele De Lucchi  
Snowsound® technology by Caimi Brevetti

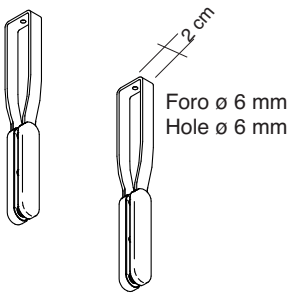
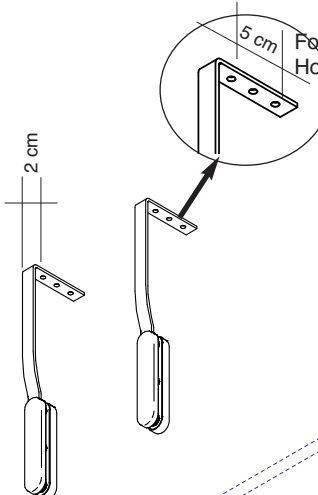
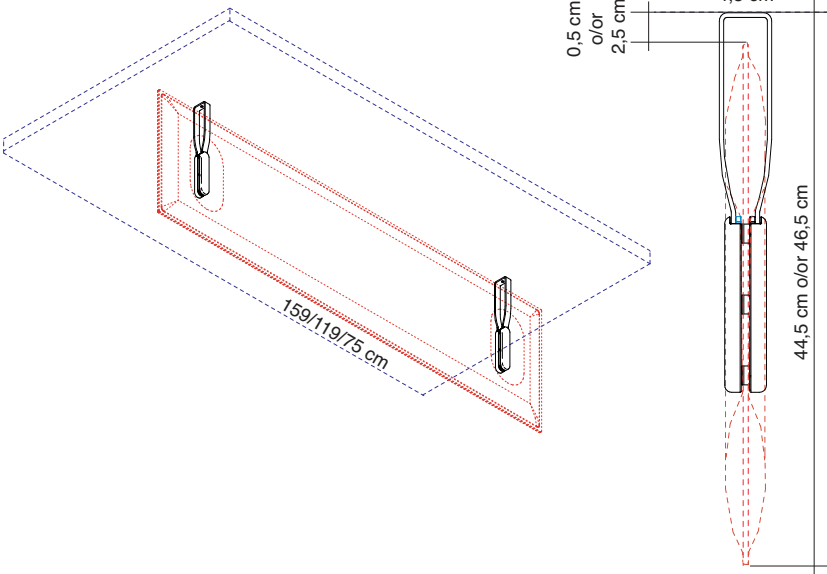
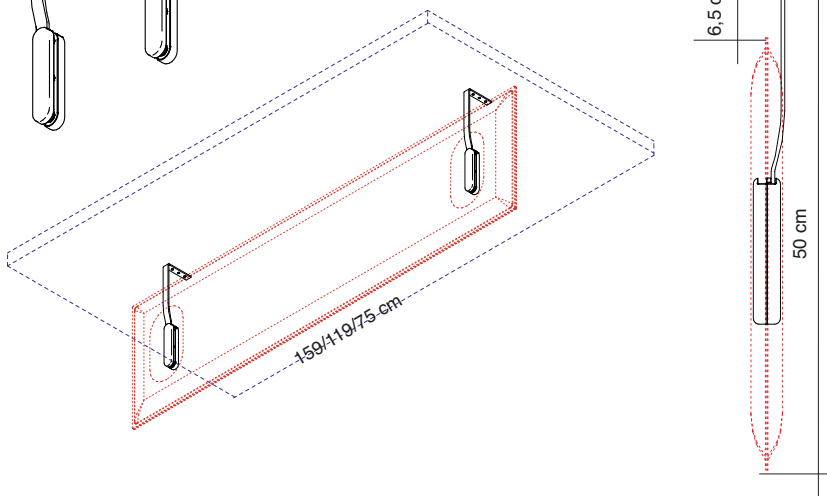
	Codice Code	Colore Colour	Prezzo Price	Descrizione Description
	<b>7M511-GA</b>	Grigio argento Silver grey Gris argenté Gris plata Silbergrau	<b>1 coppia / 1 pair 1 paire / 1 pare 1 Paar</b>	Coppia staffe in acciaio verniciato con polveri epossidiche per fissaggio a soffitto tramite viti (non incluse). Attacchi al pannello e coperture in tecnopolimero grigio o bianco. <b>Per pannelli Mitesco Desk pag. 56.</b>
	<b>7M511-BO</b>	Bianco opaco Mat white Blanc mat Blanco mate Mattweiß	<b>1 coppia / 1 pair 1 paire / 1 pare 1 Paar</b>	Pair of brackets in powder-coated steel to be fixed to the ceiling with screws (not included). Panel connections and front covers in grey or white high-tech polymer. <b>For Mitesco Desk panels page 56.</b>
	<b>7M515-GA</b>	Grigio argento Silver grey Gris argenté Gris plata Silbergrau	<b>1 coppia / 1 pair 1 paire / 1 pare 1 Paar</b>	Coppia staffe in acciaio verniciato con polveri epossidiche per fissaggio a soffitto tramite viti (non incluse). Attacchi al pannello e coperture in tecnopolimero grigio o bianco. <b>Per pannelli Mitesco Desk pag. 56.</b>
	<b>7M515-BO</b>	Bianco opaco Mat white Blanc mat Blanco mate Mattweiß	<b>1 coppia / 1 pair 1 paire / 1 pare 1 Paar</b>	Pair of brackets in powder-coated steel to be fixed to the ceiling with screws (not included). Panel connections and front covers in grey or white high-tech polymer. <b>For Mitesco Desk panels page 56.</b>
				<p>Paire d'étriers en acier peint en époxy pour fixation au plafond par des vis (pas incluses). Jonctions au panneau et couvertures en technopolymère gris ou blanc. <b>Pour Mitesco Desk panneaux page 56.</b></p> <p>Par de abrazaderas de acero recubierto epoxi para fijación al techo con tornillos (no incluidos). Enganches al panel y coberturas de polímero gris o blanco. <b>Para Mitesco Desk panels page 56.</b></p> <p>1 Paar Halterungen aus pulverbeschichtetem Stahl zur Deckenbefestigung mittels Schrauben (nicht inkludiert). Paneelbefestigungen und Abdeckungen aus grauem oder weißem Technopolymer. <b>Für Mitesco Desk Paneele, Seite 56.</b></p>
				<p>Paire d'étriers en acier peint en époxy pour fixation au plafond par des vis (pas incluses). Jonctions au panneau et couvertures en technopolymère gris ou blanc. <b>Pour Mitesco Desk panneaux page 56.</b></p> <p>Par de abrazaderas de acero recubierto epoxi para fijación al techo con tornillos (no incluidos). Enganches al panel y coberturas de polímero gris o blanco. <b>Para Mitesco Desk panels page 56.</b></p> <p>1 Paar Halterungen aus pulverbeschichtetem Stahl zur Deckenbefestigung mittels Schrauben (nicht inkludiert). Paneelbefestigungen und Abdeckungen aus grauem oder weißem Technopolymer. <b>Für Mitesco Desk Paneele, Seite 56.</b></p>
				<p>Paire d'étriers en acier peint en époxy pour fixation au plafond par des vis (pas incluses). Jonctions au panneau et couvertures en technopolymère gris ou blanc. <b>Pour Mitesco Desk panneaux page 56.</b></p> <p>Par de abrazaderas de acero recubierto epoxi para fijación al techo con tornillos (no incluidos). Enganches al panel y coberturas de polímero gris o blanco. <b>Para Mitesco Desk panels page 56.</b></p> <p>1 Paar Halterungen aus pulverbeschichtetem Stahl zur Deckenbefestigung mittels Schrauben (nicht inkludiert). Paneelbefestigungen und Abdeckungen aus grauem oder weißem Technopolymer. <b>Für Mitesco Desk Paneele, Seite 56.</b></p>
				<p>Paire d'étriers en acier peint en époxy pour fixation au plafond par des vis (pas incluses). Jonctions au panneau et couvertures en technopolymère gris ou blanc. <b>Pour Mitesco Desk panneaux page 56.</b></p> <p>Par de abrazaderas de acero recubierto epoxi para fijación al techo con tornillos (no incluidos). Enganches al panel y coberturas de polímero gris o blanco. <b>Para Mitesco Desk panels page 56.</b></p> <p>1 Paar Halterungen aus pulverbeschichtetem Stahl zur Deckenbefestigung mittels Schrauben (nicht inkludiert). Paneelbefestigungen und Abdeckungen aus grauem oder weißem Technopolymer. <b>Für Mitesco Desk Paneele, Seite 56.</b></p>

# MITESCO CEILING

design Michele De Lucchi  
Snowsound® technology by Caimi Brevetti

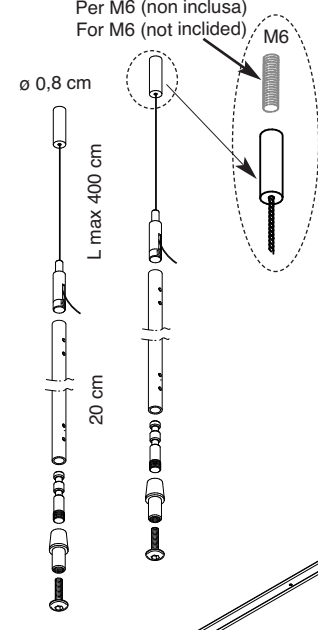
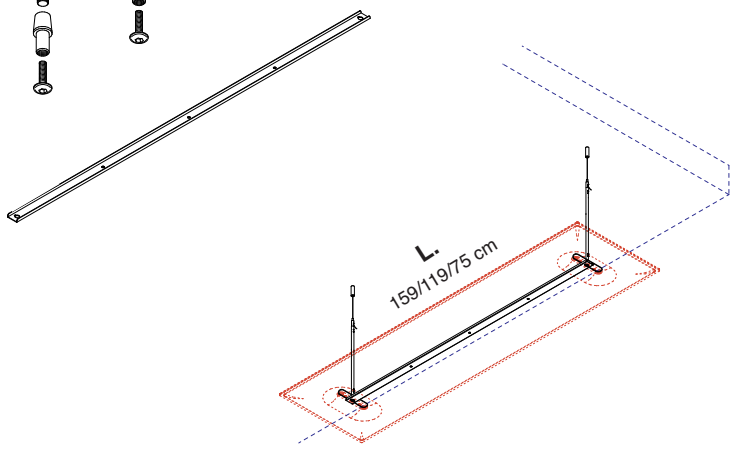
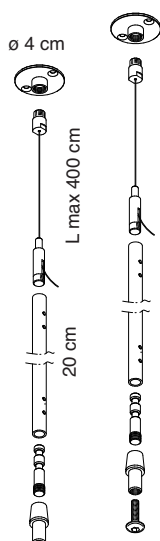
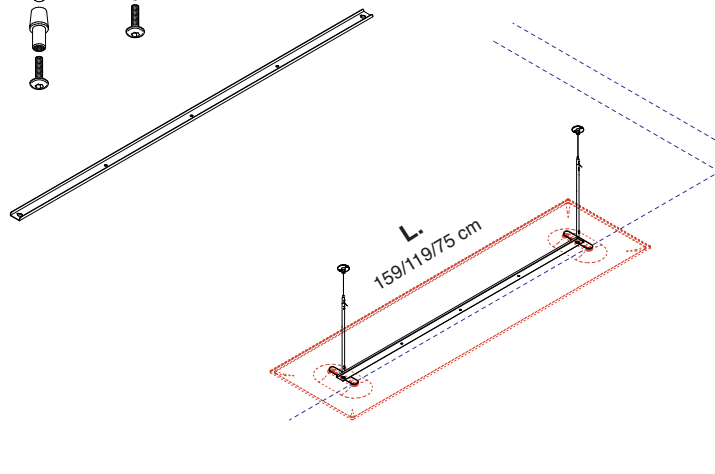
	Codice Code	Colore Colour	Prezzo Price	Descrizione Description
<p>Per M6 (non inclusa) For M6 (not included)</p>  	<p><b>7MCC2116</b></p>	<p>Cromato Chrome-plated Chromé Cromado Verchromt</p>	<p><b>Per pannelli For panels L. 159 cm</b></p>	<p>Kit per fissaggio a soffitto di un pannello Mitesco in posizione orizzontale composto da: 2 attacchi a soffitto filettati M6, 2 cavi, 2 supporti (tubi) in acciaio cromato, 2 attacchi per pannello, 1 profilo livellatore.</p>
	<p><b>7MCC2112</b></p>	<p>Cromato Chrome-plated Chromé Cromado Verchromt</p>	<p><b>Per pannelli For panels L. 119 cm</b></p>	<p>Kit for the ceiling fixing of a Mitesco panel in horizontal position composed of: 2 ceiling hanging threaded M6, 2 supports (tubes) in chrome-plated steel, 2 cables, 2 hangings for the panel, 1 leveler profile.</p>
	<p><b>7MCC2108</b></p>	<p>Cromato Chrome-plated Chromé Cromado Verchromt</p>	<p><b>Per pannelli For panels L. 75 cm</b></p>	<p>Kit d'accrochage au plafond d'un panneau Mitesco en position horizontale composé de: 2 accrochages au plafond filetés M6, 2 supports (tubes) en acier chromé, 2 cables, 2 accrochages pour panneau, 1 profil niveleur.</p> <p>Kit para el montaje al techo de 1 panel Mitesco en posición horizontal compuesto por: 2 fijaciones al techo roscadas M6, 2 soportes (tubos) de acero cromado, 2 cables, 2 enganches para el panel, 1 perfil nivelador.</p> <p>Set für die Deckenbefestigung eines Mitesco-Panels in horizontaler Position, bestehend aus: 2 Deckenbefestigungen für Gewinde M6, 2 Halterungen (Rohre) aus verchromtem Stahl, 2 Stahlseile, 2 Paneelbefestigungen, 1 Justierprofil.</p>
 	<p><b>7MCC2216</b></p>	<p>Cromato Chrome-plated Chromé Cromado Verchromt</p>	<p><b>Per pannelli For panels L. 159 cm</b></p>	<p>Kit per fissaggio a soffitto di un pannello Mitesco in posizione orizzontale composto da: 2 piastre a soffitto a 2 fori, 2 supporti (tubi) in acciaio cromato, 2 cavi, 2 attacchi per pannello, 1 profilo livellatore.</p>
	<p><b>7MCC2212</b></p>	<p>Cromato Chrome-plated Chromé Cromado Verchromt</p>	<p><b>Per pannelli For panels L. 119 cm</b></p>	<p>Kit for the ceiling fixing of a Mitesco panel in horizontal position composed of: 2 ceiling plates with 2 holes, 2 supports (tubes) in chrome-plated steel, 2 cables, 2 hangings for the panel, 1 leveler profile.</p>
	<p><b>7MCC2208</b></p>	<p>Cromato Chrome-plated Chromé Cromado Verchromt</p>	<p><b>Per pannelli For panels L. 75 cm</b></p>	<p>Kit d'accrochage au plafond d'un panneau Mitesco en position horizontale composé de: 2 plaques pour plafond à 2 trous, 2 supports (tubes) en acier chromé, 2 cables, 2 accrochages pour panneau, 1 profil niveleur.</p> <p>Kit para el montaje al techo de 1 panel Mitesco en posición horizontal compuesto por: 2 placas de techo con 2 huecos, 2 soportes (tubos) de acero cromado, 2 cables, 2 enganches para el panel, 1 perfil nivelador.</p> <p>Set für die Deckenbefestigung eines Mitesco-Panels in horizontaler Position, bestehend aus: 2 Deckenmontageplatten mit 2 Befestigungsbohrungen, 2 Halterungen (Rohre) aus verchromtem Stahl, 2 Stahlseile, 2 Paneelbefestigungen, 1 Justierprofil.</p>

# MITESCO CEILING

design Michele De Lucchi  
Snowsound® technology by Caimi Brevetti

	Codice Code	Colore Colour	Prezzo Price	Descrizione Description
	<b>7MCF0116</b>	Cromato Chrome-plated Chromé Cromado Verchromt	<b>Per pannelli For panels L. 159 cm</b>	Kit per fissaggio a soffitto di un pannello Mitesco in posizione orizzontale composto da: 2 piastre a soffitto a 2 fori, 2 supporti (tubi) in acciaio cromato, 2 attacchi per pannello, 1 profilo livellatore.
	<b>7MCF0112</b>	Cromato Chrome-plated Chromé Cromado Verchromt	<b>Per pannelli For panels L. 119 cm</b>	Kit for the ceiling fixing of a Mitesco panel in horizontal position composed of: 2 ceiling plates with 2 holes, 2 supports (tubes) in chrome-plated steel, 2 hangings for the panel, 1 leveler profile.
	<b>7MCF0108</b>	Cromato Chrome-plated Chromé Cromado Verchromt	<b>Per pannelli For panels L. 75 cm</b>	Kit d'accrochage au plafond d'un panneau Mitesco en position horizontale composé de: 2 plaques pour plafond à 2 trous, 2 supports (tubes) en acier chromé, 2 accrochages pour panneau, 1 profil niveleur.
	<b>7MCF0216</b>	Cromato Chrome-plated Chromé Cromado Verchromt	<b>Per pannelli For panels L. 159 cm</b>	Kit per fissaggio a soffitto di un pannello Mitesco in posizione orizzontale composto da: 2 piastre a soffitto a 2 fori, 2 supporti (tubi) in acciaio cromato, 2 attacchi per pannello, 1 profilo livellatore.
	<b>7MCF0212</b>	Cromato Chrome-plated Chromé Cromado Verchromt	<b>Per pannelli For panels L. 119 cm</b>	Kit for the ceiling fixing of a Mitesco panel in horizontal position composed of: 2 ceiling plates with 2 holes, 2 supports (tubes) in chrome-plated steel, 2 hangings for the panel, 1 leveler profile.
	<b>7MCF0208</b>	Cromato Chrome-plated Chromé Cromado Verchromt	<b>Per pannelli For panels L. 75 cm</b>	Kit d'accrochage au plafond d'un panneau Mitesco en position horizontale composé de: 2 plaques pour plafond à 2 trous, 2 supports (tubes) en acier chromé, 2 accrochages pour panneau, 1 profil niveleur.

# MITESCO CEILING

design Michele De Lucchi  
Snowsound® technology by Caimi Brevetti

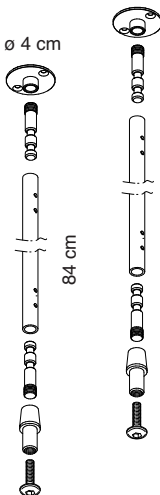
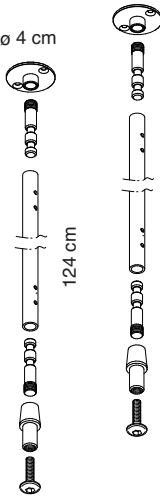
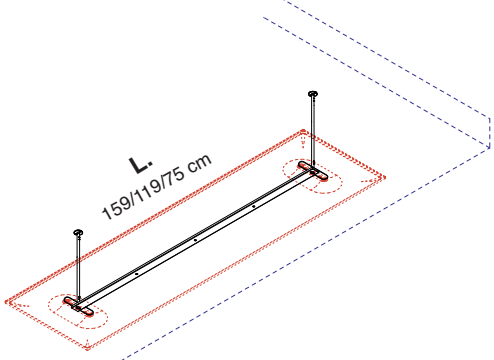
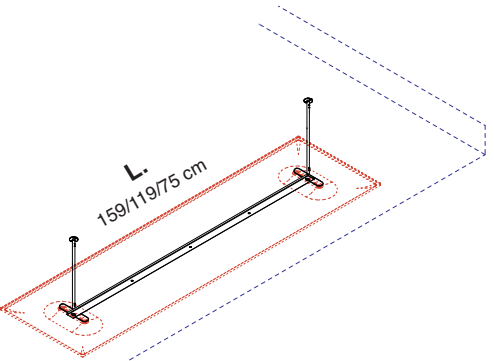
	Codice Code	Colore Colour	Prezzo Price	Descrizione Description
	<b>7MCF0316</b>	Cromato Chrome-plated Chromé Cromado Verchromt	<b>Per pannelli For panels L. 159 cm</b>	Kit per fissaggio a soffitto di un pannello Mitesco in posizione orizzontale composto da: 2 piastre a soffitto a 2 fori, 2 supporti (tubi) in acciaio cromato, 2 attacchi per pannello, 1 profilo livellatore.
	<b>7MCF0312</b>	Cromato Chrome-plated Chromé Cromado Verchromt	<b>Per pannelli For panels L. 119 cm</b>	Kit for the ceiling fixing of a Mitesco panel in horizontal position composed of: 2 ceiling plates with 2 holes, 2 supports (tubes) in chrome-plated steel, 2 hangings for the panel, 1 leveler profile.
	<b>7MCF0308</b>	Cromato Chrome-plated Chromé Cromado Verchromt	<b>Per pannelli For panels L. 75 cm</b>	Kit d'accrochage au plafond d'un panneau Mitesco en position horizontale composé de: 2 plaques pour plafond à 2 trous, 2 supports (tubes) en acier chromé, 2 accrochages pour panneau, 1 profil niveleur.
	<b>7MCF0416</b>	Cromato Chrome-plated Chromé Cromado Verchromt	<b>Per pannelli For panels L. 159 cm</b>	Kit per fissaggio a soffitto di un pannello Mitesco in posizione orizzontale composto da: 2 piastre a soffitto a 2 fori, 2 supporti (tubi) in acciaio cromato, 2 attacchi per pannello, 1 profilo livellatore.
	<b>7MCF0412</b>	Cromato Chrome-plated Chromé Cromado Verchromt	<b>Per pannelli For panels L. 119 cm</b>	Kit for the ceiling fixing of a Mitesco panel in horizontal position composed of: 2 ceiling plates with 2 holes, 2 supports (tubes) in chrome-plated steel, 2 hangings for the panel, 1 leveler profile.
	<b>7MCF0408</b>	Cromato Chrome-plated Chromé Cromado Verchromt	<b>Per pannelli For panels L. 75 cm</b>	Kit d'accrochage au plafond d'un panneau Mitesco en position horizontale composé de: 2 plaques pour plafond à 2 trous, 2 supports (tubes) en acier chromé, 2 accrochages pour panneau, 1 profil niveleur.
				
				



# MITESCO CEILING

design Michele De Lucchi  
Snowsound® technology by Caimi Brevetti

	Codice Code	Colore Colour	Prezzo Price	Descrizione Description
	7MCS1116	Cromato Chrome-plated Chromé Cromado Verchromt	<b>Per pannelli For panels L. 159 cm</b>	Kit per fissaggio a soffitto di un pannello Mitesco composto da: 2 piastre a soffitto a 2 fori, 2 supporti (tubi) in acciaio cromato, 2 attacchi per pannello con snodo per inclinazione del pannello, 1 profilo livellatore.
	7MCS1112	Cromato Chrome-plated Chromé Cromado Verchromt	<b>Per pannelli For panels L. 119 cm</b>	Kit for the ceiling fixing of a Mitesco panel composed of: 2 ceiling plates with 2 holes, 2 supports (tubes) in chrome-plated steel, 2 hangings with articulated joint for the inclination of the panel, 1 leveler profile.
	7MCS1108	Cromato Chrome-plated Chromé Cromado Verchromt	<b>Per pannelli For panels L. 75 cm</b>	Kit d'accrochage au plafond d'un panneau Mitesco composé de: 2 plaques pour plafond à 2 trous, 2 supports (tubes) en acier chromé, 2 accrochages pour panneau avec articulation pour l'inclinaison du panneau, 1 profil niveleur.
	7MCS1216	Cromato Chrome-plated Chromé Cromado Verchromt	<b>Per pannelli For panels L. 159 cm</b>	Kit per fissaggio a soffitto di un pannello Mitesco composto da: 2 piastre a soffitto a 2 fori, 2 supporti (tubi) in acciaio cromato, 2 attacchi per pannello con snodo per inclinazione del pannello, 1 profilo livellatore.
	7MCS1212	Cromato Chrome-plated Chromé Cromado Verchromt	<b>Per pannelli For panels L. 119 cm</b>	Kit for the ceiling fixing of a Mitesco panel composed of: 2 ceiling plates with 2 holes, 2 supports (tubes) in chrome-plated steel, 2 hangings with articulated joint for the inclination of the panel, 1 leveler profile.
	7MCS1208	Cromato Chrome-plated Chromé Cromado Verchromt	<b>Per pannelli For panels L. 75 cm</b>	Kit d'accrochage au plafond d'un panneau Mitesco composé de: 2 plaques pour plafond à 2 trous, 2 supports (tubes) en acier chromé, 2 accrochages pour panneau avec articulation pour l'inclinaison du panneau, 1 profil niveleur.
			<b>L. 159/119/75 cm</b>	Kit para el montaje al techo de 1 panel Mitesco compuesto por: 2 placas de techo con 2 huecos, 2 soportes (tubos) de acero cromado, 2 enganches con articulación para la inclinación del panel, 1 perfil nivelador.
				Set für die Deckenbefestigung eines Mitesco-Paneels, bestehend aus: 2 Deckenmontageplatten mit 2 Befestigungsbohrungen, 2 Halterungen (Rohre) aus verchromtem Stahl, 2 Paneelbefestigungen mit Gelenk zur Neigung des Paneels, 1 Justierungsprofil.



# MITESCO CEILING

design Michele De Lucchi  
Snowsound® technology by Caimi Brevetti

	Codice Code	Colore Colour	Prezzo Price	Descrizione Description
	<b>7MCS1316</b>	Cromato Chrome-plated Chromé Cromado Verchromt	<b>Per pannelli For panels L. 159 cm</b>	Kit per fissaggio a soffitto di un pannello Mitesco composto da: 2 piastre a soffitto a 2 fori, 2 supporti (tubi) in acciaio cromato, 2 attacchi per pannello con snodo per inclinazione del pannello, 1 profilo livellatore.
	<b>7MCS1312</b>	Cromato Chrome-plated Chromé Cromado Verchromt	<b>Per pannelli For panels L. 119 cm</b>	Kit for the ceiling fixing of a Mitesco panel composed of: 2 ceiling plates with 2 holes, 2 supports (tubes) in chrome-plated steel, 2 hangings with articulated joint for the inclination of the panel, 1 leveler profile.
	<b>7MCS1308</b>	Cromato Chrome-plated Chromé Cromado Verchromt	<b>Per pannelli For panels L. 75 cm</b>	Kit d'accrochage au plafond d'un panneau Mitesco composé de: 2 plaques pour plafond à 2 trous, 2 supports (tubes) en acier chromé, 2 accrochages pour panneau avec articulation pour l'inclinaison du panneau, 1 profil niveleur.
	<b>7MCS1416</b>	Cromato Chrome-plated Chromé Cromado Verchromt	<b>Per pannelli For panels L. 159 cm</b>	Kit per fissaggio a soffitto di un pannello Mitesco composto da: 2 piastre a soffitto a 2 fori, 2 supporti (tubi) in acciaio cromato, 2 attacchi per pannello con snodo per inclinazione del pannello, 1 profilo livellatore.
	<b>7MCS1412</b>	Cromato Chrome-plated Chromé Cromado Verchromt	<b>Per pannelli For panels L. 119 cm</b>	Kit for the ceiling fixing of a Mitesco panel composed of: 2 ceiling plates with 2 holes, 2 supports (tubes) in chrome-plated steel, 2 hangings with articulated joint for the inclination of the panel, 1 leveler profile.
	<b>7MCS1408</b>	Cromato Chrome-plated Chromé Cromado Verchromt	<b>Per pannelli For panels L. 75 cm</b>	Kit d'accrochage au plafond d'un panneau Mitesco composé de: 2 plaques pour plafond à 2 trous, 2 supports (tubes) en acier chromé, 2 accrochages pour panneau avec articulation pour l'inclinaison du panneau, 1 profil niveleur.
				Kit para el montaje al techo de 1 panel Mitesco compuesto por: 2 placas de techo con 2 huecos, 2 soportes (tubos) de acero cromado, 2 enganches con articulación para la inclinación del panel, 1 perfil nivelador.
				Set für die Deckenbefestigung eines Mitesco-Paneels, bestehend aus: 2 Deckenmontageplatten mit 2 Befestigungsbohrungen, 2 Halterungen (Rohre) aus verchromtem Stahl, 2 Paneelbefestigungen mit Gelenk zur Neigung des Paneels, 1 Justierprofil.

# MITESCO FRAME

design Michele De Lucchi  
Snowsound® technology by Caimi Brevetti

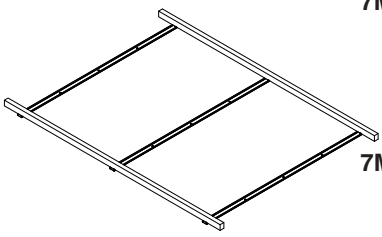
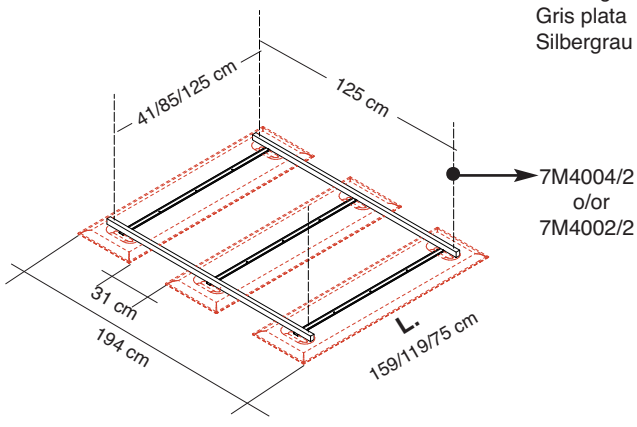
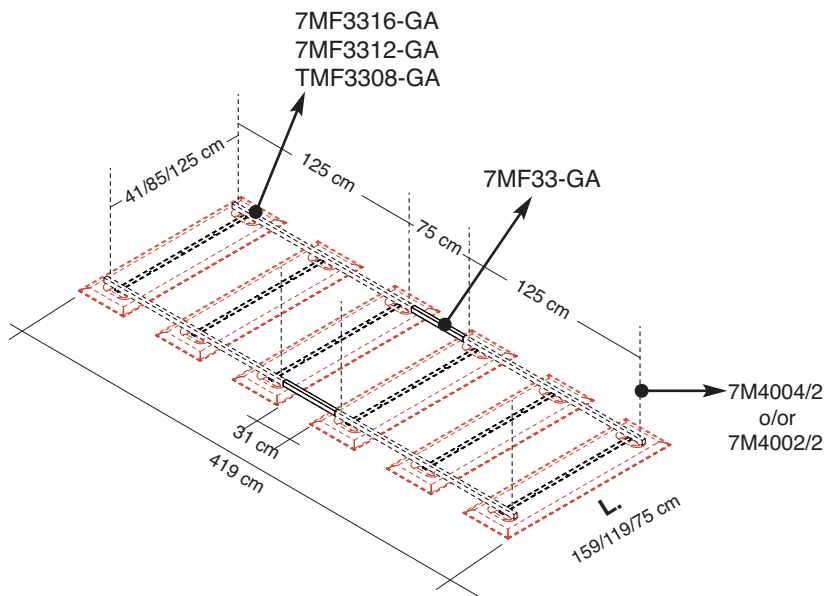
	Codice Code	Colore Colour	Prezzo Price	Descrizione Description
	<b>7MF3316-GA</b>	Grigio argento Silver grey Gris argenté Gris plata Silbergrau	<b>Per pannelli For panels L. 159 cm</b>	Telaio in acciaio verniciato con polveri epossidiche completo di 3 profili livellatori per appendimento a soffitto di 3 pannelli Mitesco
	<b>7MF3312-GA</b>	Grigio argento Silver grey Gris argenté Gris plata Silbergrau		Cadre en acier peint en époxy avec 3 profils niveleurs pour accrochage au plafond de 3 panneaux Mitesco.
	<b>7MF3308-GA</b>	Grigio argento Silver grey Gris argenté Gris plata Silbergrau		Bastidor de acero recubierto epoxi completos de 3 perfiles niveladores para fijación al techo de 3 paneles Mitesco
				Rahmen aus pulverbeschichtetem Stahl für die Deckenaufhängung von 3 Mitesco-Paneelen, inklusive 3 Justierungsprofilen.
	<b>7MF33-GA</b>	Grigio argento Silver grey Gris argenté Gris plata Silbergrau	<b>1 coppia / 1 pair 1 paire / 1 pare 1 Paar</b>	Coppia giunti distanziali in acciaio verniciato con polveri epossidiche per telai da 3 pannelli cod. 7MF3316-GA / 7MF3312-GA / 7MF3308-GA  Pair of spacer joints in powder coated steel for 3 panels frame code 7MF3316-GA / 7MF3312-GA / 7MF3308-GA.  Paire de joints espaceurs en acier peint en époxy pour cadres à 3 panneaux, réf. 7MF3316-GA / 7MF3312-GA / 7MF3308-GA.  Par de juntas espaciadoras de acero recubierto epoxi para bastidores de 3 paneles cod.7MF3316-GA / 7MF3312-GA / 7MF3308-GA.  1 Paar Abstandhalter aus pulverbeschichtetem Stahl für Rahmen zur Abhängung von 3 Paneelen, Art. Nr. 7MF3316-GA / 7MF3312-GA / 7MF3308-GA.
				

# MITESCO FRAME

design Michele De Lucchi  
Snowsound® technology by Caimi Brevetti

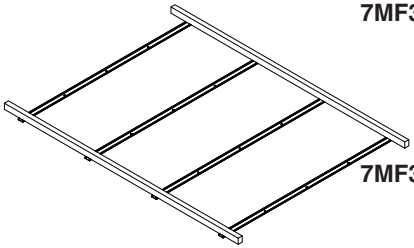
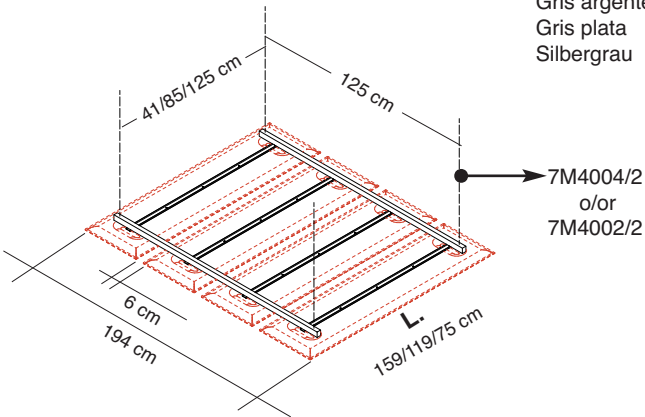
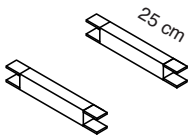
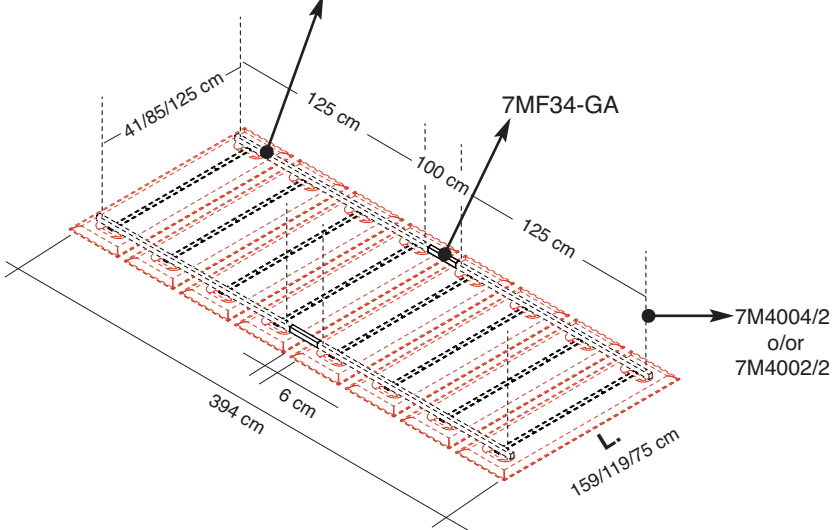
	Codice Code	Colore Colour	Prezzo Price	Descrizione Description
	<b>7MF3416-GA</b>	Grigio argento Silver grey Gris argenté Gris plata Silbergrau	<b>Per pannelli For panels L. 159 cm</b>	Telaio in acciaio verniciato con polveri epossidiche completo di 4 profili livellatori per appendimento a soffitto di 4 pannelli Mitesco
	<b>7MF3412-GA</b>	Grigio argento Silver grey Gris argenté Gris plata Silbergrau		Cadre en acier peint en époxy avec 4 profils niveleurs pour accrochage au plafond de 4 panneaux Mitesco.
	<b>7MF3408-GA</b>	Grigio argento Silver grey Gris argenté Gris plata Silbergrau		Bastidor de acero recubierto epoxi completos de 4 perfiles niveladores para fijación al techo de 4 paneles Mitesco
				Rahmen aus pulverbeschichtetem Stahl für die Deckenaufhängung von 4 Mitesco-Paneeelen, inklusive 4 Justierungsprofilen.
	<b>7MF34-GA</b>	Grigio argento Silver grey Gris argenté Gris plata Silbergrau	<b>1 coppia / 1 pair 1 paire / 1 pare 1 Paar</b>	Coppia giunti distanziali in acciaio verniciato con polveri epossidiche per telai da 4 pannelli cod. 7MF3416-GA / 7MF3412-GA / 7MF3408-GA
				Paire de joints espaceurs en acier peint en époxy pour cadres à 4 panneau, réf. 7MF3416-GA / 7MF3412-GA / 7MF3408-GA.
				1 Paar Abstandhalter aus pulverbeschichtetem Stahl für Rahmen zur Abhängung von 4 Paneelen, Art. Nr. 7MF3416-GA / 7MF3412-GA / 7MF3408-GA.

# MITESCO FRAME

design Michele De Lucchi  
Snowsound® technology by Caimi Brevetti

	Codice Code	Colore Colour	Prezzo Price	Descrizione Description
<p>ø 0,8 cm</p> <p>L max 400 cm</p> <p>Per M6 (non inclusa) For M6 (not included)</p>	<b>7M4004/2</b>	Cromato Chrome-plated Chromé Cromado Verchromt		<p>Kit per fissaggio a soffitto del telaio 7MF3316-GA / 7MF3312-GA / 7MF3308-GA e 7MF3416-GA / 7MF3412-GA / 7MF3408-GA composto da: 4 attacchi a soffitto filettati M6 - 4 cavi in acciaio - 4 attacchi per telaio.</p> <p>Kit for the ceiling fixing of frame 7MF3316-GA / 7MF3312-GA / 7MF3308-GA and 7MF3416-GA / 7MF3412-GA / 7MF3408-GA composed of: 4 ceiling hanging threaded M6, 4 steel cables, 4 hangings for frame.</p> <p>Kit d'accrochage au plafond du cadre 7MF3316-GA / 7MF3312-GA / 7MF3308-GA et 7MF3416-GA / 7MF3412-GA / 7MF3408-GA composé de: 4 accrochages au plafond filetés M6 – 4 câbles en acier – 4 accrochages pour cadre</p> <p>Kit para el montaje al techo del bastidor 7MF3316-GA / 7MF3312-GA / 7MF3308-GA y 7MF3416-GA / 7MF3412-GA / 7MF3408-GA compuesto por: 4 enganches al techo roscados M6 – 4 cables de acero - 4 enganches para bastidor.</p> <p>Set für die Deckenbefestigung des Rahmens 7MF3316-GA / 7MF3312-GA / 7MF3308-GA und 7MF3416-GA / 7MF3412-GA / 7MF3408-GA bestehend aus: 4 Deckenbefestigungen für Gewinde M6, 4 Stahlseile, 4 Befestigungen für den Rahmen.</p>
<p>ø 4 cm</p> <p>L max 400 cm</p>	<b>7M4002/2</b>	Cromato Chrome-plated Chromé Cromado Verchromt		<p>Kit per fissaggio a soffitto del telaio 7MF3316-GA / 7MF3312-GA / 7MF3308-GA e 7MF3416-GA / 7MF3412-GA / 7MF3408-GA composto da: 4 piastre a soffitto a 2 fori - 4 cavi in acciaio - 4 attacchi per telaio.</p> <p>Kit for the ceiling fixing of frame 7MF3316-GA / 7MF3312-GA / 7MF3308-GA and 7MF3416-GA / 7MF3412-GA / 7MF3408-GA composed of: 4 ceiling plates with 2 holes, 4 steel cables, 4 hangings for frame.</p> <p>Kit d'accrochage au plafond du cadre 7MF3316-GA / 7MF3312-GA / 7MF3308-GA et 7MF3416-GA / 7MF3412-GA / 7MF3408-GA composé de: 4 plaques pour plafond à 2 trous – 4 câbles en acier – 4 accrochages pour cadre</p> <p>Kit para el montaje al techo del bastidor 7MF3316-GA / 7MF3312-GA / 7MF3308-GA y 7MF3416-GA / 7MF3412-GA / 7MF3408-GA compuesto por: 4 placas de techo con 2 huecos – 4 cables de acero - 4 enganches para bastidor.</p> <p>Set für die Deckenbefestigung des Rahmens 7MF3316-GA / 7MF3312-GA / 7MF3308-GA und 7MF3416-GA / 7MF3412-GA / 7MF3408-GA bestehend aus: 4 Deckenmontageplatten mit 2 Befestigungsbohrungen, 4 Stahlseile, 4 Befestigungen für den Rahmen.</p>

# MITESCO FRAME

design Michele De Lucchi  
Snowsound® technology by Caimi Brevetti



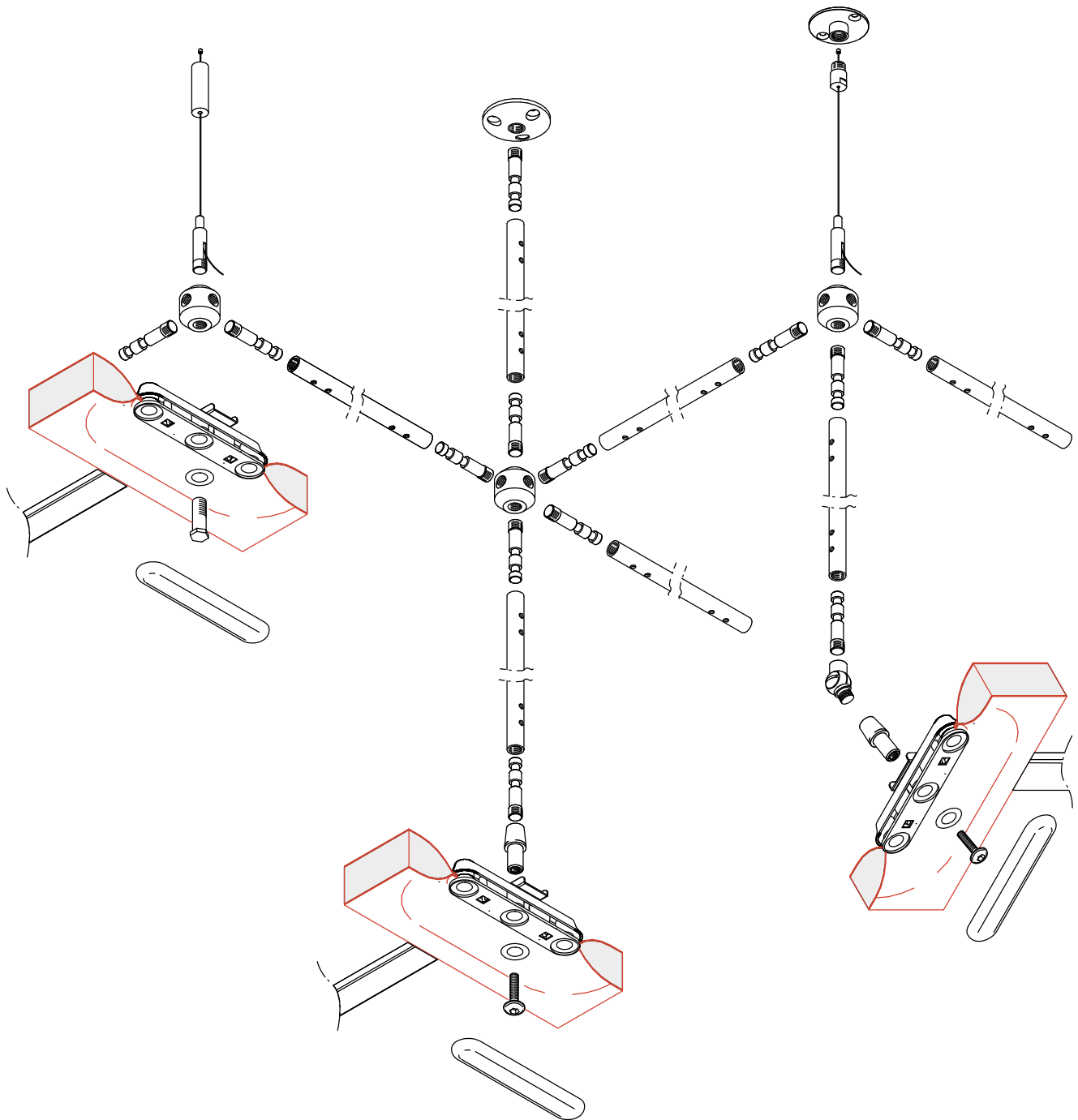

**Esempio di struttura reticolare per l'appendimento a soffitto dei pannelli Mitesco.  
Per strutture complesse rivolgersi all'ufficio tecnico (e-mail: [project.dept@caimi.com](mailto:project.dept@caimi.com))**

**Example of a reticular structure for the ceiling hanging of Mitesco panels.  
For complex structures contact the Caimi export department (e-mail: [export.dept@caimi.com](mailto:export.dept@caimi.com))**

**Exemple de structure réticulaire pour l'accrochage au plafond des panneaux Mitesco.  
Dans le cas de structures complexes, s'adresser au bureau export (e-mail: [export.dept@caimi.com](mailto:export.dept@caimi.com))**

**Ejemplo de estructura reticular para el enganche al techo de paneles Mitesco.  
Para estructuras mas complejas contactar el departamento export (e-mail: [export.dept@caimi.com](mailto:export.dept@caimi.com))**

**Beispiel für die Deckenaufhängung der Mitesco-Paneele in einer netzartigen Struktur.  
Für komplexe Strukturen wenden Sie sich bitte an unsere Exportabteilung  
(E-Mail: [export.dept@caimi.com](mailto:export.dept@caimi.com))**



# MITESCO NET

design Michele De Lucchi  
Snowsound® technology by Caimi Brevetti

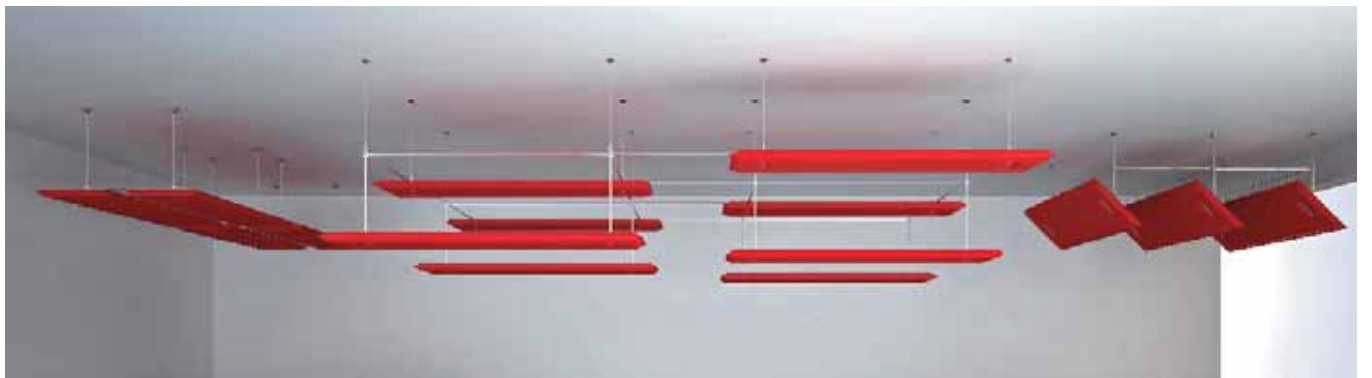
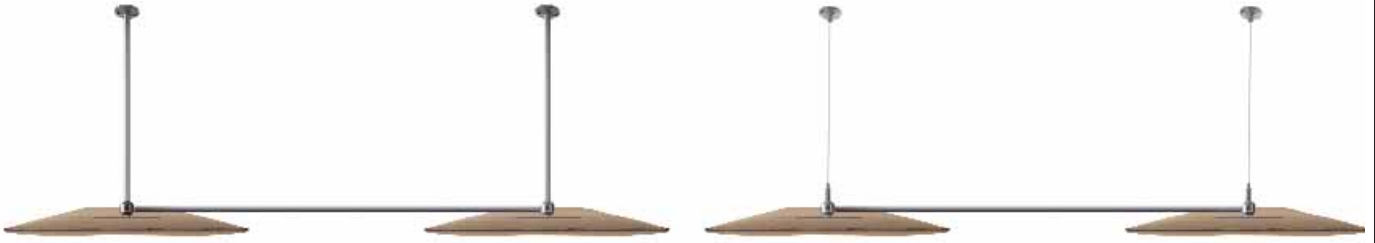

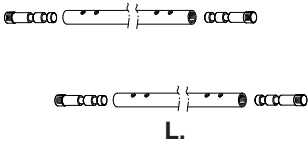
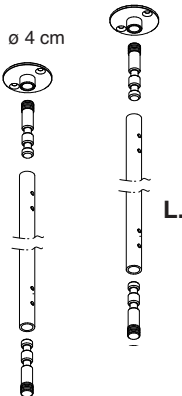
	Codice Code	Colore Colour	Prezzo Price	Descrizione Description
	7M420	Cromato Chrome-plated Chromé Cromado Verchromt	L. 20 cm	Coppia tubi in acciaio cromato disponibili in 8 lunghezze per la realizzazione di strutture reticolari per l'appendimento a soffitto dei pannelli Mitesco. I tubi vengono utilizzati orizzontalmente o verticalmente per scendere al secondo livello. Si collegano tra di loro utilizzando i giunti a 6 vie cod 7M406.
	7M437	Cromato Chrome-plated Chromé Cromado Verchromt	L. 37 cm	Pair of tubes in chrome-plated steel available in 8 lengths for the realisation of reticular structures for the ceiling hanging of Mitesco panels. The tubes are used horizontally or vertically to go down to the second level. They connect to each other by using the 6 ways joints code 7M406
	7M438	Cromato Chrome-plated Chromé Cromado Verchromt	L. 38 cm	Paire de tubes en acier chromé disponibles dans 8 longueurs pour réaliser des structures réticulaires pour l'accrochage au plafond des panneaux Mitesco. Les tubes sont utilisés horizontalement ou verticalement afin de descendre au deuxième niveau. Ils sont connectés entre eux à l'aide des joints à 6 voies réf. 7M406.
	7M447	Cromato Chrome-plated Chromé Cromado Verchromt	L. 47 cm	Par de tubos de acero cromado disponibles en 8 longitudes para la realizacion de estructuras reticulares para el enganche al techo de paneles Mitesco. Los tubos pueden ser utilizados horizontalmente o verticalmente para bajar al segundo nivel. Se conectan el uno al otro mediante la articulación a 6 vias cod 7M406.
	7M472	Cromato Chrome-plated Chromé Cromado Verchromt	L. 72 cm	1 Paar verchromte Stahlrohre verfügbar in 8 verschiedenen Längen für die Umsetzung der Deckenaufhängung von Mitesco-Paneeelen in einer netzartigen Struktur. Die Rohre werden entweder horizontal oder auch vertikal verwendet, um zwei Ebenen zu schaffen. Die Rohre werden durch den 6-Weg-Verbinder Art.Nr. 7M406 miteinander verbunden.
	7M482	Cromato Chrome-plated Chromé Cromado Verchromt	L. 82 cm	
	7M4112	Cromato Chrome-plated Chromé Cromado Verchromt	L. 112 cm	
	7M4122	Cromato Chrome-plated Chromé Cromado Verchromt	L. 122 cm	
	7M4020	Cromato Chrome-plated Chromé Cromado Verchromt	L. 20	Kit per fissaggio a soffitto della struttura reticolare composto da: 2 piastre a soffitto a 2 fori - 2 supporti (tubi) in acciaio cromato - 2 attacchi per giunti a 6 vie (7M406).
	7M4047	Cromato Chrome-plated Chromé Cromado Verchromt	L. 47	Kit for the ceiling fixing of the reticular structure composed of: 2 ceiling plates with 2 holes - 2 supports (tubes) in chrome-plated steel - 2 hangings for 6-ways joints (7M406).
	7M4082	Cromato Chrome-plated Chromé Cromado Verchromt	L. 82	Kit para el montaje al techo de la estructura reticular compuesto por: 2 placas de techo con 2 huecos - 2 soportes (tubos) de acero cromado - 2 enganches para articulaciones a 6 vias (7M406).
	7M40122	Cromato Chrome-plated Chromé Cromado Verchromt	L. 122	Set für die Deckenbefestigung der netzartigen Struktur, bestehend aus: 2 Deckenmontageplatten mit 2 Befestigungsbohrungen, 2 Halterungen (Rohre) aus verchromtem Stahl, 2 Befestigungen für d. 6-Weg-Verbinder (7M406).

# MITESCO NET

design Michele De Lucchi  
Snowsound® technology by Caimi Brevetti

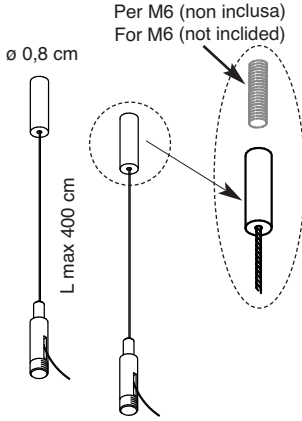
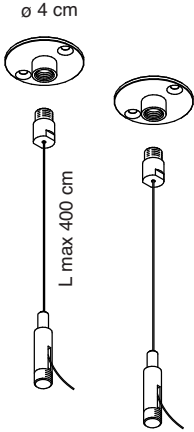
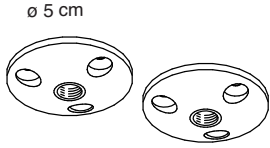
	Codice Code	Colore Colour	Prezzo Price	Descrizione Description
	<p><b>7M404</b></p>	<p>Cromato Chrome-plated Chromé Cromado Verchromt</p>		<p>Kit per fissaggio a soffitto della struttura reticolare composto da: 2 attacchi a soffitto filettati M6 - 2 cavi in acciaio - 2 attacchi per giunti a 6 vie (7M406).</p> <p>Kit for the ceiling fixing of the reticular structure composed of: 2 ceiling hanging threaded M6 - 2 steel cables - 2 hangings for 6-ways joints (7M406).</p> <p>Kit d'accrochage au plafond de la structure réticulaire composé de: 2 accrochages au plafond filetés M6 - 2 câbles en acier - 2 accrochages pour joints à 6 voies (7M406).</p> <p>Kit para el montaje al techo de la estructura reticular compuesto por: 2 enganches al techo roscados M6 - 2 cables de acero, 2 enganches para articulaciones a 6 vías (7M406).</p> <p>Set für die Deckenbefestigung der netzartigen Struktur, bestehend aus: 2 Deckenbefestigungen für Gewinde M6, 2 Stahlseile, 2 Befestigungen für d. 6-Weg-Verbinder (7M406).</p>
	<p><b>7M4002</b></p>	<p>Cromato Chrome-plated Chromé Cromado Verchromt</p>		<p>Kit per fissaggio a soffitto della struttura reticolare composto da: 2 piastre a soffitto a 2 fori - 2 cavi in acciaio - 2 attacchi per giunti a 6 vie (7M406).</p> <p>Kit for the ceiling fixing of the reticular structure composed of: 2 ceiling plates with 2 holes - 2 steel cables - 2 hangings for 6-ways joints (7M406).</p> <p>Kit d'accrochage au plafond de la structure réticulaire composé de: 2 plaques pour plafond à 2 trous - 2 câbles en acier - 2 accrochages pour joints à 6 voies (7M406).</p> <p>Kit para el montaje al techo de la estructura reticular compuesto por: 2 placas de techo con 2 huecos - 2 cables de acero, 2 enganches para articulaciones a 6 vías (7M406).</p> <p>Set für die Deckenbefestigung der netzartigen Struktur, bestehend aus: 2 Deckenmontageplatten mit 2 Befestigungsbohrungen, 2 Stahlseile, 2 Befestigungen für d. 6-Weg-Verbinder (7M406).</p>
	<p><b>7M403</b> <b>OPZIONALE</b> <b>OPTIONAL</b></p>	<p>Cromato Chrome-plated Chromé Cromado Verchromt</p>		<p>Coppia piastre a soffitto a 3 fori. Possono essere acquistate separatamente e utilizzati per sostituire gli attacchi a 2 fori in tutti i kit di fissaggio a soffitto. ARTICOLO OPZIONALE.</p> <p>Pair of ceiling plates with 3 holes. Can be purchased separately and be used to replace the plates with 2 holes in all ceiling hanging kits. OPTIONAL ITEM.</p> <p>Paire de plaques pour plafond à 3 trous. Il est possible de les acheter séparément et les utiliser pour remplacer les accroches à 2 trous dans tous les kits d'accrochage au plafond. ARTICLE OPTIONNEL</p> <p>Par de placas de techo con 3 huecos. Se pueden comprar separatamente y ser utilizadas para reemplazar los enganches a 2 huecos en todos los kit de montaje al techo. ARTÍCULO OPCIONAL</p> <p>2 Deckenmontageplatten mit 3 Befestigungsbohrungen. Diese können separat gekauft und an Stelle der Befestigungen mit 2 Bohrungen in allen Deckenbefestigungs-Sets verwendet werden. ERHALTLICH</p>

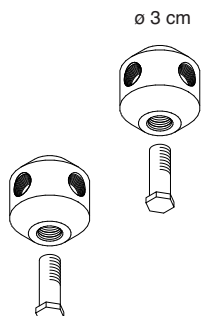
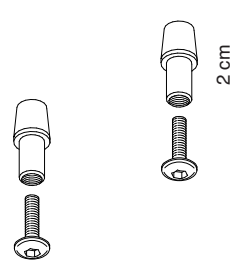
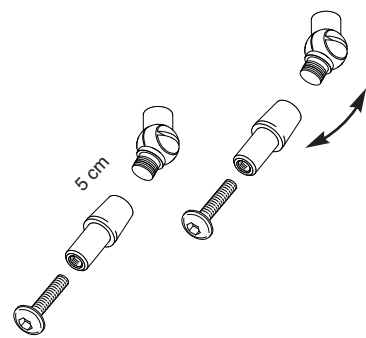
	Codice Code	Colore Colour	Prezzo Price	Descrizione Description
 <p>ø 3 cm</p>	<p><b>7M406</b></p>	<p>Cromato Chrome-plated Chromé Cromado Verchromt</p>	<p>1 coppia / 1 pair 1 paire / 1 pare 1 Paar</p>	<p>Coppia giunti a 6 vie per collegamento dei tubi cod. 7M420 / 7M437 / 7M438 / 7M447 / 7M472 / 7M482 / 7M4112 / 7M4122 per la realizzazione di strutture reticolari. Il pannello può essere fissato direttamente al giunto utilizzando le viti in dotazione.</p> <p>Pair of 6 ways joints for connection of the tubes code 7M420 / 7M437 / 7M438 / 7M447 / 7M472 / 7M482 / 7M4112 / 7M4122 for the realization of reticular structures. The panel can be fixed directly to the joint by using the provided screws.</p> <p>Paire de joints à 6 voies pour l'accrochage des tubes réf. 7M420 / 7M437 / 7M438 / 7M447 / 7M472 / 7M482 / 7M4112 / 7M4122 pour la réalisation de structures réticulaires. On peut fixer le panneau directement au joint par les vis incluses.</p> <p>Par de articulaciones a 6 vias para la connexion de tubos cod. 7M420 / 7M437 / 7M438 / 7M447 / 7M472 / 7M482 / 7M4112 / 7M4122 para la realización de estructuras reticulares. El panel puede ser enganchado directamente a la articulación utilizando los tornillos suministrados.</p> <p>1 Paar 6-Weg-Verbinder für die Verbindung der Rohre Art. Nr. 7M420 / 7M437 / 7M438 / 7M447 / 7M472 / 7M482 / 7M4112 / 7M4122 zur Umsetzung netzartiger Strukturen. Das Paneel kann durch die Verwendung der beiliegenden Schrauben direkt an dem Verbindungsstück befestigt werden.</p>
 <p>2 cm</p>	<p><b>7M407</b></p>	<p>Cromato Chrome-plated Chromé Cromado Verchromt</p>		<p>Coppia adapter per collegamento del pannello ai tubi cod. 7M420 / 7M437 / 7M438 / 7M447 / 7M472 / 7M482 / 7M4112 / 7M4122 da utilizzare in assenza di giunto a 6 vie (7M406).</p> <p>Pair of adapters for the connection of the panel to the tubes code 7M420 / 7M437 / 7M438 / 7M447 / 7M472 / 7M482 / 7M4112 / 7M4122 to be used in absence of the 6 ways joint (7M406).</p> <p>Paire d'adaptateurs pour l'accrochage du panneau aux tubes réf. 7M420 / 7M437 / 7M438 / 7M447 / 7M472 / 7M482 / 7M4112 / 7M4122 à utiliser au cas d'absence du joint à 6 voies (7M406).</p> <p>Par de adaptadores para la conexión del panel a los tubos cod. 7M420 / 7M437 / 7M438 / 7M447 / 7M472 / 7M482 / 7M4112 / 7M4122 utilizar en ausencia de la articulación a 6 vias (7M406).</p> <p>1 Paar Adapter für die Verbindung der Paneele mit den Rohren Art. Nr. 7M420 / 7M437 / 7M438 / 7M447 / 7M472 / 7M482 / 7M4112 / 7M4122, zu benutzen wenn nicht der 6-Weg-Verbinder (7M406) verwendet wird.</p>
 <p>5 cm</p>	<p><b>7M4005</b></p>	<p>Cromato Chrome-plated Chromé Cromado Verchromt</p>		<p>Coppia snodi per collegamento del pannello ai tubi cod. 7M420 / 7M437 / 7M438 / 7M447 / 7M472 / 7M482 / 7M4112 / 7M4122. Da utilizzare in assenza di giunto a 6 vie (7M406) per dare l'inclinazione desiderata al pannello.</p> <p>Pair of articulated joints for the connection of the panel to the tubes code 7M420 / 7M437 / 7M438 / 7M447 / 7M472 / 7M482 / 7M4112 / 7M4122. To be used in absence of the 6 ways joint (7M406) to give the desired inclination to the panel.</p> <p>Paire d'articulations pour l'accrochage du panneau aux tubes réf. 7M420 / 7M437 / 7M438 / 7M447 / 7M472 / 7M482 / 7M4112 / 7M4122. A utiliser au cas d'absence de joints à 6 voies (7M406) pour donner au panneau l'inclinaison souhaitée.</p> <p>Par de articulaciones móviles para la conexión del panel a los tubos cod. 7M420 / 7M437 / 7M438 / 7M447 / 7M472 / 7M482 / 7M4112 / 7M4122. Utilizar en ausencia de la articulación a 6 vias (7M406) para dar la inclinación deseada al panel.</p> <p>1 Paar Gelenke für die Verbindung der Paneele mit den Rohren Art. Nr. 7M420 / 7M437 / 7M438 / 7M447 / 7M472 / 7M482 / 7M4112 / 7M4122. Zu benutzen, um dem Paneel den gewünschten Neigungswinkel zu geben, wenn nicht der 6-Weg-Verbinder (7M406) verwendet wird.</p>

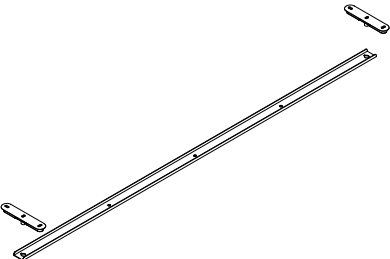
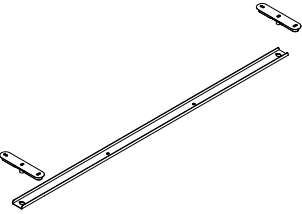
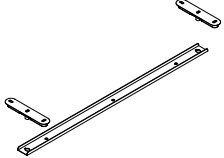
	Codice Code	Colore Colour	Prezzo Price	Descrizione Description
	<p><b>7M160-GA</b></p>	<p>Grigio argento Silver grey Gris argenté Gris plata Silbergrau</p>	<p><b>Per pannelli For panels L. 159 cm</b></p>	<p>Profilo livellatore in acciaio verniciato con polveri epossidiche e tecnopolimero per 1 pannello Mitesco: 7M1016-XXXX, 7M1016BO-XXXX (XXXX = Variante colore). Utilizzare sempre in caso di fissaggio del pannello al soffitto in posizione orizzontale (parallela al piano).</p> <p>Leveler profile in powder coated steel and high-tech polymer for 1 Mitesco panel code: 7M1016-XXXX, 7M1016BO-XXXX (XXXX = colour option). To be always used in case of fixation of the panel to the ceiling in horizontal position (parallel to the floor).</p> <p>Profil niveleur en acier peint en époxy et technopolymère pour un panneau Mitesco: 7M1016-XXXX, 7M1016BO-XXXX (XXXX = option couleur). Toujours à prévoir en cas d'accrochage du panneau au plafond en position horizontale (parallèle à la surface).</p> <p>Perfil nivelador de acero recubierto epoxi y polímero para 1 panel Mitesco cod. 7M1016-XXXX, 7M1016BO-XXXX (XXXX = opción color). Utilizar siempre en caso de enganche del panel al techo en posición horizontal (paralelo al plano).</p> <p>Justierungsprofil aus pulverbeschichtetem Stahl und Technopolymer für 1 Mitesco-Paneel Art.-Nr. 7M1016-XXXX, 7M1016BO-XXXX (XXXX = Farbvariante). Immer verwenden wenn das Paneel in horizontaler Position an der Decke befestigt wird. (Parallel zur Ebene).</p>
	<p><b>7M120-GA</b></p>	<p>Grigio argento Silver grey Gris argenté Gris plata Silbergrau</p>	<p><b>Per pannelli For panels L. 119 cm</b></p>	<p>Profilo livellatore in acciaio verniciato con polveri epossidiche e tecnopolimero per 1 pannello Mitesco: 7M1012-XXXX, 7M1012BO-XXXX (XXXX = Variante colore). Utilizzare sempre in caso di fissaggio del pannello al soffitto in posizione orizzontale (parallela al piano).</p> <p>Leveler profile in powder coated steel and high-tech polymer for 1 Mitesco panel code: 7M1012-XXXX, 7M1012BO-XXXX (XXXX = colour option). To be always used in case of fixation of the panel to the ceiling in horizontal position (parallel to the floor).</p> <p>Profil niveleur en acier peint en époxy et technopolymère pour un panneau Mitesco: 7M1012-XXXX, 7M1012BO-XXXX (XXXX = option couleur). Toujours à prévoir en cas d'accrochage du panneau au plafond en position horizontale (parallèle à la surface).</p> <p>Perfil nivelador de acero recubierto epoxi y polímero para 1 panel Mitesco cod. 7M1012-XXXX, 7M1012BO-XXXX (XXXX = opción color). Utilizar siempre en caso de enganche del panel al techo en posición horizontal (paralelo al plano).</p> <p>Justierungsprofil aus pulverbeschichtetem Stahl und Technopolymer für 1 Mitesco-Paneel Art.-Nr. 7M1012-XXXX, 7M1012BO-XXXX (XXXX = Farbvariante). Immer verwenden wenn das Paneel in horizontaler Position an der Decke befestigt wird. (Parallel zur Ebene).</p>
	<p><b>7M80-GA</b></p>	<p>Grigio argento Silver grey Gris argenté Gris plata Silbergrau</p>	<p><b>Per pannelli For panels L. 75 cm</b></p>	<p>Profilo livellatore in acciaio verniciato con polveri epossidiche e tecnopolimero per 1 pannello Mitesco: 7M1008-XXXX, 7M1008BO-XXXX (XXXX = Variante colore). Utilizzare sempre in caso di fissaggio del pannello al soffitto in posizione orizzontale (parallela al piano).</p> <p>Leveler profile in powder coated steel and high-tech polymer for 1 Mitesco panel code: 7M1008-XXXX, 7M1008BO-XXXX (XXXX = colour option). To be always used in case of fixation of the panel to the ceiling in horizontal position (parallel to the floor).</p> <p>Profil niveleur en acier peint en époxy et technopolymère pour un panneau Mitesco: 7M1008-XXXX, 7M1008BO-XXXX (XXXX = option couleur). Toujours à prévoir en cas d'accrochage du panneau au plafond en position horizontale (parallèle à la surface).</p> <p>Perfil nivelador de acero recubierto epoxi y polímero para 1 panel Mitesco cod. 7M1008-XXXX, 7M1008BO-XXXX (XXXX = opción color). Utilizar siempre en caso de enganche del panel al techo en posición horizontal (paralelo al plano).</p> <p>Justierungsprofil aus pulverbeschichtetem Stahl und Technopolymer für 1 Mitesco-Paneel Art.-Nr. 7M1008-XXXX, 7M1008BO-XXXX (XXXX = Farbvariante). Immer verwenden wenn das Paneel in horizontaler Position an der Decke befestigt wird. (Parallel zur Ebene).</p>

# MITESCO DESK

design Michele De Lucchi  
Snowsound® technology by Caimi Brevetti

PER APPLICAZIONI A SCRIVANIA - DESK MOUNTING - MONTAGE SUR LE BUREAU -  
MONTAJE SOBRE MESAS DE ESCRITORIO - TISCHBEFESTIGUNG

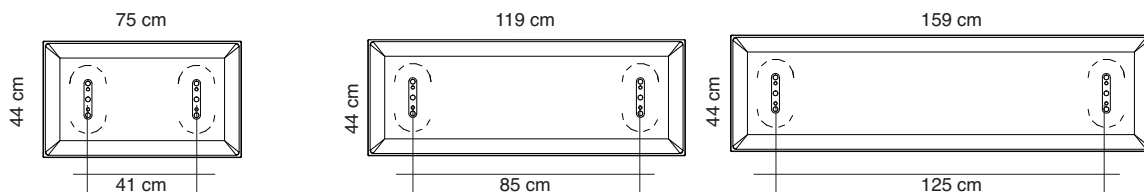

	Codice/Code Prezzo/Price	Codice/Code Prezzo/Price	Codice/Code Prezzo/Price
Bianco White Blanc <b>0001</b>	<b>7M084-0001</b>	<b>7M124-0001</b>	<b>7M164-0001</b>
Grigio argento Silver grey Gris argenté <b>8004</b>	<b>7M084-8004</b>	<b>7M124-8004</b>	<b>7M164-8004</b>
Grigio scuro Dark grey Gris foncé <b>8007</b>	<b>7M084-8007</b>	<b>7M124-8007</b>	<b>7M164-8007</b>
Beige Beige Beige <b>1008</b>	<b>7M084-1008</b>	<b>7M124-1008</b>	<b>7M164-1008</b>
Tortora Dove-grey Taupe <b>2005</b>	<b>7M084-2005</b>	<b>7M124-2005</b>	<b>7M164-2005</b>
Giallo Yellow Jaune <b>3008</b>	<b>7M084-3008</b>	<b>7M124-3008</b>	<b>7M164-3008</b>
Arancione Orange Orange <b>4030</b>	<b>7M084-4030</b>	<b>7M124-4030</b>	<b>7M164-4030</b>
Rosso Red Rouge <b>4027</b>	<b>7M084-4027</b>	<b>7M124-4027</b>	<b>7M164-4027</b>
Verde chiaro Light green Vert clair <b>7004</b>	<b>7M084-7004</b>	<b>7M124-7004</b>	<b>7M164-7004</b>
Verde Green Vert <b>7013</b>	<b>7M084-7013</b>	<b>7M124-7013</b>	<b>7M164-7013</b>
Blu Blue Bleu <b>6071</b>	<b>7M084-6071</b>	<b>7M124-6071</b>	<b>7M164-6071</b>
Nero Black Noir <b>8033</b>	<b>7M084-8033</b>	<b>7M124-8033</b>	<b>7M164-8033</b>



# MITESCO DESK

design Michele De Lucchi  
Snowsound® technology by Caimi Brevetti

Codice Code	Colore Colour	Prezzo Price	Descrizione Description
<b>7M511-GA</b>	Grigio argento Silver grey Gris argenté Gris plata Silbergrau	<b>1 coppia / 1 pair</b> <b>1 paire / 1 pare</b> <b>1 Paar</b>	Coppia staffe in acciaio verniciato con polveri epossidiche per fissaggio sopra il piano della scrivania tramite viti (non incluse). Attacchi al pannello Mitesco e coperture in tecnopolimero grigio o bianco. <b>Per pannelli Mitesco Desk pag. 56.</b>
<b>7M511-BO</b>	Bianco opaco Mat white Blanc mat Blanco mate Mattweiß	<b>1 coppia / 1 pair</b> <b>1 paire / 1 pare</b> <b>1 Paar</b>	Paire d'étriers en acier peint époxy pour fixation sur le bureau par des vis (pas incluses). Jonctions au panneau Mitesco et couvertures en technopolymère gris ou blanc. <b>Pour Mitesco Desk panneaux page 56.</b>
			Par de abrazaderas de acero recubierto epoxi para fijación sobre el plan del escritorio por medio de tornillos (no incluydos). Enganches al panel Mitesco y coberturas de polímero gris o blanco. <b>Para Mitesco Desk panels pag. 56.</b>
			1 Paar Halterungen aus pulverbeschichtetem Stahl zur Befestigung auf der Tischplatte durch Schrauben (nicht inkludiert). Mitesco-Panelbefestigungen und Abdeckungen aus grauem oder weissem Technopolymer. <b>Für Mitesco Desk Paneele, Seite 56.</b>

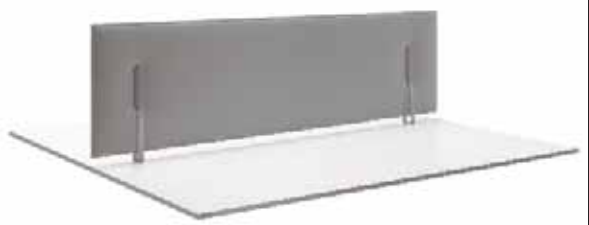
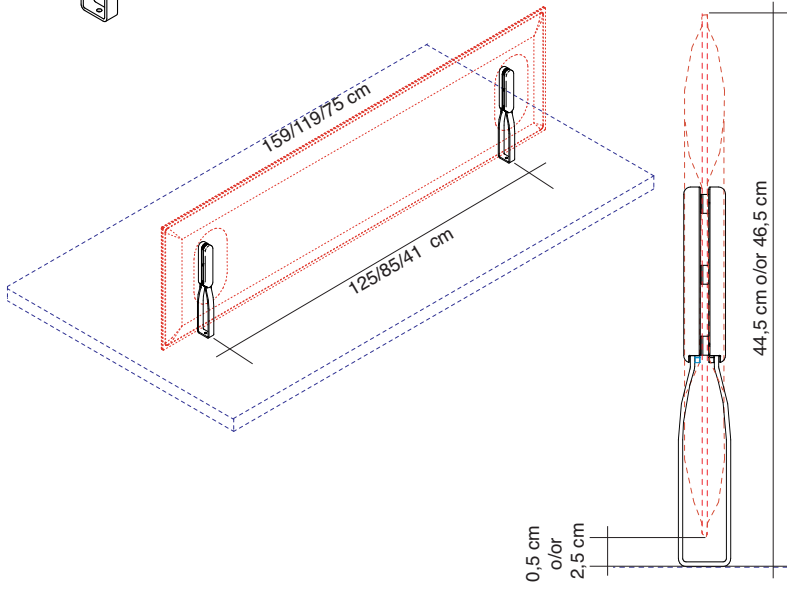
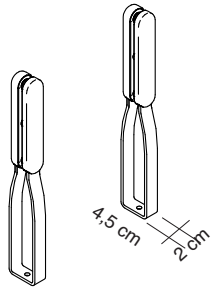

<b>7S100-GA</b>	Grigio argento Silver grey Gris argenté Gris plata Silbergrau	<b>1 coppia / 1 pair</b> <b>1 paire / 1 pare</b> <b>1 Paar</b>	Da utilizzare con staffe 7M511-GA / 7M511-BO. To be used with brackets 7M511-GA / 7M511-BO. Utiliser avec étriers 7M511-GA / 7M511-BO.
<b>7S100-BO</b>	Bianco opaco Mat white Blanc mat Blanco mate Mattweiß	<b>1 coppia / 1 pair</b> <b>1 paire / 1 pare</b> <b>1 Paar</b>	Utilización con abrazaderas 7M511-GA / 7M511-BO. Zur Verwendung mit den Halterungen 7M511-GA / 7M511-BO.

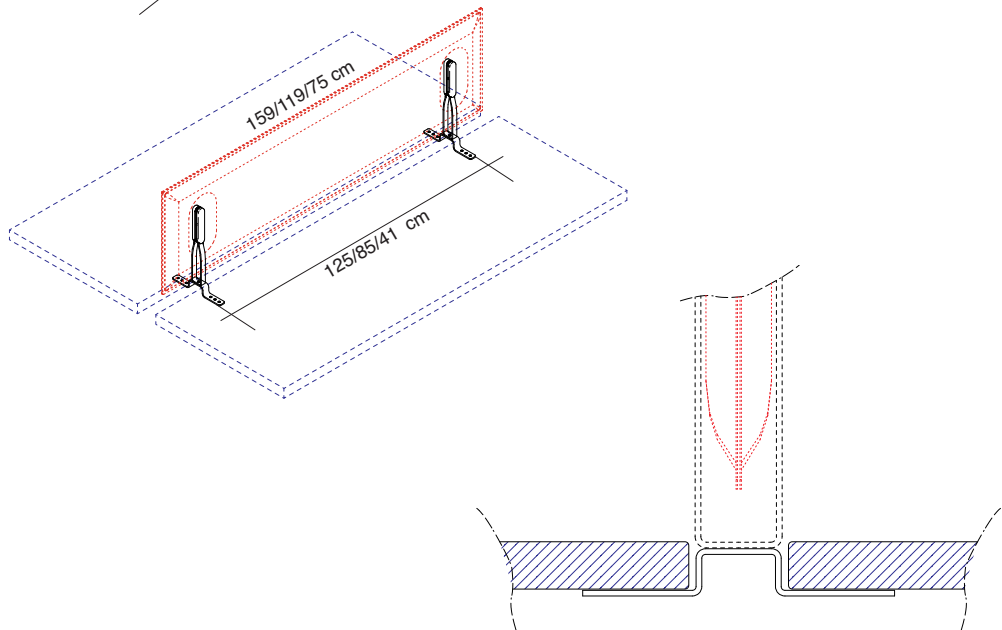
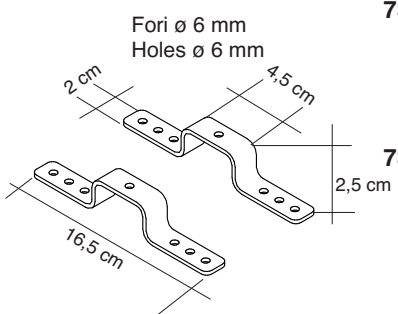

# MITESCO DESK



design Michele De Lucchi  
Snowsound® technology by Caimi Brevetti

Codice Code	Colore Colour	Prezzo Price	Descrizione Description
7M5100-GA	Grigio argento Silver grey Gris argenté Gris plata Silbergrau	1 coppia / 1 pair 1 paire / 1 pare 1 Paar	Coppia staffe con morsetto in acciaio verniciato con polveri epossidiche per fissaggio al piano della scrivania. Attacchi al pannello Mitesco e coperture in tecnopolimero grigio o bianco. <b>Per pannelli Mitesco Desk pag. 56.</b>
7M5100-BO	Bianco opaco Mat white Blanc mat Blanco mate Mattweiß	1 coppia / 1 pair 1 paire / 1 pare 1 Paar	Pair of brackets with clamp in powder-coated steel for connection to the desk top. Mitesco panel connections and front covers in grey or white high-tech polymer. <b>For Mitesco Desk panels page 56.</b>

7M515-GA	Grigio argento Silver grey Gris argenté Gris plata Silbergrau	1 coppia / 1 pair 1 paire / 1 pare 1 Paar	Coppia staffe in acciaio verniciato con polveri epossidiche per fissaggio sotto il piano della scrivania tramite viti (non incluse). Attacchi al pannello Mitesco e coperture in tecnopolimero grigio o bianco. <b>Per pannelli Mitesco Desk pag. 56.</b>
7M515-BO	Bianco opaco Mat white Blanc mat Blanco mate Mattweiß	1 coppia / 1 pair 1 paire / 1 pare 1 Paar	Pair of brackets in powder-coated steel to be fixed under the desk top with screws (not included). Mitesco panel connections and front covers in grey or white high-tech polymer. <b>For Mitesco Desk panels page 56.</b>

# MITESCO DESK

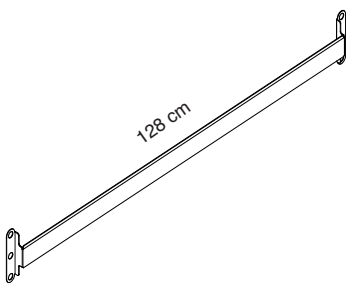
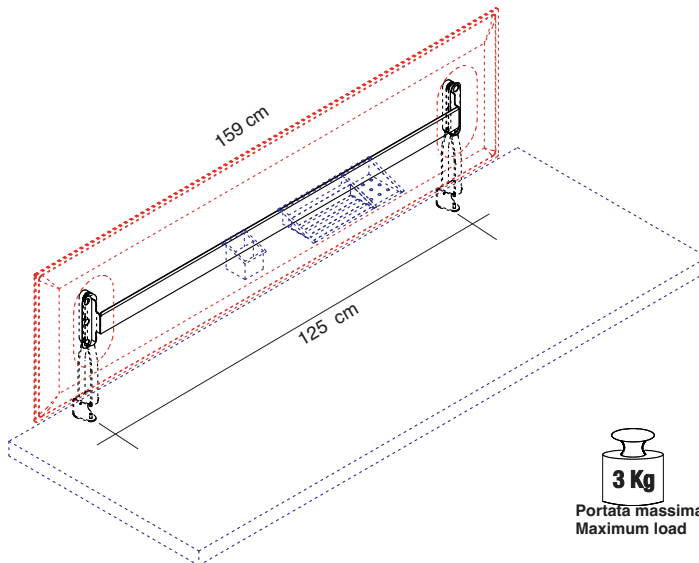
design Michele De Lucchi  
Snowsound® technology by Caimi Brevetti

	Codice Code	Colore Colour	Prezzo Price	Descrizione Description
	<b>7M546-GA</b>	Grigio argento Silver grey Gris argenté Gris plata Silbergrau		Barra porta accessori Desk-up realizzata in acciaio verniciato con polveri epossidiche. Da utilizzare con staffe 7M5100-GA / 7M5100-BO / 7M515-GA / 7M515-BO
	<b>7M546-BO</b>	Bianco opaco Mat white Blanc mat Blanco mate Mattweiß		Epoxy powder-coated steel toolbar for Desk Up accessories. To be used with brackets 7M5100-GA / 7M5100-BO / 7M515-GA / 7M515-BO.
				<p>Profilo pour accessoires Desk-up en acier peint en époxy. Utiliser avec étriers 7M5100-GA / 7M5100-BO / 7M515-GA / 7M515-BO.</p> <p>Perfil para acesorios Desk-Up realizado de acero recubierto epoxi. Utilizacion con abrazaderas 7M5100-GA / 7M5100-BO / 7M515-GA / 7M515-BO.</p> <p>Systemeschiene aus pulverbeschichtetem Stahl für Desk Up-Schalen. Zur Verwendung mit den Halterungen 7M5100-GA / 7M5100-BO / 7M515-GA / 7M515-BO.</p>
				 <p><b>3 Kg</b> Portata massima Maximum load</p>
				 <p><b>1 code 7M515-GA / 7M515-BO o/or 7M5100-GA / 7M5100-BO</b></p> <p><b>2 code 7M546-GA / 7M546-BO</b></p>



# MITESCO DESK

design Michele De Lucchi  
Snowsound® technology by Caimi Brevetti

Codice Code	Colore Colour	Prezzo Price	Descrizione Description
7M517-GA	Grigio argento Silver grey Gris argenté Gris plata Silbergrau	1 coppia / 1 pair 1 paire / 1 pare 1 Paar	Coppia staffe con base in acciaio verniciato con polveri epossidiche per fissaggio al piano della scrivania. Fissaggio al piano obbligatorio a cura del cliente. Scegliere il tipo di fissaggio / incollaggio idoneo alla superficie del piano. Attacchi al pannello Mitesco e coperture in tecnopolimero grigio o bianco. <b>Per pannelli Mitesco Desk pag. 56.</b>
7M517-BO	Bianco opaco Mat white Blanc mat Blanco mate Mattweiß	1 coppia / 1 pair 1 paire / 1 pare 1 Paar	Pair of brackets with base in powder coated steel for fixing to the desk top. Mandatory fastening to the top at customer's care. Choose the most suitable connection/gluing the for the surface. Mitesco panel connections and front covers in grey or white high-tech polymer. <b>For Mitesco Desk panels page 56.</b>
7M519-GA	Grigio argento Silver grey Gris argenté Gris plata Silbergrau	1 coppia / 1 pair 1 paire / 1 pare 1 Paar	Coppia staffe con base in acciaio verniciato con polveri epossidiche per appoggio al piano della scrivania. Attacchi al pannello Mitesco e coperture in tecnopolimero grigio o bianco. <b>Per pannelli Mitesco Desk pag. 56.</b>
7M519-BO	Bianco opaco Mat white Blanc mat Blanco mate Mattweiß	1 coppia / 1 pair 1 paire / 1 pare 1 Paar	Pair of brackets with base in powder coated steel for desk top stand. Mitesco panel connections and front covers in grey or white high-tech polymer. <b>For Mitesco Desk panels page 56.</b>

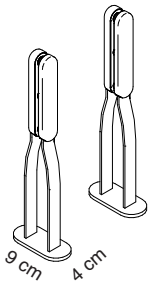

7M517-BO

Bianco opaco  
Mat white  
Blanc mat  
Blanco mate  
Mattweiß

1 coppia / 1 pair  
1 paire / 1 pare  
1 Paar

Pair of brackets with base in powder coated steel for fixing to the desk top. Mandatory fastening to the top at customer's care. Choose the most suitable connection/gluing the for the surface. Mitesco panel connections and front covers in grey or white high-tech polymer. **For Mitesco Desk panels page 56.**

Paire d'étriers avec base en acier peint en époxy à fixer au dessus du bureau. Fixation au dessus obligatoire de la part du client. Choisir le type d'accrochage/collage adapté à la surface du dessus. Accrochages au panneau Mitesco et couvertures en technopolymère gris ou blanc. **Pour Mitesco Desk panneaux page 56.**

Par de embrazaderas con base de acero recubierto epoxi para fijacion al plan del escritorio. Enganche al plano obligatorio por parte del cliente. Elegir el tipo de sujetador / enlace lo mas adecuado para la superficie del plano. Enganches al panel Mitesco y coberturas en polimero gris o blanco. **Para Mitesco Desk panels pag. 56.**

1 Paar Halterungen mit Standfüßen aus pulverbeschichtetem Stahl zur Befestigung auf der Tischplatte. Befestigung durch den Kunden unbedingt erforderlich. Wählen Sie die am besten geeignete Art der Verbindung/Verklebung für die betreffende Oberfläche. Mitesco-Paneelbefestigungen und Abdeckungen aus grauem oder weißem Technopolymer. **Für Mitesco Desk Paneele, Seite 56.**

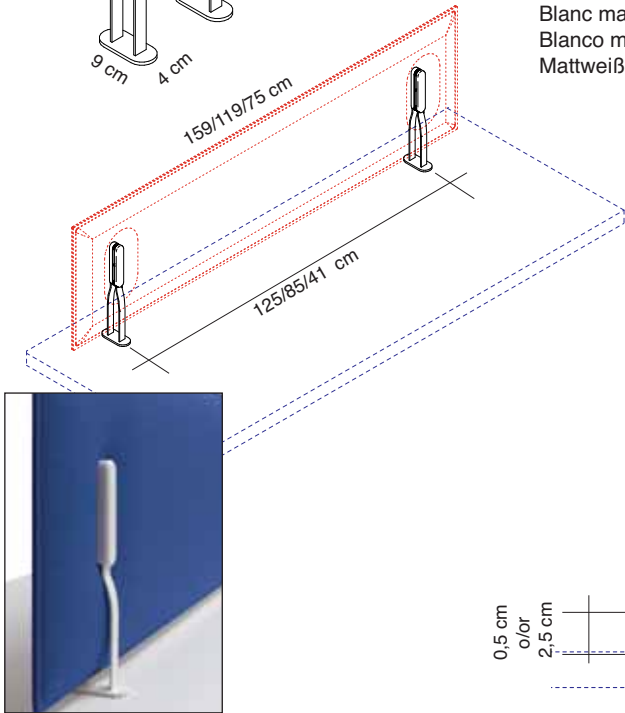

0,5 cm  
o/or  
2,5 cm

44,5 cm o/or 46,5 cm

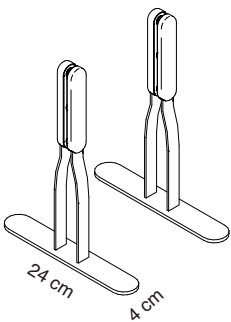

7M519-BO

Bianco opaco  
Mat white  
Blanc mat  
Blanco mate  
Mattweiß

1 coppia / 1 pair  
1 paire / 1 pare  
1 Paar

Pair of brackets with base in powder coated steel for desk top stand. Mitesco panel connections and front covers in grey or white high-tech polymer. **For Mitesco Desk panels page 56.**

Paire d'étriers avec base en acier peint en époxy à poser sur le dessus du bureau. Accrochages au panneau Mitesco et couvertures en technopolymère gris ou blanc. **Pour Mitesco Desk panneaux page 56.**

Par de embrazaderas con base de acero recubierto epoxi para apoyar al escritorio. Enganches al panel Mitesco y coberturas en polimero gris o blanco. **Para Mitesco Desk panels pag. 56.**

Paar Halterungen mit Standfüßen aus pulverbeschichtetem Stahl zur Aufstellung auf der Tischplatte. Mitesco-Paneelbefestigungen und Abdeckungen aus grauem oder weißem Technopolymer. **Für Mitesco Desk Paneele, Seite 56.**

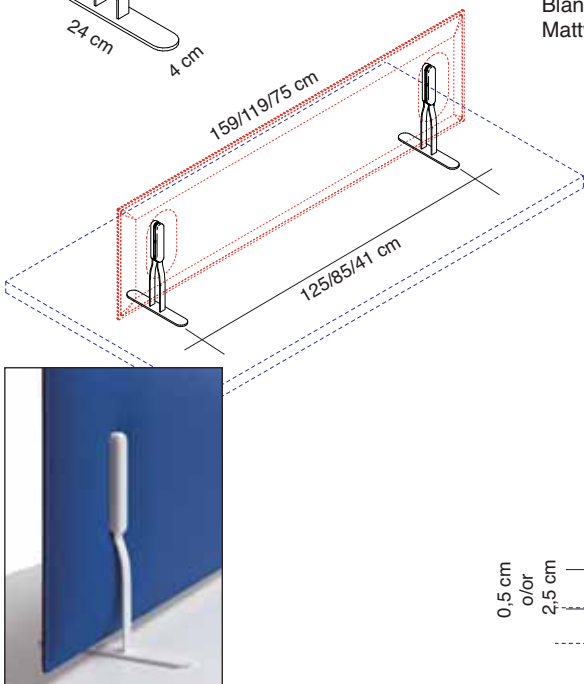

0,5 cm  
o/or  
2,5 cm

44,5 cm o/or 46,5 cm

# MITESCO DESK

design Michele De Lucchi  
Snowsound® technology by Caimi Brevetti

Codice Code	Colore Colour	Prezzo Price	Descrizione Description
7M518-GA	Grigio argento Silver grey Gris argenté Gris plata Silbergrau	1 coppia / 1 pair 1 paire / 1 pare 1 Paar	Coppia staffe con base in acciaio verniciato con polveri epossidiche per appoggio al piano della scrivania. Attacchi al pannello Mitesco e coperture in tecnopolimero grigio o bianco. <b>Per pannelli Mitesco Desk pag. 56.</b>
7M518-BO	Bianco opaco Mat white Blanc mat Blanco mate Mattweiß	1 coppia / 1 pair 1 paire / 1 pare 1 Paar	<p>Pair of brackets with base in powder coated steel for desk top stand. Mitesco panel connections and front covers in grey or white high-tech polymer. <b>For Mitesco Desk panels page 56.</b></p> <p>Paire d'étriers avec base en acier peint en époxy à poser sur le dessus du bureau. Accrochages au panneau Mitesco et couvertures en technopolymère gris ou blanc. <b>Pour Mitesco Desk panneaux page 56.</b></p> <p>Par de abrazaderas con base de acero recubierto epoxi para apoyar al escritorio. Enganches al panel Mitesco y coberturas en polímero gris o blanco. <b>Para Mitesco Desk panels pag. 56.</b></p> <p>Paar Halterungen mit Standfüßen aus pulverbeschichtetem Stahl zur Aufstellung auf der Tischplatte. Mitesco-Paneelbefestigungen und Abdeckungen aus grauem oder weißem Technopolymer. <b>Für Mitesco Desk Paneele, Seite 56.</b></p>

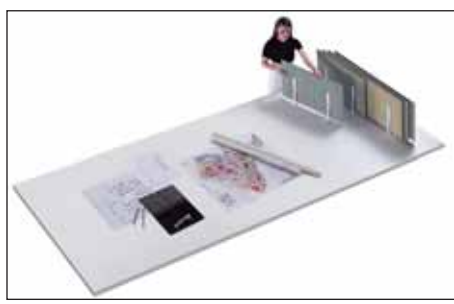
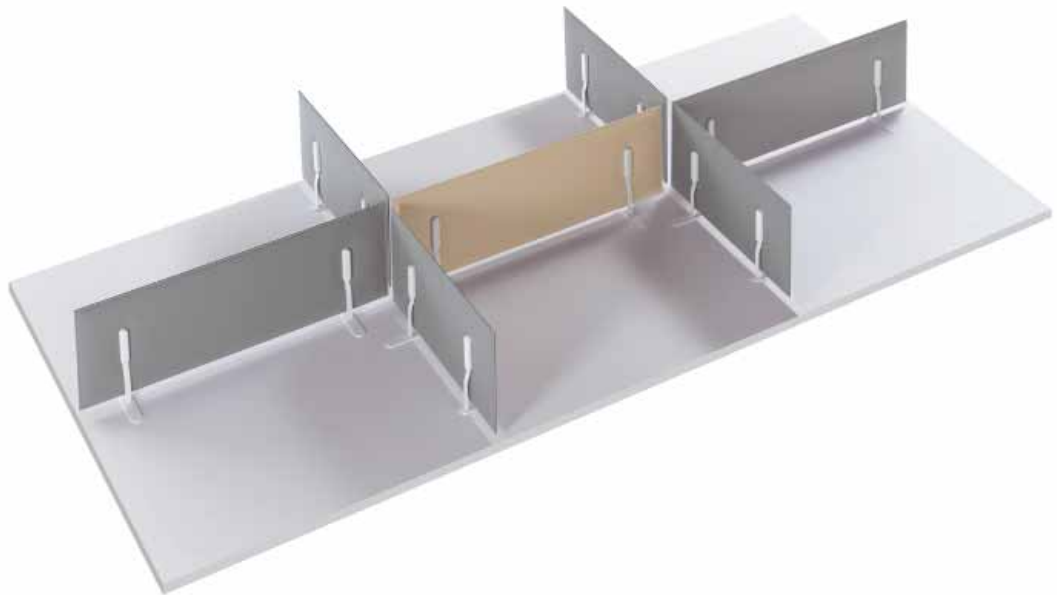
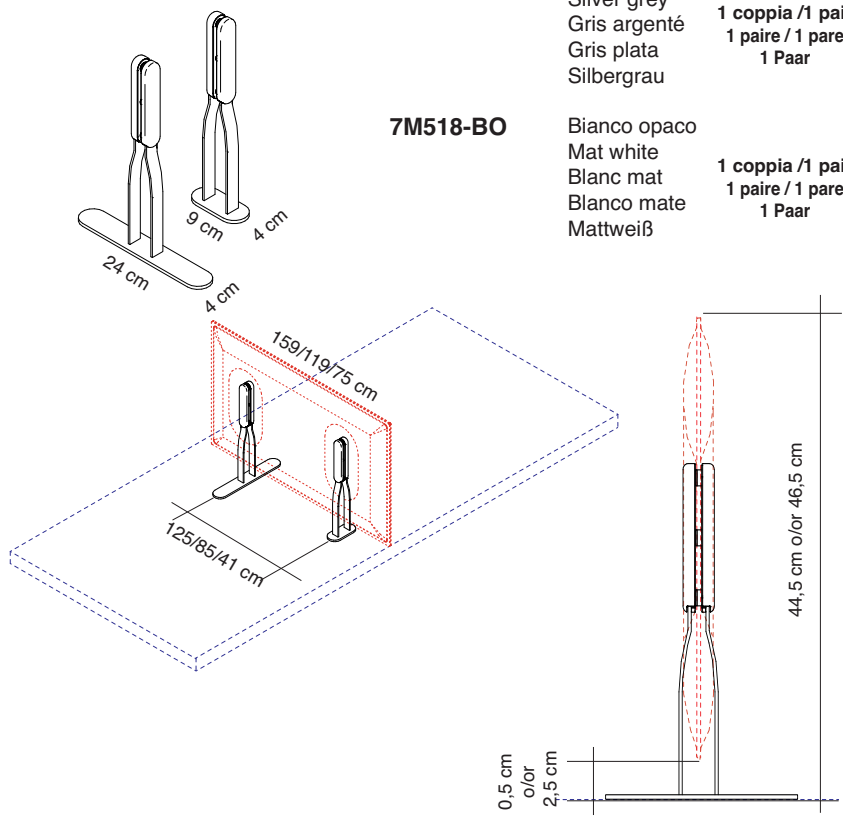

# MITESCO DESK

design Michele De Lucchi  
Snowsound® technology by Caimi Brevetti

Codice Code	Colore Colour	Prezzo Price	Descrizione Description
-------------	---------------	--------------	-------------------------

**7M520-GA**

Grigio argento  
Silver grey  
Gris argenté  
Gris plata  
Silbergrau

Coppia staffe con morsetto in acciaio verniciato con polveri epossidiche per fissaggio al piano della scrivania.  
Attacchi al pannello Mitesco e coperture in tecnopolimero grigio o bianco. **PER DUE PANNELLI Mitesco Desk pag. 56.**

**7M520-BO**

Bianco opaco  
Mat white  
Blanc mat  
Blanco mate  
Mattweiß

Pair of brackets with clamp in powder-coated steel for connection to the desk top.

Mitesco panel connections and front covers in grey or white high-tech polymerl. **FOR TWO Mitesco Desk PANELS page 56.**

Paire d'étriers avec étau en acier peint époxy pour fixation au bureau. Jonctions au panneau Mitesco et couvertures en technopolymère gris ou blanc.

**POUR DEUX Mitesco Desk PANNEAUX page 56.**

Par de abrazaderas con sujetador en acero recubierto epoxi para fijacion al plan del escritorio.

Enganches al panel Mitesco y cobertures de polímero gris o blanco. **PARA DOS Mitesco Desk PANELS pag. 56.**

1 Paar Halterungen aus pulverbeschichtetem Stahl mit Klemmen zur Befestigung an der Tischplatte.

Mitesco-Paneelbefestigungen und Abdeckungen aus grauem oder weissem Technopolymer.

**FUR ZWEI Mitesco Desk PANEELE, Seite 56.**

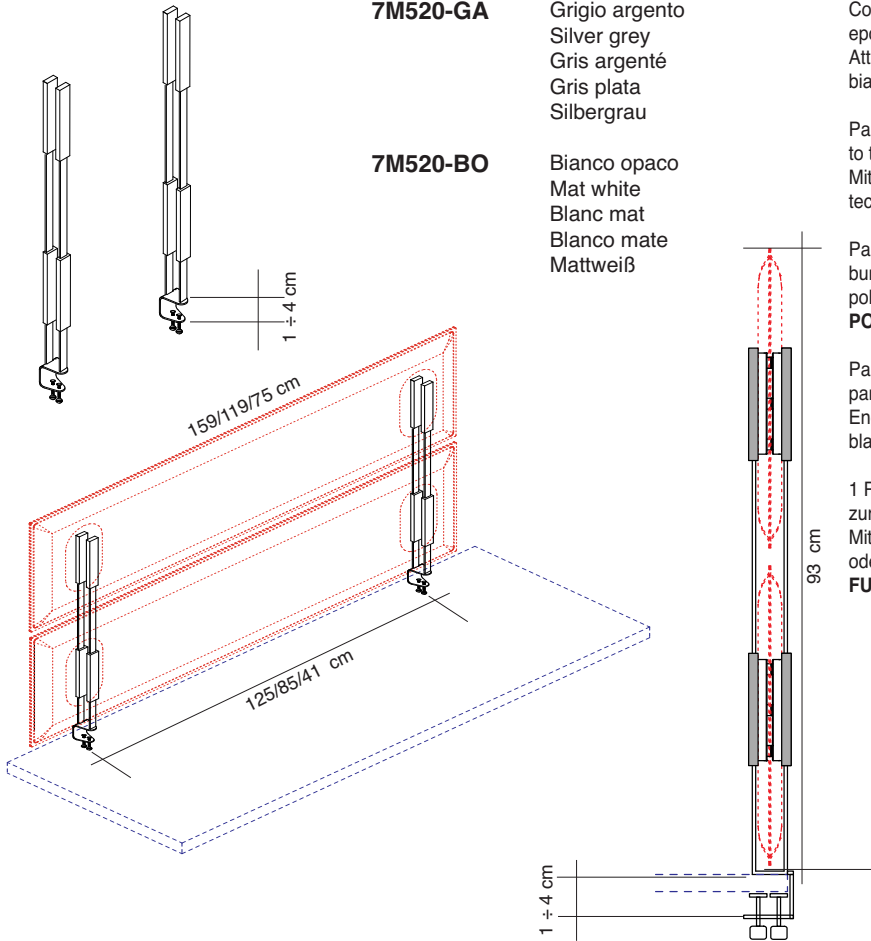



Codice Code	Colore Colour	Prezzo Price	Descrizione Description
7M531-GA	Grigio argento Silver grey Gris argenté Gris plata Silbergrau	1 coppia / 1 pair 1 paire / 1 pare 1 Paar	<p>Coppia attacchi regolabili in acciaio verniciato con polveri epossidiche per pareti già esistenti. Non adatti per pareti in vetro e/o materiali fragili o poco resistenti. <b>Per pannelli Mitesco pag. 9/10/11.</b></p> <p>Pair of adjustable brackets in powder coated steel for existing partitions. Not suitable for glass or fragile partitions. <b>For Mitesco panels page 9/10/11.</b></p> <p>Paire d'accrochages réglables en acier peint en époxy pour cloisons déjà en place. Ils ne sont pas adaptés aux cloisons en verre et/ou matériaux fragiles ou peu résistants. <b>Pour Mitesco panneaux page 9/10/11.</b></p> <p>Par de abrazaderas regulables con base de acero recubierto epoxi para particiones ya existentes. No adecuado para particiones en vidrio o materiales frágiles. Para panel Mitesco. <b>Para Mitesco panels pag. 9/10/11.</b></p> <p>1 Paar verstellbare Befestigungen aus pulverbeschichtetem Stahl zur Aufhängung an Trennwänden. Nicht geeignet für Trennwände aus Glas und/oder zerbrechlichen bzw. nicht widerstandsfähigen Materialien. Zur Verwendung mit Mitesco-Paneelen. <b>Für Mitesco Paneele, Seite 9/10/11.</b></p>

Spessore massimo parete 6 cm  
Max. depth of the partition 6 cm

0 ± 6 cm

0 ± 15 cm

44 cm

7M535-GA	Grigio argento Silver grey Gris argenté Gris plata Silbergrau	1 coppia / 1 pair 1 paire / 1 pare 1 Paar	<p>Coppia agganci regolabili in acciaio verniciato con polveri epossidiche per profili (tipo Desk-Up). <b>Per pannelli Mitesco pag. 9/10/11.</b></p> <p>Pair of adjustable hooks in powder coated steel for profiles (Desk-Up kind). <b>For Mitesco panels pages 9/10/11.</b></p> <p>Paire d'accrochages réglables en acier peint en époxy pour profils (type Desk-Up). <b>Pour Mitesco panneaux page 9/10/11.</b></p> <p>Par de enganches regulables de acero recubierto epoxi para perfiles (tipo Desk-Up). Para panel Mitesco. <b>Para Mitesco panels pag. 9/10/11.</b></p> <p>1 Paar verstellbare Haken aus pulverbeschichtetem Stahl zur Einhängung in Profile (wie z.B. Desk-Up). Zur Verwendung mit Mitesco-Paneelen. <b>Für Mitesco Paneele, Seite 9/10/11.</b></p>
----------	---------------------------------------------------------------------------	-------------------------------------------------	---------------------------------------------------------------------------------------------------------------------------------------------------------------------------------------------------------------------------------------------------------------------------------------------------------------------------------------------------------------------------------------------------------------------------------------------------------------------------------------------------------------------------------------------------------------------------------------------------------------------------------------------------------------------------------------------------------------------------------------------------------------------------------

3.5 cm

13 cm

1 cm

0.4 cm

0.8 cm

0.2 cm

159/119/75 cm

44 cm

10 - 13 - 16 - 19 cm

1



**Descrizione**  
**Description**

Pannello con imbottitura interna in poliester a **densità variabile** Snowsound® Technology. Rivestimento esterno in tessuto di poliester Trevira CS®.

Panel with polyester internal padding with Snowsound® Technology **variable density**. Polyester covering in Trevira CS® fabric. .

Panneau avec rembourrage interne en polyester à **densité variable** Snowsound® Technology. Revêtement externe en tissu de polyester Trevira CS®.

Panel con acolchado interior de poliéster de **densidad variable** Snowsound® Technology. Revestimiento exterior de tejido de poliéster Trevira CS®.

Panel mit Polyester-Füllmaterial von **unterschiedlicher Dichte** Snowsound® Technology. Polyester-Bezug aus Trevira CS®-Material.

- 1) Posizionare le staffe cod. 7S111-GA / 7S111-BO / 7S1100-GA / 7S1100-BO
- 1) Position the brackets code 7S111-GA / 7S111-BO / 7S1100-GA / 7S1100-BO
- 1) Posionnez les étriers cod. 7S111-GA / 7S111-BO / 7S1100-GA / 7S1100-BO
- 1) Colocar los soportes cod. 7S111-GA / 7S111-BO / 7S1100-GA / 7S1100-BO
- 1) Positionieren Sie die Halterungen Art. Nr 7S111-GA / 7S111-BO / 7S1100-GA / 7S1100-BO

2 / 3

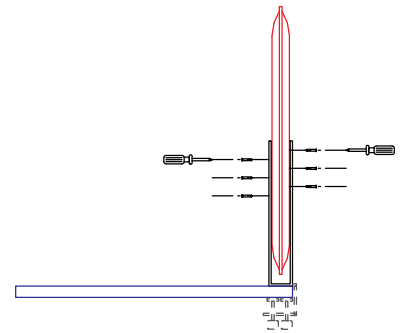

- 2 e 3) Avvitare le staffe cod 7S111-GA / 7S111-BO / 7S1100-GA / 7S1100-BO direttamente al pannello e applicare la copertura in tecnopolimero.
- 2 e 3) Directly screw the brackets code 7S111-GA / 7S111-BO / 7S1100-GA / 7S1100-BO to the panels and put on the hi-tech polymer front cover.
- 2 e 3) Vissez les supports cod 7S111-GA / 7S111-BO / 7S1100-GA / 7S1100-BO directement au panneau et appliquez les couvertures en technopolymere.
- 2 e 3) Atornillar los soportes cod 7S111-GA / 7S111-BO / 7S1100-GA / 7S1100-BO directamente al panel y aplicar las coberturas en tecnopolimero.
- 2 e 3) Schrauben Sie die Halterungen Art. Nr. 7S111-GA / 7S111-BO / 7S1100-GA / 7S1100-BO direkt an das Paneel und befestigen Sie die vordere Abdeckung aus Hi-Tech-Polymer.

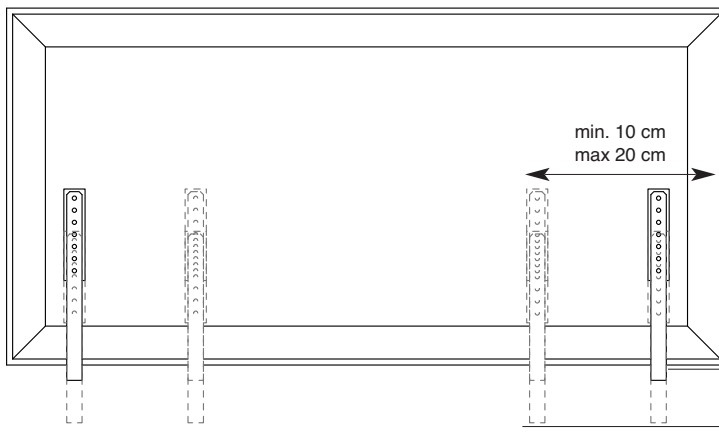

Le staffe possono essere applicate lungo il pannello.  
The brackets can be positioned along the panel.  
Les supports peuvent être appliqués le long du panneau.  
Los soportes pueden ser posicionados a lo largo del panel.  
Die Halterungen können beliebig entlang des Paneels angebracht werden.

# SNOWDESK

Snowsound® technology by Caimi Brevetti

PER APPLICAZIONI A SCRIVANIA - DESK MOUNTING - MONTAGE SUR LE BUREAU -  
MONTAJE SOBRE MESAS DE ESCRITORIO - TISCHBEFESTIGUNG

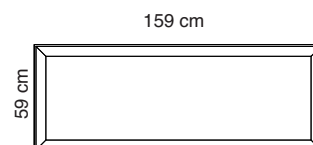
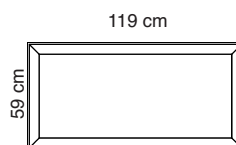
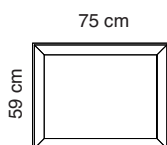
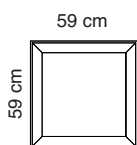

	Codice/Code Prezzo/Price	Codice/Code Prezzo/Price	Codice/Code Prezzo/Price	Codice/Code Prezzo/Price
Bianco White Blanc <b>0001</b>	<b>7S066-0001</b>	<b>7S086-0001</b>	<b>7S126-0001</b>	<b>7S166-0001</b>
Grigio argento Silver grey Gris argenté <b>8004</b>	<b>7S066-8004</b>	<b>7S086-8004</b>	<b>7S126-8004</b>	<b>7S166-8004</b>
Grigio scuro Dark grey Gris foncé <b>8007</b>	<b>7S066-8007</b>	<b>7S086-8007</b>	<b>7S126-8007</b>	<b>7S166-8007</b>
Beige Beige Beige <b>1008</b>	<b>7S066-1008</b>	<b>7S086-1008</b>	<b>7S126-1008</b>	<b>7S166-1008</b>
Tortora Dove-grey Taupe <b>2005</b>	<b>7S066-2005</b>	<b>7S086-2005</b>	<b>7S126-2005</b>	<b>7S166-2005</b>
Giallo Yellow Jaune <b>3008</b>	<b>7S066-3008</b>	<b>7S086-3008</b>	<b>7S126-3008</b>	<b>7S166-3008</b>
Arancione Orange Orange <b>4030</b>	<b>7S066-4030</b>	<b>7S086-4030</b>	<b>7S126-4030</b>	<b>7S166-4030</b>
Rosso Red Rouge <b>4027</b>	<b>7S066-4027</b>	<b>7S086-4027</b>	<b>7S126-4027</b>	<b>7S166-4027</b>
Verde chiaro Light green Vert clair <b>7004</b>	<b>7S066-7004</b>	<b>7S086-7004</b>	<b>7S126-7004</b>	<b>7S166-7004</b>
Verde Green Vert <b>7013</b>	<b>7S066-7013</b>	<b>7S086-7013</b>	<b>7S126-7013</b>	<b>7S166-7013</b>
Blu Blue Bleu <b>6071</b>	<b>7S066-6071</b>	<b>7S086-6071</b>	<b>7S126-6071</b>	<b>7S166-6071</b>
Nero Black Noir <b>8033</b>	<b>7S066-8033</b>	<b>7S086-8033</b>	<b>7S126-8033</b>	<b>7S166-8033</b>

	Codice Code	Colore Colour	Prezzo Price	Descrizione Description
	<b>7S511-GA</b>	Grigio argento Silver grey Gris argenté Gris plata Silbergrau	<b>1 coppia / 1 pair</b> <b>1 paire / 1 pare</b> <b>1 Paar</b>	Coppia staffe in acciaio verniciato con polveri epossidiche per fissaggio sopra il piano della scrivania tramite viti (non incluse). Attacchi al pannello Snowdesk e coperture in tecnopolimero grigio o bianco. <b>Per pannelli Snowdesk pag. 65.</b>
	<b>7S511-BO</b>	Bianco opaco Mat white Blanc mat Blanco mate Mattweiß	<b>1 coppia / 1 pair</b> <b>1 paire / 1 pare</b> <b>1 Paar</b>	Pair of brackets in powder-coated steel to be fixed on the desk top with screws (not included). Snowdesk Panel connections and front covers in grey or white high-tech polymer. <b>For Snowdesk panels page 65.</b>
				<p>Paire d'étriers en acier peint époxy pour fixation sur le bureau par des vis (pas incluses). Jonctions au panneau Snowdesk et couvertures en technopolymère gris ou blanc. <b>Pour Snowdesk panneaux page 65.</b></p> <p>Par de abrazaderas de acero recubierto epoxi para fijación sobre el plan del escritorio por medio de tornillos (no incluydos). Enganches al panel Snowdesk y coberturas de polímero gris o blanco. <b>Para Snowdesk panels pag. 65.</b></p> <p>1 Paar Halterungen aus pulverbeschichtetem Stahl zur Befestigung auf der Tischplatte durch Schrauben (nicht inkludiert). Snowdesk-Paneelbefestigungen und Abdeckungen aus grauem oder weissem Technopolymer. <b>Für Snowdesk Paneele, Seite 65.</b></p>

	<b>7S100-GA</b>	Grigio argento Silver grey Gris argenté Gris plata Silbergrau	<b>1 coppia / 1 pair</b> <b>1 paire / 1 pare</b> <b>1 Paar</b>	Da utilizzare con staffe 7S511-GA / 7S511-BO.
	<b>7S100-BO</b>	Bianco opaco Mat white Blanc mat Blanco mate Mattweiß	<b>1 coppia / 1 pair</b> <b>1 paire / 1 pare</b> <b>1 Paar</b>	To be used with brackets 7S511-GA / 7S511-BO.
				<p>Utiliser avec étriers 7S511-GA / 7S511-BO.</p> <p>Utilización con abrazaderas 7S511-GA / 7S511-BO.</p> <p>Zur Verwendung mit den Halterungen 7S511-GA / 7S511-BO.</p>

# SNOWDESK

Snowsound® technology by Caimi Brevetti

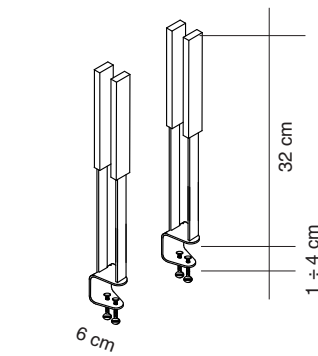

**7S1100-GA**

Grigio argento  
Silver grey  
Gris argenté  
Gris plata  
Silbergrau

1 coppia / 1 pair  
1 paire / 1 pare  
1 Paar

Coppia staffe con morsetto in acciaio verniciato con polveri epossidiche per fissaggio al piano della scrivania. Attacchi al pannello Snowdesk e coperture in tecnopolimero grigio o bianco. **Per pannelli Snowdesk pag. 65.**

**7S1100-BO**

Bianco opaco  
Mat white  
Blanc mat  
Blanco mate  
Mattweiß

1 coppia / 1 pair  
1 paire / 1 pare  
1 Paar

Pair of brackets with clamp in powder-coated steel for connection to the desk top. Snowdesk panel connections and front covers in grey or white high-tech polymer. **For Snowdesk panels page 65.**

Paire d'étriers avec étau en acier peint époxy pour fixation au bureau. Jonctions au panneau Snowdesk et couvertures en technopolymère gris ou blanc. **Pour Snowdesk panneaux page 65.**

Par de abrazaderas con sujetador en acero recubierto epoxi para fijación al plan del escritorio. Enganches al panel Snowdesk y coberturas de polímero gris o blanco. **Para Snowdesk panels pag. 65.**

1 Paar Halterungen aus pulverbeschichtetem Stahl mit Klammern zur Befestigung an der Tischplatte. Snowdesk-Paneelbefestigungen und Abdeckungen aus grauem oder weissem Technopolymer. **Für Snowdesk Paneele, Seite 65.**

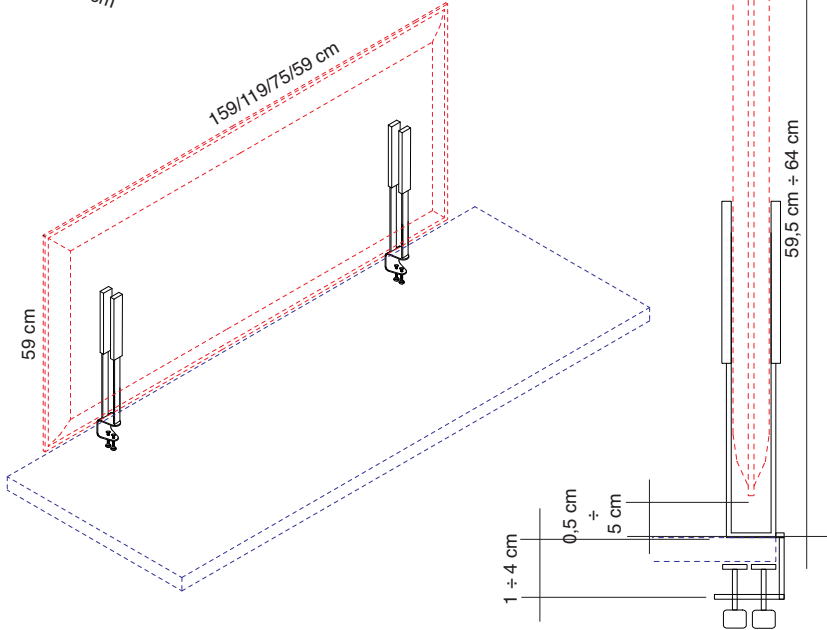

# FLAP / MAXIFLAP

design Alberto Meda, Francesco Meda  
Snowsound® technology by Caimi Brevetti

## FLAP

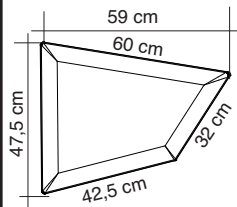
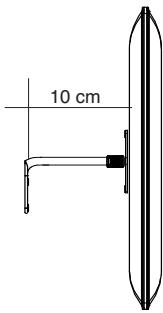

Colore  
Colour

Codice / Code  
Prezzo / Price

Bianco White Blanc 0001	7F1007-0001 cad/each
----------------------------------	-------------------------

2 pz. per scatola / Box of 2 pcs / Condit. à 2 pcs  
2 pz. por embalaje / Verpackungseinheit 2 St.

Grigio argento Silver grey Gris argenté 8004	7F1007-8004 cad/each
-------------------------------------------------------	-------------------------

2 pz. per scatola / Box of 2 pcs / Condit. à 2 pcs  
2 pz. por embalaje / Verpackungseinheit 2 St.

Grigio scuro Dark grey Gris foncté 8007	7F1007-8007 cad/each
--------------------------------------------------	-------------------------

2 pz. per scatola / Box of 2 pcs / Condit. à 2 pcs  
2 pz. por embalaje / Verpackungseinheit 2 St.

Beige Beige Beige 1008	7F1007-1008 cad/each
---------------------------------	-------------------------

2 pz. per scatola / Box of 2 pcs / Condit. à 2 pcs  
2 pz. por embalaje / Verpackungseinheit 2 St.

Tortora Dove-grey Taupe 2005	7F1007-2005 cad/each
---------------------------------------	-------------------------

2 pz. per scatola / Box of 2 pcs / Condit. à 2 pcs  
2 pz. por embalaje / Verpackungseinheit 2 St.

Giallo Yellow Jaune 3008	7F1007-3008 cad/each
-----------------------------------	-------------------------

2 pz. per scatola / Box of 2 pcs / Condit. à 2 pcs  
2 pz. por embalaje / Verpackungseinheit 2 St.

Arancione Orange Orange 4030	7F1007-4030 cad/each
---------------------------------------	-------------------------

2 pz. per scatola / Box of 2 pcs / Condit. à 2 pcs  
2 pz. por embalaje / Verpackungseinheit 2 St.

Rosso Red Rouge 4027	7F1007-4027 cad/each
-------------------------------	-------------------------

2 pz. per scatola / Box of 2 pcs / Condit. à 2 pcs  
2 pz. por embalaje / Verpackungseinheit 2 St.

Verde chiaro Light green Vert clair 7004	7F1007-7004 cad/each
---------------------------------------------------	-------------------------

2 pz. per scatola / Box of 2 pcs / Condit. à 2 pcs  
2 pz. por embalaje / Verpackungseinheit 2 St.

Verde Green Vert 7013	7F1007-7013 cad/each
--------------------------------	-------------------------

2 pz. per scatola / Box of 2 pcs / Condit. à 2 pcs  
2 pz. por embalaje / Verpackungseinheit 2 St.

Blu Blue Bleu 6071	7F1007-6071 cad/each
-----------------------------	-------------------------

2 pz. per scatola / Box of 2 pcs / Condit. à 2 pcs  
2 pz. por embalaje / Verpackungseinheit 2 St.

Nero Black Noir 8033	7F1007-8033 cad/each
-------------------------------	-------------------------

2 pz. per scatola / Box of 2 pcs / Condit. à 2 pcs  
2 pz. por embalaje / Verpackungseinheit 2 St.

## MAXIFLAP

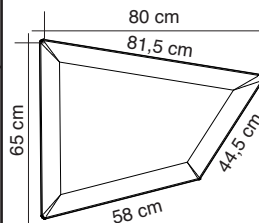
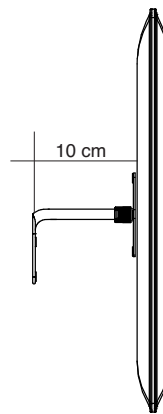

Colore  
Colour

Codice / Code  
Prezzo / Price

Bianco White Blanc 0001	7F2007-0001 cad/each
----------------------------------	-------------------------

2 pz. per scatola / Box of 2 pcs / Condit. à 2 pcs  
2 pz. por embalaje / Verpackungseinheit 2 St.

Grigio argento Silver grey Gris argenté 8004	7F2007-8004 cad/each
-------------------------------------------------------	-------------------------

2 pz. per scatola / Box of 2 pcs / Condit. à 2 pcs  
2 pz. por embalaje / Verpackungseinheit 2 St.

Grigio scuro Dark grey Gris foncté 8007	7F2007-8007 cad/each
--------------------------------------------------	-------------------------

2 pz. per scatola / Box of 2 pcs / Condit. à 2 pcs  
2 pz. por embalaje / Verpackungseinheit 2 St.

Beige Beige Beige 1008	7F2007-1008 cad/each
---------------------------------	-------------------------

2 pz. per scatola / Box of 2 pcs / Condit. à 2 pcs  
2 pz. por embalaje / Verpackungseinheit 2 St.

Tortora Dove-grey Taupe 2005	7F2007-2005 cad/each
---------------------------------------	-------------------------

2 pz. per scatola / Box of 2 pcs / Condit. à 2 pcs  
2 pz. por embalaje / Verpackungseinheit 2 St.

Giallo Yellow Jaune 3008	7F2007-3008 cad/each
-----------------------------------	-------------------------

2 pz. per scatola / Box of 2 pcs / Condit. à 2 pcs  
2 pz. por embalaje / Verpackungseinheit 2 St.

Arancione Orange Orange 4030	7F2007-4030 cad/each
---------------------------------------	-------------------------

2 pz. per scatola / Box of 2 pcs / Condit. à 2 pcs  
2 pz. por embalaje / Verpackungseinheit 2 St.

Rosso Red Rouge 4027	7F2007-4027 cad/each
-------------------------------	-------------------------

2 pz. per scatola / Box of 2 pcs / Condit. à 2 pcs  
2 pz. por embalaje / Verpackungseinheit 2 St.

Verde chiaro Light green Vert clair 7004	7F2007-7004 cad/each
---------------------------------------------------	-------------------------

2 pz. per scatola / Box of 2 pcs / Condit. à 2 pcs  
2 pz. por embalaje / Verpackungseinheit 2 St.

Verde Green Vert 7013	7F2007-7013 cad/each
--------------------------------	-------------------------

2 pz. per scatola / Box of 2 pcs / Condit. à 2 pcs  
2 pz. por embalaje / Verpackungseinheit 2 St.

Blu Blue Bleu 6071	7F2007-6071 cad/each
-----------------------------	-------------------------

2 pz. per scatola / Box of 2 pcs / Condit. à 2 pcs  
2 pz. por embalaje / Verpackungseinheit 2 St.

Nero Black Noir 8033	7F2007-8033 cad/each
-------------------------------	-------------------------

2 pz. per scatola / Box of 2 pcs / Condit. à 2 pcs  
2 pz. por embalaje / Verpackungseinheit 2 St.



# FLAP / MAXIFLAP

design Alberto Meda, Francesco Meda  
Snowsound® technology by Caimi Brevetti

## FLAP

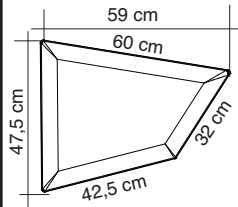
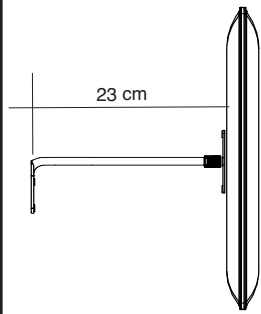

Colore  
Colour

Codice / Code  
Prezzo / Price

Bianco White Blanc <b>0001</b>	<b>7F1020-0001</b> cad/each
-----------------------------------------	--------------------------------

2 pz. per scatola / Box of 2 pcs / Condit. à 2 pcs  
2 pz. por embalaje / Verpackungseinheit 2 St.

Grigio argento Silver grey Gris argenté <b>8004</b>	<b>7F1020-8004</b> cad/each
--------------------------------------------------------------	--------------------------------

2 pz. per scatola / Box of 2 pcs / Condit. à 2 pcs  
2 pz. por embalaje / Verpackungseinheit 2 St.

Grigio scuro Dark grey Gris foncté <b>8007</b>	<b>7F1020-8007</b> cad/each
---------------------------------------------------------	--------------------------------

2 pz. per scatola / Box of 2 pcs / Condit. à 2 pcs  
2 pz. por embalaje / Verpackungseinheit 2 St.

Beige Beige Beige <b>1008</b>	<b>7F1020-1008</b> cad/each
----------------------------------------	--------------------------------

2 pz. per scatola / Box of 2 pcs / Condit. à 2 pcs  
2 pz. por embalaje / Verpackungseinheit 2 St.

Tortora Dove-grey Taupe <b>2005</b>	<b>7F1020-2005</b> cad/each
----------------------------------------------	--------------------------------

2 pz. per scatola / Box of 2 pcs / Condit. à 2 pcs  
2 pz. por embalaje / Verpackungseinheit 2 St.

Giallo Yellow Jaune <b>3008</b>	<b>7F1020-3008</b> cad/each
------------------------------------------	--------------------------------

2 pz. per scatola / Box of 2 pcs / Condit. à 2 pcs  
2 pz. por embalaje / Verpackungseinheit 2 St.

Arancione Orange Orange <b>4030</b>	<b>7F1020-4030</b> cad/each
----------------------------------------------	--------------------------------

2 pz. per scatola / Box of 2 pcs / Condit. à 2 pcs  
2 pz. por embalaje / Verpackungseinheit 2 St.

Rosso Red Rouge <b>4027</b>	<b>7F1020-4027</b> cad/each
--------------------------------------	--------------------------------

2 pz. per scatola / Box of 2 pcs / Condit. à 2 pcs  
2 pz. por embalaje / Verpackungseinheit 2 St.

Verde chiaro Light green Vert clair <b>7004</b>	<b>7F1020-7004</b> cad/each
----------------------------------------------------------	--------------------------------

2 pz. per scatola / Box of 2 pcs / Condit. à 2 pcs  
2 pz. por embalaje / Verpackungseinheit 2 St.

Verde Green Vert <b>7013</b>	<b>7F1020-7013</b> cad/each
---------------------------------------	--------------------------------

2 pz. per scatola / Box of 2 pcs / Condit. à 2 pcs  
2 pz. por embalaje / Verpackungseinheit 2 St.

Blu Blue Bleu <b>6071</b>	<b>7F1020-6071</b> cad/each
------------------------------------	--------------------------------

2 pz. per scatola / Box of 2 pcs / Condit. à 2 pcs  
2 pz. por embalaje / Verpackungseinheit 2 St.

Nero Black Noir <b>8033</b>	<b>7F1020-8033</b> cad/each
--------------------------------------	--------------------------------

2 pz. per scatola / Box of 2 pcs / Condit. à 2 pcs  
2 pz. por embalaje / Verpackungseinheit 2 St.

## MAXIFLAP

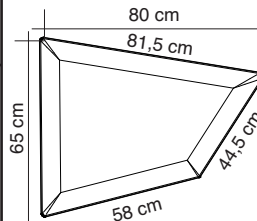
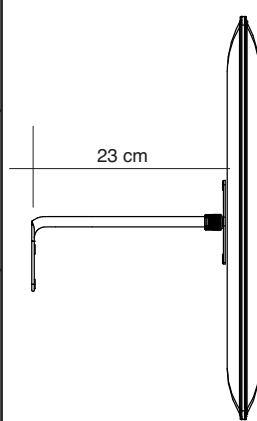

Colore  
Colour

Codice / Code  
Prezzo / Price

Bianco White Blanc <b>0001</b>	<b>7F2020-0001</b> cad/each
-----------------------------------------	--------------------------------

2 pz. per scatola / Box of 2 pcs / Condit. à 2 pcs  
2 pz. por embalaje / Verpackungseinheit 2 St.

Grigio argento Silver grey Gris argenté <b>8004</b>	<b>7F2020-8004</b> cad/each
--------------------------------------------------------------	--------------------------------

2 pz. per scatola / Box of 2 pcs / Condit. à 2 pcs  
2 pz. por embalaje / Verpackungseinheit 2 St.

Grigio scuro Dark grey Gris foncté <b>8007</b>	<b>7F2020-8007</b> cad/each
---------------------------------------------------------	--------------------------------

2 pz. per scatola / Box of 2 pcs / Condit. à 2 pcs  
2 pz. por embalaje / Verpackungseinheit 2 St.

Beige Beige Beige <b>1008</b>	<b>7F2020-1008</b> cad/each
----------------------------------------	--------------------------------

2 pz. per scatola / Box of 2 pcs / Condit. à 2 pcs  
2 pz. por embalaje / Verpackungseinheit 2 St.

Tortora Dove-grey Taupe <b>2005</b>	<b>7F2020-2005</b> cad/each
----------------------------------------------	--------------------------------

2 pz. per scatola / Box of 2 pcs / Condit. à 2 pcs  
2 pz. por embalaje / Verpackungseinheit 2 St.

Giallo Yellow Jaune <b>3008</b>	<b>7F2020-3008</b> cad/each
------------------------------------------	--------------------------------

2 pz. per scatola / Box of 2 pcs / Condit. à 2 pcs  
2 pz. por embalaje / Verpackungseinheit 2 St.

Arancione Orange Orange <b>4030</b>	<b>7F2020-4030</b> cad/each
----------------------------------------------	--------------------------------

2 pz. per scatola / Box of 2 pcs / Condit. à 2 pcs  
2 pz. por embalaje / Verpackungseinheit 2 St.

Rosso Red Rouge <b>4027</b>	<b>7F2020-4027</b> cad/each
--------------------------------------	--------------------------------

2 pz. per scatola / Box of 2 pcs / Condit. à 2 pcs  
2 pz. por embalaje / Verpackungseinheit 2 St.

Verde chiaro Light green Vert clair <b>7004</b>	<b>7F2020-7004</b> cad/each
----------------------------------------------------------	--------------------------------

2 pz. per scatola / Box of 2 pcs / Condit. à 2 pcs  
2 pz. por embalaje / Verpackungseinheit 2 St.

Verde Green Vert <b>7013</b>	<b>7F2020-7013</b> cad/each
---------------------------------------	--------------------------------

2 pz. per scatola / Box of 2 pcs / Condit. à 2 pcs  
2 pz. por embalaje / Verpackungseinheit 2 St.

Blu Blue Bleu <b>6071</b>	<b>7F2020-6071</b> cad/each
------------------------------------	--------------------------------

2 pz. per scatola / Box of 2 pcs / Condit. à 2 pcs  
2 pz. por embalaje / Verpackungseinheit 2 St.

Nero Black Noir <b>8033</b>	<b>7F2020-8033</b> cad/each
--------------------------------------	--------------------------------

2 pz. per scatola / Box of 2 pcs / Condit. à 2 pcs  
2 pz. por embalaje / Verpackungseinheit 2 St.

# FLAP / MAXIFLAP

design Alberto Meda, Francesco Meda  
Snowsound® technology by Caimi Brevetti

Alcuni esempi di possibili composizioni con pannelli Flap/Maxiflap cod. 7F1007-XXXX / 7F1020-XXXX / 7F2007-XXXX e 7F2020-XXXX (XXXX = Variante colore) e relativi ingombri indicativi.

Some examples of possible compositions with panels Flap/Maxiflap cod. 7F1007-XXXX / 7F1020-XXXX / 7F2007-XXXX and 7F2020-XXXX (XXXX = Colour option) and related indicative dimensions.

Quelques exemples de compositions possibles avec les panneaux Flap/Maxiflap code 7F1007-XXXX / 7F1020-XXXX / 7F2007-XXXX et 7F2020-XXXX (XXXX = option couleur) et dimensions indicatives.

Algunos ejemplos de posibles composiciones con paneles Flap/Maxiflap cod. 7F1007-XXXX / 7F1020-XXXX / 7F2007-XXXX y 7F2020-XXXX (XXXX = Variante color) y dimensiones indicativas correspondientes.

Einige Beispiele von möglichen Zusammenstellungen der Flap/Maxiflap-Paneele Art.Nr. 7F1007-XXXX / 7F1020-XXXX / 7F2007-XXXX und 7F2020-XXXX (XXXX = Farbvariante) mit den jeweiligen ungefähren Abmessungen.

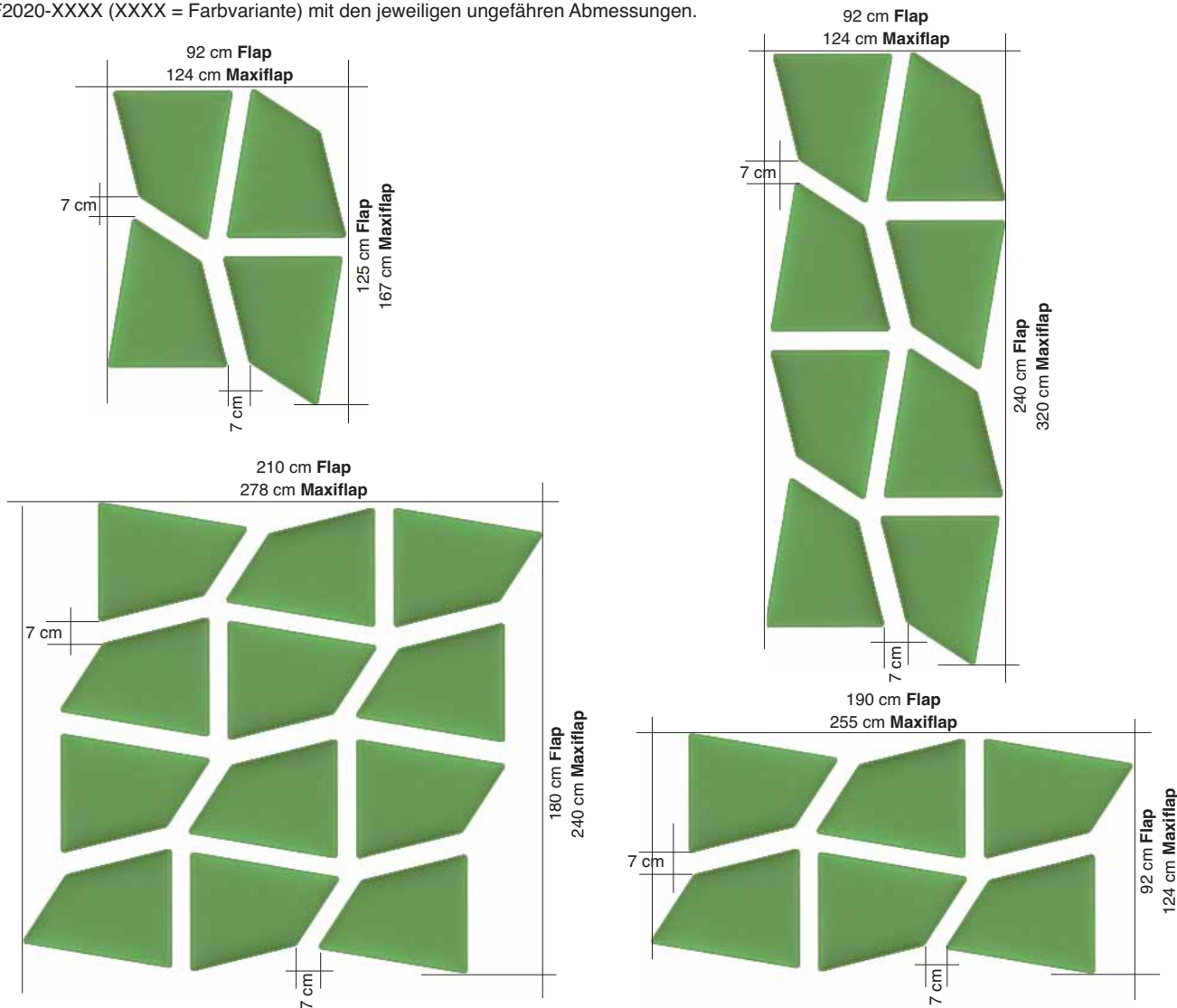

## Descrizione

### Description

Pannello con imbottitura interna in poliester a **densità variabile** Snowsound® Technology. Rivestimento esterno in tessuto di poliester Trevira CS®.

Completo di braccio in acciaio cromato per fissaggio a parete o a soffitto (viti non incluse).

Il pannello è inclinabile in tutte le direzioni e può ruotare di 360°.

Panel with polyester internal padding with Snowsound® Technology **variable density**. Polyester covering in Trevira CS® fabric. Equipped with chrome-plated steel bracket for wall or ceiling fixing (screws not included). The panel can be tilted in any direction and can rotate 360 degrees.

Panneau avec rembourrage interne en polyester à **densité variable** Snowsound® Technology. Revêtement externe en tissu de polyester Trevira CS®. Fourni avec bras en acier chromé pour fixation au mur ou au plafond (vis pas inclus) Le panneau peut être incliné dans toutes les directions et pivoter sur 360°.

Panel con acolchado interior de poliéster de **densidad variable** Snowsound® Technology. Revestimiento exterior en tejido de poliéster Trevira CS®. Completo con brazo de acero cromado para fijación a pared o al techo (tornillos no incluidos). El panel es inclinable en todas direcciones y puede rotar a 360°.

Panel with Polyester-Füllmaterial von **unterschiedlicher Dichte** Snowsound® Technology. Polyester-Bezug aus Trevira CS®-Material. Ausgestattet mit einem Montagewinkel mit Kugelgelenk zur Befestigung an Wand oder Decke (Schrauben nicht inkludiert). Das Paneel kann in jede Richtung geneigt und um 360 Grad gedreht werden.

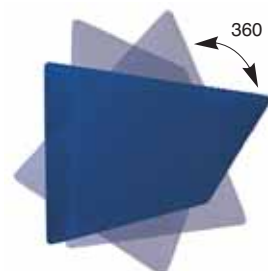
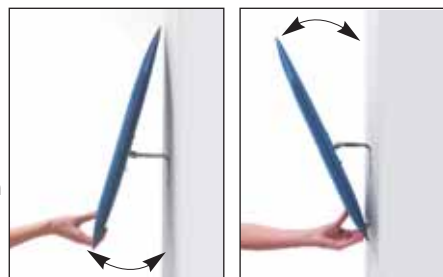

# FLAP / MAXIFLAP

design Alberto Meda, Francesco Meda  
Snowsound® technology by Caimi Brevetti

Esempio utilizzo dime fornite con i pannelli Flap/Maxiflap cod. 7F1007-XXXX / 7F1020-XXXX / 7F2007-XXXX e 7F2020-XXXX (XXXX = Variante colore).

Example for the use of templates provided with Flap/Maxiflap panels cod. 7F1007-XXXX / 7F1020-XXXX / 7F2007-XXXX and 7F2020-XXXX (XXXX = Colour option).

Exemples d'utilisation modèles fournis avec les panneaux Flap/Maxiflap code 7F1007-XXXX / 7F1020-XXXX / 7F2007-XXXX et 7F2020-XXXX (XXXX = option couleur).

Ejemplo de uso de las plantillas suministradas con los paneles Flap/Maxiflap cod. 7F1007-XXXX / 7F1020-XXXX / 7F2007-XXXX y 7F2020-XXXX (XXXX = Variante color).

Beispiel für die Verwendung der mit den Flap/Maxiflap Paneelen Art.Nr. 7F1007-XXXX / 7F1020-XXXX / 7F2007-XXXX und 7F2020-XXXX (XXXX = Farbvariante) mitgelieferten Papierschablone.

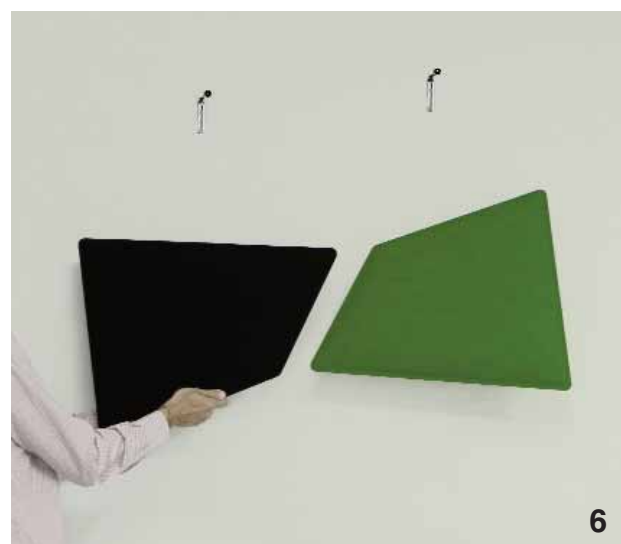
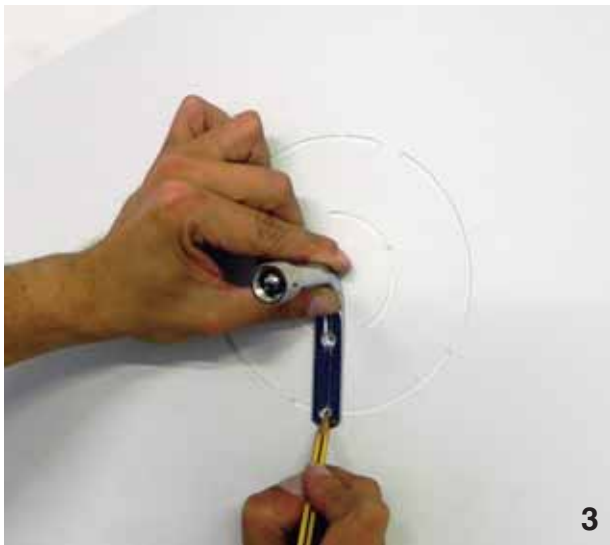
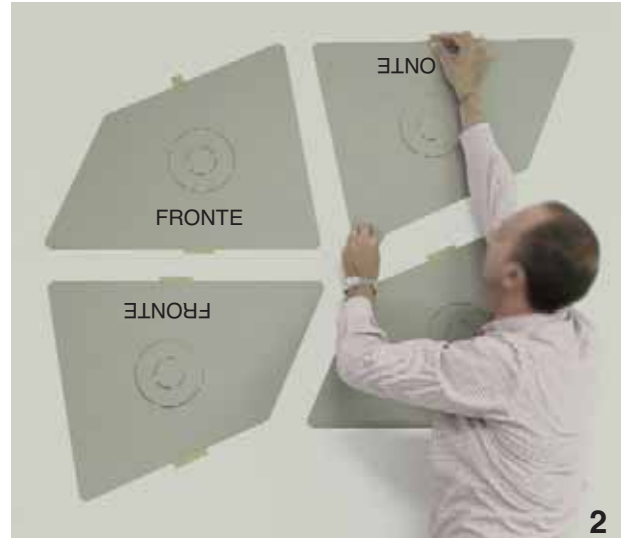

# FLAP / MAXIFLAP LED

design Alberto Meda, Francesco Meda  
Snowsound® technology by Caimi Brevetti

Codice  
Code

Colore  
Colour

Prezzo  
Price

Descrizione  
Description

7FL110

Led (14,4 W - 3000° K) per pannelli Flap (cod. 7F1007-XXXX) e Maxiflap (cod. 7F2007-XXXX) completo di alimentatore.

Led (14,4 W - 3000° K) for Flap (cod. 7F1007-XXXX) and Maxiflap (cod. 7F2007-XXXX) panels, complete with power supply.

Led (14,4 W - 3000° K) pour panneaux Flap (réf. 7F1007-XXXX) et Maxiflap (réf. 7F2007-XXXX) avec alimentation.

Led (14,4 W - 3000° K) para paneles Flap (cod. 7F1007-XXXX) y Maxiflap (cod. 7F2007-XXXX) se completa con la fuente de alimentación.

LED-Beleuchtung (14,4 W - 3000° K) für die Paneele Flap (Art. Nr. 7F1007-XXXX) und Maxiflap (Art. Nr. 7F2007-XXXX), inklusive Stromzufuhr.

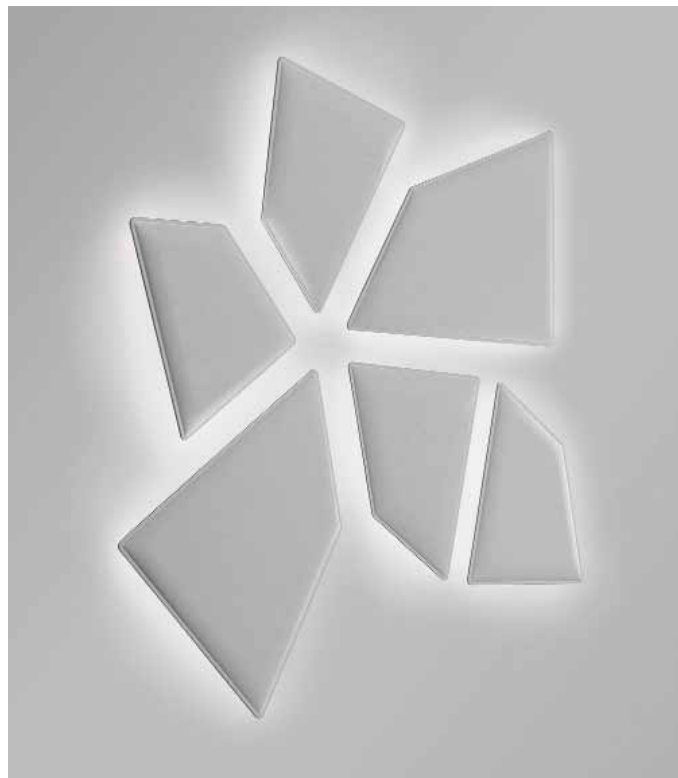
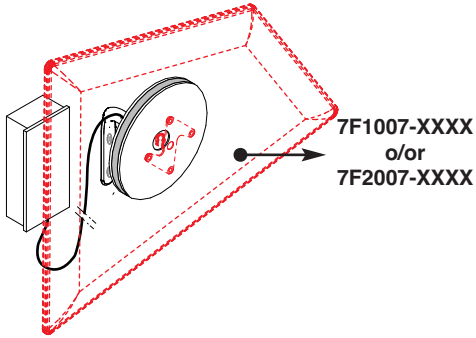
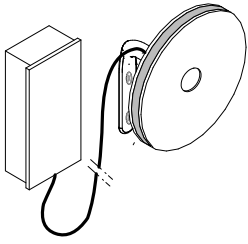

# FLAP CEILING LED

design Alberto Meda, Francesco Meda  
Snowsound® technology by Caimi Brevetti

**Codice**  
**Code**  
**7FCL120**

**Colore**  
**Colour**

**Prezzo**  
**Price**

**Descrizione**  
**Description**

Coppia di profili con Led orientabili (2 x 19 W - 3000° K) per 1 telaio Flap cod. 7FC2024-C o 7FC1024-C.

Pair of profiles with adjustable Led (2 x 19 W - 3000° K) for one Flap frame (product code 7FC2024-C or C-7FC1024).

Paire de profils avec Led orientables (2 x 19 W - 3000° K) pour 1 structure Flap réf. 7FC2024-C ou 7FC1024-C.

Set de 2 perfiles con Led ajustables (2 x 19 W - 3000° K) para 1 estructurar Flap cod. 7FC2024-C o 7FC1024-C.

Ein Paar Profile mit justierbaren LED (2 x 19 W - 3000° K) für eine Flap-Halterung zur Deckenmontage (Art. Nr. 7FC2024-C oder C-7FC1024)

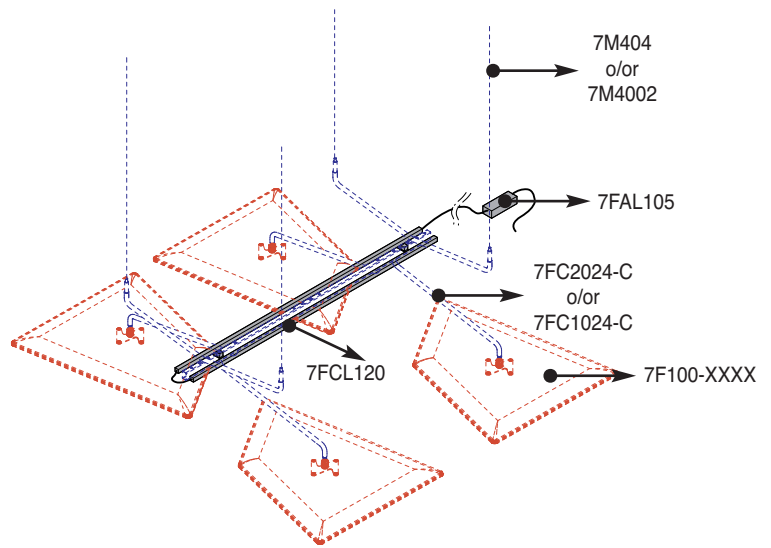
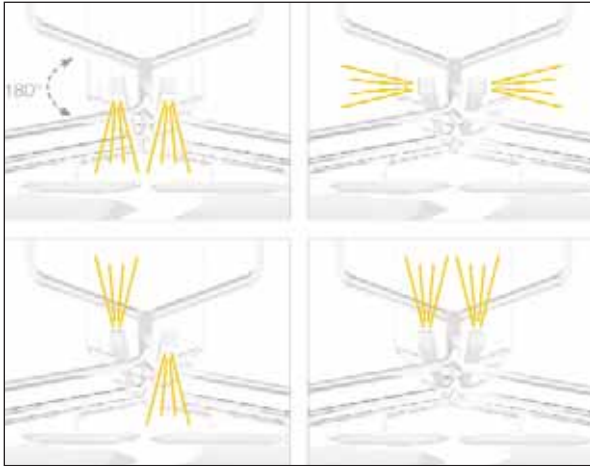
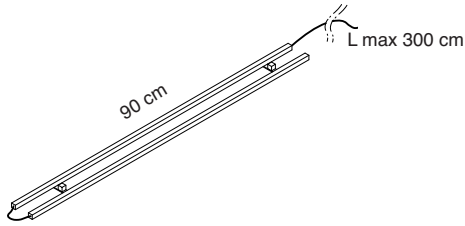

**7FAL105**

Alimentatore per max due coppie di profili per Led cod. 7FCL120. Completo di carter di copertura in alluminio.

Power supply for up to two pairs of profiles for Led cod. 7FCL120. Complete with aluminum cover

Fuente de alimentación para más de dos sets de perfiles para Led código 7FCL120, se completa con un embellecedor de aluminio

Unidad de alimentación para máximo 2 pares de perfiles Led cod. 7FCL120. Completo de carter de cobertura en aluminio.

Stromzufuhr für bis zu 2 Paar Profile für LED Art. Nr. 7FCL120. Inklusive Abdeckung aus Aluminium.

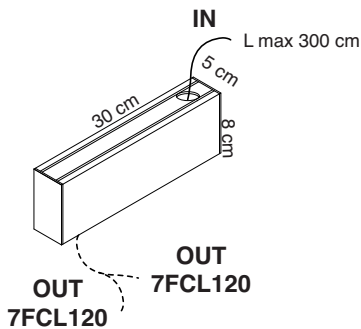



# FLAP TOTEM / CEILING

design Alberto Meda, Francesco Meda  
Snowsound® technology by Caimi Brevetti

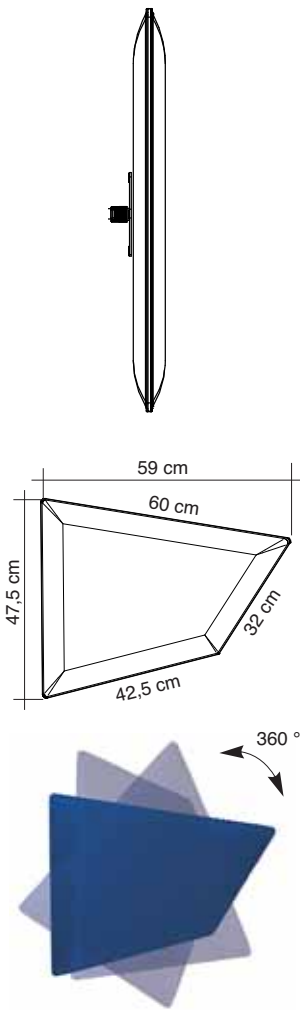

Colore Colour	Codice / Code Prezzo / Price	Colore Colour	Codice / Code Prezzo / Price
Bianco White Blanc 0001	<b>7F100-0001</b> cad/each	Arancione Orange Orange 4030	<b>7F100-4030</b> cad/each
2 pz. per scatola / Box of 2 pcs / Condit. à 2 pcs 2 pz. por embalaje / Verpackungseinheit 2 St.		2 pz. per scatola / Box of 2 pcs / Condit. à 2 pcs 2 pz. por embalaje / Verpackungseinheit 2 St.	
Grigio argento Silver grey Gris argenté 8004	<b>7F100-8004</b> cad/each	Rosso Red Rouge 4027	<b>7F100-4027</b> cad/each
2 pz. per scatola / Box of 2 pcs / Condit. à 2 pcs 2 pz. por embalaje / Verpackungseinheit 2 St.		2 pz. per scatola / Box of 2 pcs / Condit. à 2 pcs 2 pz. por embalaje / Verpackungseinheit 2 St.	
Grigio scuro Dark grey Gris foncé 8007	<b>7F100-8007</b> cad/each	Verde chiaro Light green Vert clair 7004	<b>7F100-7004</b> cad/each
2 pz. per scatola / Box of 2 pcs / Condit. à 2 pcs 2 pz. por embalaje / Verpackungseinheit 2 St.		2 pz. per scatola / Box of 2 pcs / Condit. à 2 pcs 2 pz. por embalaje / Verpackungseinheit 2 St.	
Beige Beige Beige 1008	<b>7F100-1008</b> cad/each	Verde Green Vert 7013	<b>7F100-7013</b> cad/each
2 pz. per scatola / Box of 2 pcs / Condit. à 2 pcs 2 pz. por embalaje / Verpackungseinheit 2 St.		2 pz. per scatola / Box of 2 pcs / Condit. à 2 pcs 2 pz. por embalaje / Verpackungseinheit 2 St.	
Tortora Dove-grey Taupe 2005	<b>7F100-2005</b> cad/each	Blu Blue Bleu 6071	<b>7F100-6071</b> cad/each
2 pz. per scatola / Box of 2 pcs / Condit. à 2 pcs 2 pz. por embalaje / Verpackungseinheit 2 St.		2 pz. per scatola / Box of 2 pcs / Condit. à 2 pcs 2 pz. por embalaje / Verpackungseinheit 2 St.	
Giallo Yellow Jaune 3008	<b>7F100-3008</b> cad/each	Nero Black Noir 8033	<b>7F100-8033</b> cad/each
2 pz. per scatola / Box of 2 pcs / Condit. à 2 pcs 2 pz. por embalaje / Verpackungseinheit 2 St.		2 pz. per scatola / Box of 2 pcs / Condit. à 2 pcs 2 pz. por embalaje / Verpackungseinheit 2 St.	

## Descrizione

### Description

Pannello con imbottitura interna in poliester a **densità variabile** Snowsound® Technology. Rivestimento esterno in tessuto di poliester Trevira CS®. Completo di piastra e snodo in acciaio cromato per fissaggio ai telai a soffitto cod. 7FC1024-C e 7FC2024-C e ai totem cod. 7FT3006-BO e 7FT3006-N. Il pannello è inclinabile in tutte le direzioni e può ruotare di 360°.

Panel with polyester internal padding with Snowsound® Technology **variable density**. Polyester covering in Trevira CS® fabric. Equipped with plate and chrome-plated joint for fixing to frames hanging from the ceiling code 7FC1024-C and 7FC2024-C and to free-standing supports code 7FT3006-BO and 7FT3006-N. The panel can be tilted in any direction and can rotate 360 degrees.

Panneau avec rembourrage interne en polyester à **densité variable** Snowsound® Technology. Revêtement externe en tissu de polyester Trevira CS®. Fourni avec plaque et articulation en acier chromé pour la fixation des châssis au plafond code 7FC1024-C et 7FC2024-C, et aux totems code 7FT3006-BO et 7FT3006-N. Le panneau peut être incliné dans toutes les directions et pivoter sur 360°.

Panel con acolchado interior de poliéster de **densidad variable** Snowsound® Technology. Revestimiento exterior en tejido de poliéster Trevira CS®. Completo con placa y articulación de acero cromado para fijación al bastidor al techo 7FC1024-C et 7FC2024-C y a los totem FT3006-BO et 7FT3006-N. El panel es inclinable en todas direcciones y puede rotar a 360°.

Akustikpaneel, innen mit Polyester in **unterschiedlicher Dichte** unter Verwendung der Snowsound®-Technologie gepolstert. Oberfläche aus Polyesterstoff Trevira CS®. Ausgestattet mit einer Montageplatte und einem verchromten Gelenk zur Befestigung an Rahmenkonstruktionen zur Deckenabhängung Art.Nr. 7FC1024-C und 7FC2024-C bzw. zur Befestigung and Standsäulen Art.Nr. 7FT3006-BO und 7FT3006-N. Das Paneel kann in jede Richtung geneigt und um 360 Grad gedreht werden.



# FLAP TOTEM

design Alberto Meda, Francesco Meda  
Snowsound® technology by Caimi Brevetti

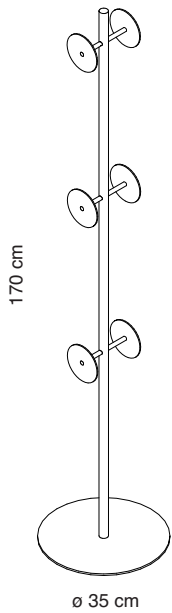

Codice Code	Colore Colour	Prezzo Price	Descrizione Description
<b>7FT3006-BO</b>	Bianco opaco / Cromato Mat white / Chrome-plated Blanc mat / Chromé Blanco mate / Cromado Matweiß / Verchromtem		Struttura in acciaio cromato con base in acciaio verniciato con polveri epossidiche colore bianco o nero per il montaggio di <b>6</b> pannelli Flap 7F100-XXXX (XXXX = Variante colore).  Structure in chrome-plated steel with mat white or black powder-coated steel base to mount <b>6</b> Flap panels code 7F100-XXXX (XXXX = colour option).  Structure en acier chromé avec base en acier peint époxy blanc mat ou noir pour l'accrochage de <b>6</b> panneaux Flap 7F100-XXXX (XXXX = option couleur)
<b>7FT3006-N</b>	Nero / Cromato Black / Chrome-plated Noir / Chromé Negro / Cromado Schwarz / Verchromtem		Estructura de acero cromado con base de acero recubierto epoxi blanco mate o negro para el montaje de <b>6</b> panels Flap 7F100-XXXX (XXXX = Variante color).  Standsäule aus verchromtem Stahl mit Standfuß aus pulverbeschichtetem Stahl, matweiß oder schwarz von <b>6</b> Flap-Paneelen Art. 7F100-XXXX (XXXX = Farbvariante).

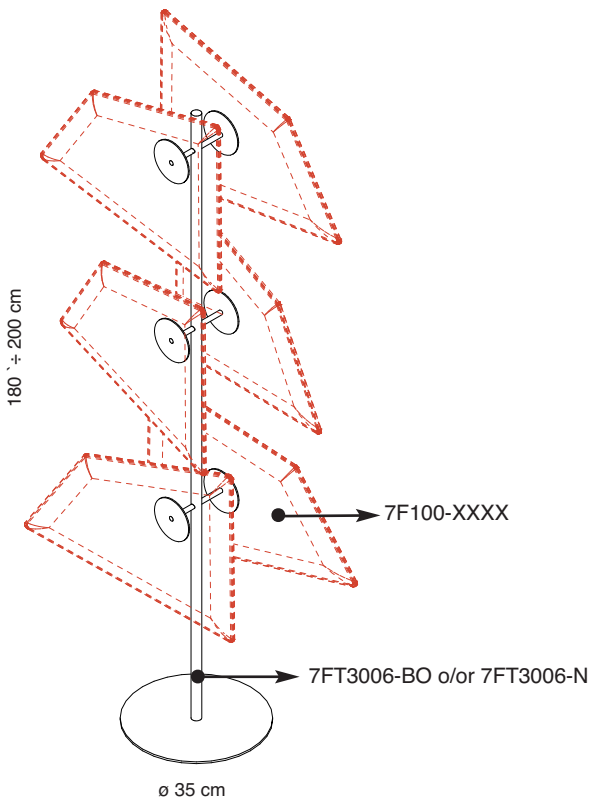

Ingombro massimo 70x70 cm  
Max overall dimension 70x70 cm



# FLAP CEILING

design Alberto Meda, Francesco Meda  
Snowsound® technology by Caimi Brevetti

Codice Code	Colore Colour	Prezzo Price	Descrizione Description
<b>7FC2024-C</b>	Cromato Chrome-plated Chromé Cromado Verchromt		<p>Telaio in acciaio cromato per appendimento a soffitto di 4 pannelli Flap cod. 7F100-XXXX (XXXX = Variante colore). Telaio singolo, NON MODULARE. Per utilizzo in composizioni singole.</p> <p>Chrome-plated frame for fixing to the ceiling four Flap panels code 7F100-XXX (XXXX = colour option). Single frame, NOT MODULAR. For use in single structures.</p> <p>Châssis en acier chromé pour l'accrochage au plafond de 4 panneaux Flap code 7F100-XXXX (XXXX = option couleur). Châssis simple, NON MODULABLE. Pour compositions simples.</p> <p>Bastidor de acero cromado para fijación al techo de 4 paneles Flap cod. 7F100-XXXX (XXXX = Variante color). Bastidor solo, NO MODULAR, para utilización con composiciones individuales.</p> <p>Verchromte Halterung zur Deckenmontage von vier Flap Paneelen Art.Nr. 7F100-XXX (XXXX = Farbvariante). Einzelne Halterung, NICHT MODULAR. Zur Verwendung in Einzelkonstruktionen.</p>

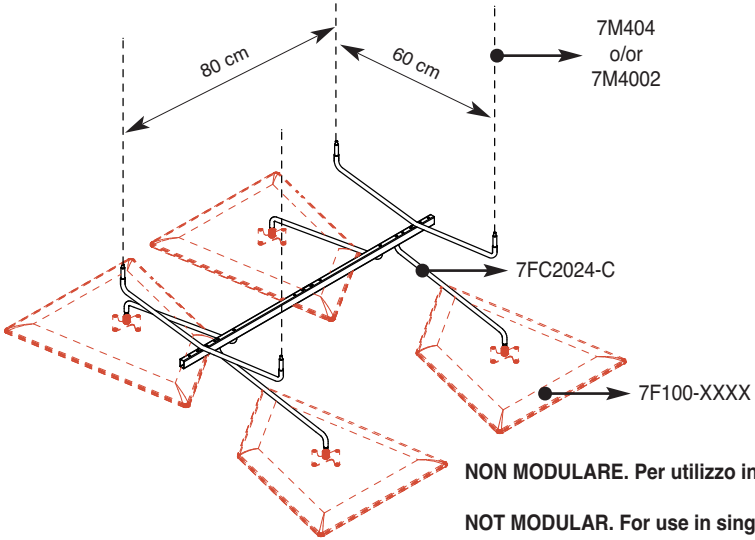
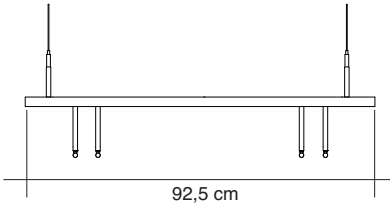
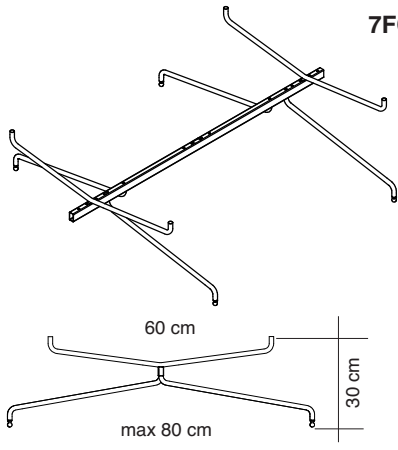

**NON MODULARE. Per utilizzo in composizioni singole.**  
**NOT MODULAR. For use in single structures.**

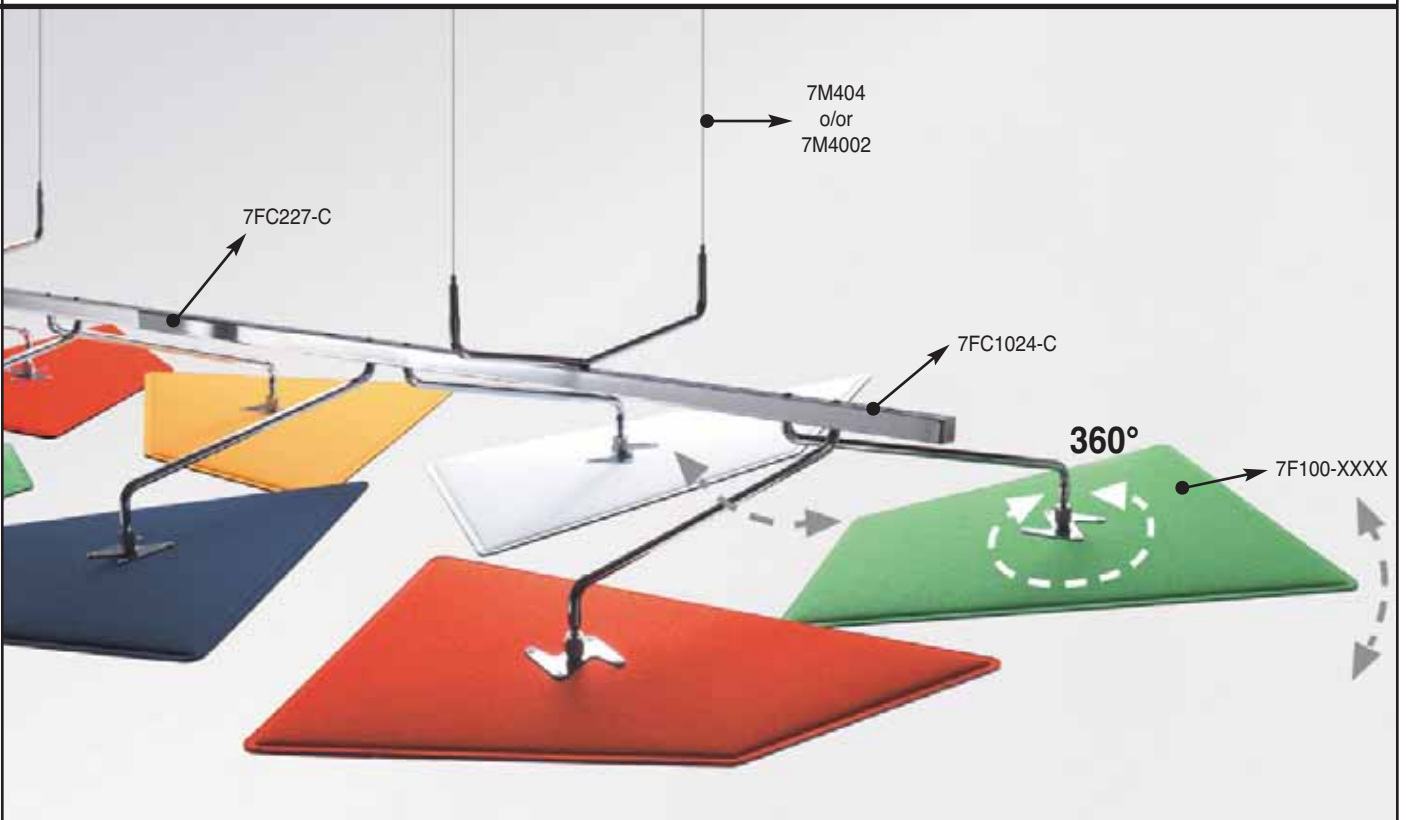

# FLAP CEILING

design Alberto Meda, Francesco Meda  
Snowsound® technology by Caimi Brevetti

	Codice Code	Colore Colour	Prezzo Price	Descrizione Description
	<b>7FC1024-C</b>	Cromato Chrome-plated Chromé Cromado Verchromt		<p>Telaio in acciaio cromato per appendimento a soffitto di 4 pannelli Flap cod. 7F100-XXXX (XXXX = Variante colore). Telaio MODULARE, per utilizzo in composizioni collegate in linea mediate giunto lineare 7FC227-C.</p> <p>Chrome-plated frame for fixing to the ceiling four Flap panels code 7F100-XXX (XXXX = colour option). MODULAR frame for use with in line compositions linked through linear joint code 7FC227-C</p> <p>Châssis en acier chromé pour l'accrochage au plafond de 4 panneaux Flap code 7F100-XXXX (XXXX = option couleur). Châssis MODULABLE. Pour compositions linéaires avec joint linéaire code 7FC227-C</p> <p>Bastidor de acero cromado para fijación al techo de 4 paneles Flap cod. 7F100-XXXX (XXXX = Variante color). Bastidor MODULAR para utilización en composiciones vinculadas en línea con enganche lineal 7FC227-C.</p> <p>Verchromte Halterung zur Deckenmontage von vier Flap Paneelen Art.Nr. 7F100-XXX (XXXX = Farbvariante). MODULARE Halterung zur Verwendung in zusammengesetzten Konstruktionen, die mit dem Reihenverbinder Art. Nr. 7FC227-C verbunden werden.</p>
	<b>7FC227-C</b>	Cromato Chrome-plated Chromé Cromado Verchromt		<p>Giunto lineare in acciaio cromato per telai da 4 pannelli Flap cod. 7FC1024-C.</p> <p>Chrome-plated joint for for four Flap panels frame code 7FC1024-C.</p> <p>Joint linéaire en acier chromé pour châssis 4 panneaux Flap code 7FC1024-C.</p> <p>Enganche lineal de acero cromado para bastidores de 4 paneles Flap cod 7FC1024-C.</p> <p>Reihenverbinder für Halterung 7FC1024-C.</p>

# FLAP CEILING

design Michele De Lucchi  
Snowsound® technology by Caimi Brevetti

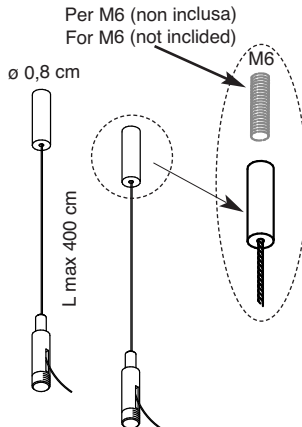
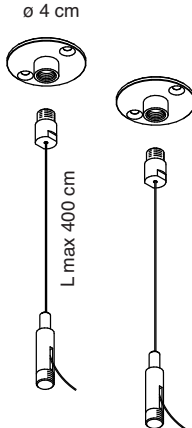
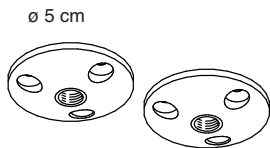
	Codice Code	Colore Colour	Prezzo Price	Descrizione Description
 <p>Per M6 (non inclusa) For M6 (not included)</p> <p>ø 0,8 cm</p> <p>L max 400 cm</p> <p>M6</p>	<p><b>7M404</b></p>	<p>Cromato Chrome-plated Chromé Cromado Verchromt</p>		<p>Kit per fissaggio a soffitto dei telai Flap 7FC2024-C e 7FC1024-C composto da: 2 attacchi a soffitto filettati M6 - 2 cavi in acciaio - 2 attacchi a telaio</p> <p>Kit for the ceiling fixing of the frames Flap 7FC2024-C e 7FC1024-C composed of: 2 ceiling hanging threaded M6 - 2 steel cables - 2 hangings.</p> <p>Kit d'accrochage au plafond de châssis Flap 7FC2024-C e 7FC1024-C composé de: 2 accrochages au plafond filetés M6 - 2 câbles en acier - 2 accrochages.</p> <p>Kit para el montaje al techo de bastidor Flap 7FC2024-C e 7FC1024-C compuesto por: 2 enganches al techo roscados M6 - 2 cables de acero, 2 enganches.</p> <p>Set für die Deckenbefestigung der netzartigen Struktur Flap 7FC2024-C e 7FC1024-C, bestehend aus: 2 Deckenbefestigungen für Gewinde M6, 2 Stahlseile, 2 Befestigungen.</p>
 <p>ø 4 cm</p> <p>L max 400 cm</p>	<p><b>7M4002</b></p>	<p>Cromato Chrome-plated Chromé Cromado Verchromt</p>		<p>Kit per fissaggio a soffitto dei telai Flap 7FC2024-C e 7FC1024-C composto da: 2 piastre a soffitto a 2 fori - 2 cavi in acciaio - 2 attacchi a telaio</p> <p>Kit for the ceiling fixing of frames Flap 7FC2024-C e 7FC1024-C composed of: 2 ceiling plates with 2 holes - 2 steel cables - 2 hangings</p> <p>Kit d'accrochage au plafond de châssis Flap 7FC2024-C e 7FC1024-C composé de: 2 plaques pour plafond à 2 trous - 2 câbles en acier - 2 accrochages</p> <p>Kit para el montaje al techo de bastidor Flap 7FC2024-C e 7FC1024-C compuesto por: 2 placas de techo con 2 huecos - 2 cables de acero, 2 enganches</p> <p>Set für die Deckenbefestigung der netzartigen Struktur Flap 7FC2024-C e 7FC1024-C, bestehend aus: 2 Deckenmontageplatten mit 2 Befestigungsbohrungen, 2 Stahlseile, 2 Befestigungen</p>
 <p>ø 5 cm</p>	<p><b>7M403</b> <b>OPZIONALE</b> <b>OPTIONAL</b></p>	<p>Cromato Chrome-plated Chromé Cromado Verchromt</p>		<p>Coppia piastre a soffitto a 3 fori. Possono essere acquistate separatamente e utilizzati per sostituire gli attacchi a 2 fori in tutti i kit di fissaggio a soffitto. ARTICOLO OPZIONALE.</p> <p>Pair of ceiling plates with 3 holes. Can be purchased separately and be used to replace the plates with 2 holes in all ceiling hanging kits. OPTIONAL ITEM.</p> <p>Paire de plaques pour plafond à 3 trous. Il est possible de les acheter séparément et les utiliser pour remplacer les accroches à 2 trous dans tous les kits d'accrochage au plafond. ARTICLE OPTIONNEL</p> <p>Par de placas de techo con 3 huecos. Se pueden comprar separatamente y ser utilizadas para reemplazar los enganches a 2 huecos en todos los kit de montaje al techo. ARTÍCULO OPCIONAL</p> <p>2 Deckenmontageplatten mit 3 Befestigungsbohrungen. Diese können separat gekauft und an Stelle der Befestigungen mit 2 Bohrungen in allen Deckenbefestigungs-Sets verwendet werden. OPTIONAL ERHALTLICH</p>

# FLAP CEILING

design Alberto Meda, Francesco Meda  
Snowsound® technology by Caimi Brevetti

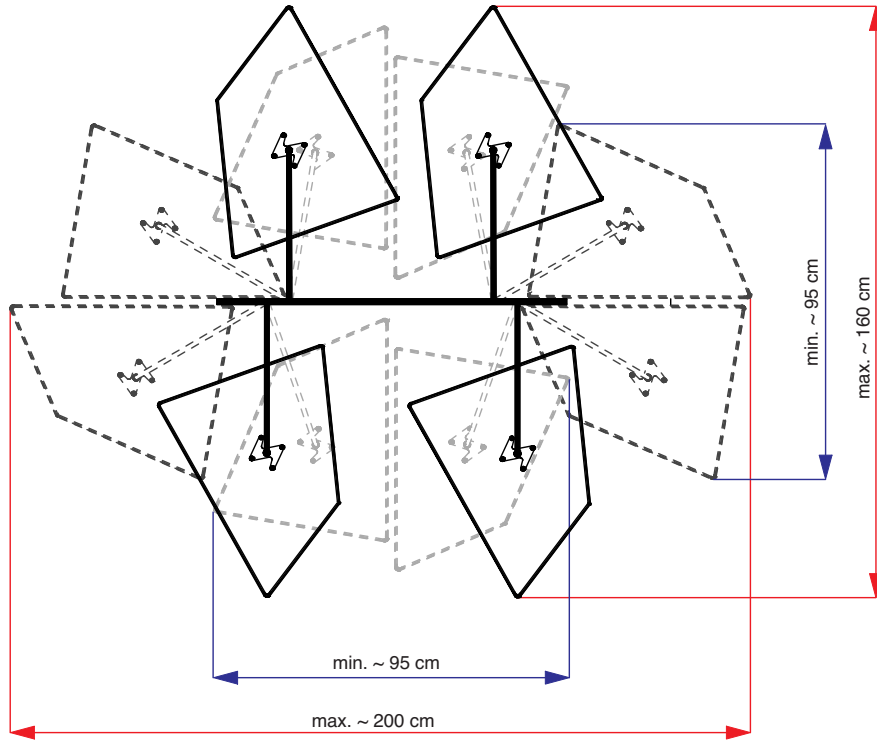

code  
7FC2024-C

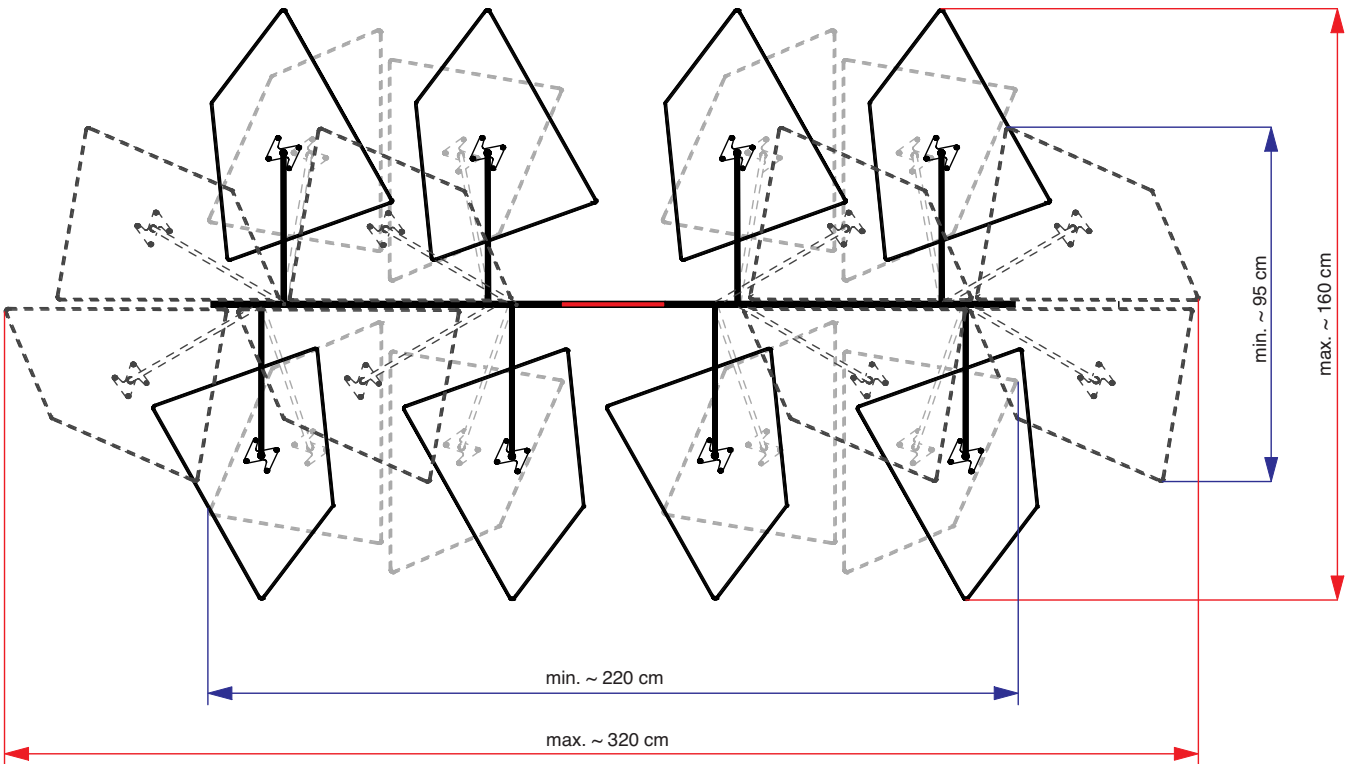

code  
7FC1024-C

+

code  
7FC227-C

+

code  
7FC1024-C

# V-FLAP

design Alberto Meda, Francesco Meda  
Snowsound® technology by Caimi Brevetti

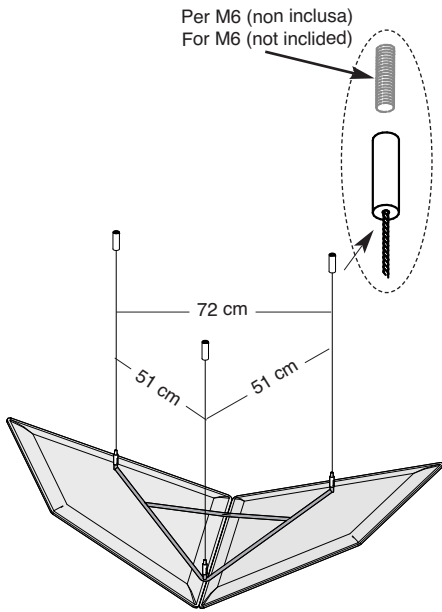

Colore Colour	Codice / Code Prezzo / Price	Colore Colour	Codice / Code Prezzo / Price
Bianco White Blanc 0001	7FV3006-0001	Arancione Orange Orange 4030	7FV3006-4030
Grigio argento Silver grey Gris argenté 8004	7FV3006-8004	Rosso Red Rouge 4027	7FV3006-4027
Grigio scuro Dark grey Gris foncté 8007	7FV3006-8007	Verde chiaro Light green Vert clair 7004	7FV3006-7004
Beige Beige Beige 1008	7FV3006-1008	Verde Green Vert 7013	7FV3006-7013
Tortora Dove-grey Taupe 2005	7FV3006-2005	Blu Blue Bleu 6071	7FV3006-6071
Giallo Yellow Jaune 3008	7FV3006-3008	Nero Black Noir 8033	7FV3006-8033

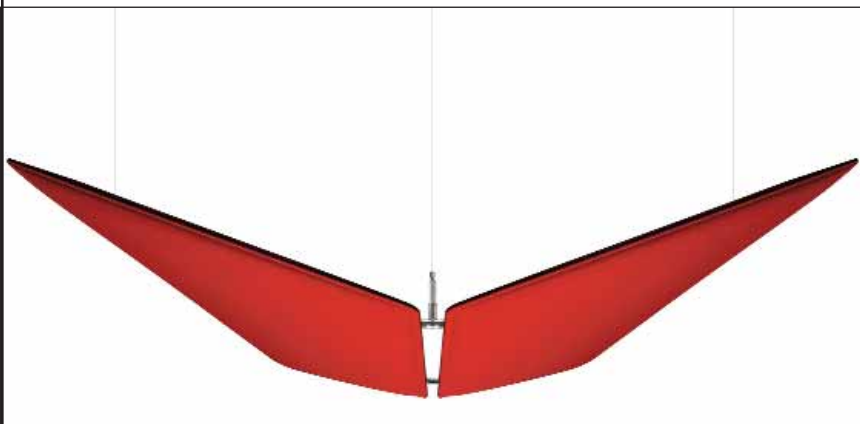

## Descrizione

### Description

Pannelli con imbottitura interna in poliester a **densità variabile** Snowsound® Technology. Rivestimento esterno in tessuto di poliester Trevira CS®. Completati di struttura in acciaio cromato e kit per fissaggio a soffitto composto da: 3 attacchi a soffitto filettati M6 - 3 cavi in acciaio - 3 attacchi per telaio.

Panel with polyester internal padding with Snowsound® Technology **variable density**. Polyester covering in Trevira CS® fabric. Equipped with chrome-plated steel frame and Kit for the ceiling fixing composed of: 3 ceiling hanging threaded M6, 3 steel cables, 3 hangings for frame.

Panneau avec rembourrage interne en polyester à **densité variable** Snowsound® Technology. Revêtement externe en tissu de polyester Trevira CS®. Fourni avec structure en acier chromé et kit d'accrochage au plafond composé de: 3 accrochages au plafond filetés M6 - 3 câbles en acier - 3 accrochages pour cadre

Panel con acolchado interior de poliéster de **densidad variable** Snowsound® Technology. Revestimiento exterior en tejido de poliéster Trevira CS®. Completo de estructura de acero cromado y kit para el montaje al techo compuesto por: 3 enganches al techo roscados M6 - 3 cables de acero - 3 enganches para bastidor.

Panel mit Polyester-Füllmaterial von **unterschiedlicher Dichte** Snowsound® Technology. Polyester-Bezug aus Trevira CS®-Material. Ausgestattet mit Gestell aus verchromtem Stahl und Set für die Deckenbefestigung bestehend aus: 3 Deckenbefestigungen für Gewinde M6, 3 Stahlseile, 3 Befestigungen für den Rahmen.

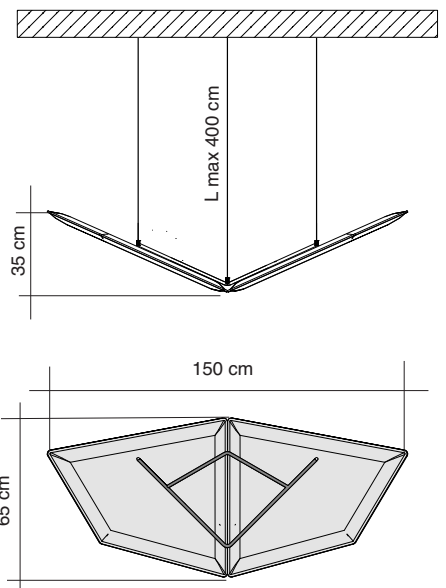



# V-FLAP

design Alberto Meda, Francesco Meda  
Snowsound® technology by Caimi Brevetti

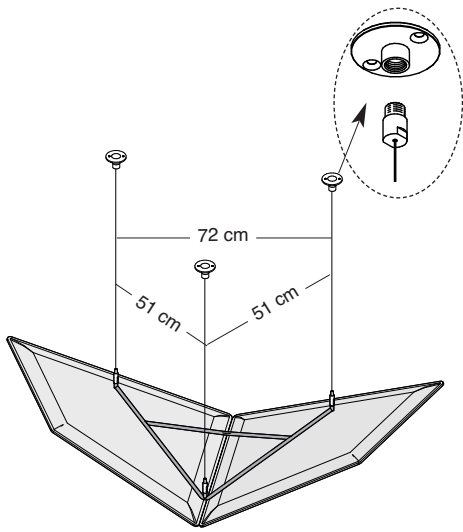

Colore Colour	Codice / Code Prezzo / Price	Colore Colour	Codice / Code Prezzo / Price
Bianco White Blanc 0001	7FV3002-0001	Arancione Orange Orange 4030	7FV3002-4030
Grigio argento Silver grey Gris argenté 8004	7FV3002-8004	Rosso Red Rouge 4027	7FV3002-4027
Grigio scuro Dark grey Gris foncté 8007	7FV3002-8007	Verde chiaro Light green Vert clair 7004	7FV3002-7004
Beige Beige Beige 1008	7FV3002-1008	Verde Green Vert 7013	7FV3002-7013
Tortora Dove-grey Taupe 2005	7FV3002-2005	Blu Blue Bleu 6071	7FV3002-6071
Giallo Yellow Jaune 3008	7FV3002-3008	Nero Black Noir 8033	7FV3002-8033

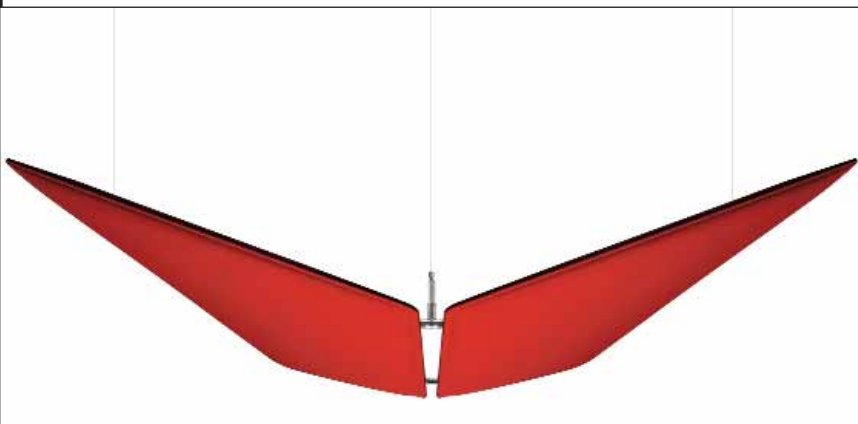

## Descrizione Description

Pannelli con imbottitura interna in poliester a **densità variabile** Snowsound® Technology. Rivestimento esterno in tessuto di poliester Trevira CS®. Completi di struttura in acciaio cromato e kit per fissaggio a soffitto composto da: 3 piastre a soffitto a 2 fori - 3 cavi in acciaio - 3 attacchi per telaio.

Panel with polyester internal padding with Snowsound® Technology **variable density**. Polyester covering in Trevira CS® fabric. Equipped with chrome-plated steelframe and Kit for the ceiling fixing composed of: 2 ceiling plates with 3 holes, 3 steel cables, 3 hangings for frame.

Panneau avec rembourrage interne en polyester à **densité variable** Snowsound® Technology. Revêtement externe en tissu de polyester Trevira CS®. Fourni avec structure en acier chromé et kit d'accrochage au plafond composé de: 3 plaques pour plafond à 2 trous - 3 câbles en acier - 3 accrochages pour cadre

Panel con acolchado interior de poliéster de **densidad variable** Snowsound® Technology. Revestimiento exterior en tejido de poliéster Trevira CS®. Completo de estructura de acero cromado y kit para el montaje al techo compuesto por: 3 placas de techo con 2 huecos - 3 cables de acero - 3 enganches para bastidor.

Panel mit Polyester-Füllmaterial von **unterschiedlicher Dichte** Snowsound® Technology. Polyester-Bezug aus Trevira CS®-Material. Ausgestattet mit Gestell aus verchromtem Stahl und Set für die Deckenbefestigung bestehend aus: 3 Deckenmontageplatten mit 2 Befestigungsbohrungen, 3 Stahlseile, 3 Befestigungen für den Rahmen.

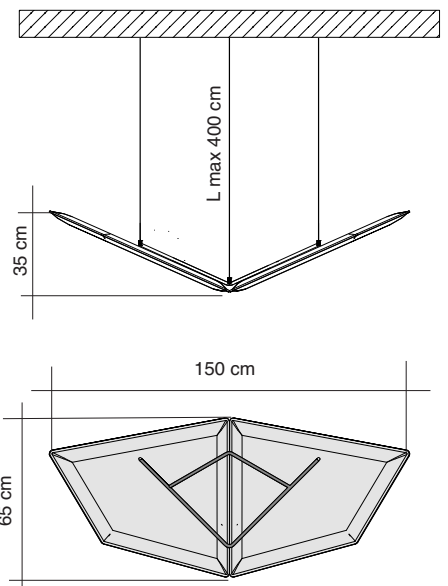

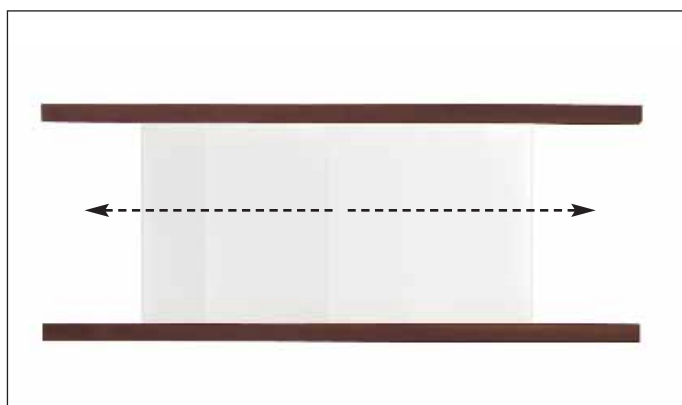

**Descrizione**  
**Description**

Pannello con imbottitura interna in poliestere a **densità variabile** Snowsound® Technology. Rivestimento esterno in tessuto di poliestere Trevira CS®.

Panel with polyester internal padding with Snowsound® Technology **variable density**. Polyester covering in Trevira CS® fabric.

Panneau avec rembourrage interne en polyester à **densité variable** Snowsound® Technology. Revêtement externe en tissu de polyester Trevira CS®.

Panel con acolchado interior de poliéster de **densidad variable** Snowsound® Technology. Revestimiento exterior en tejido de poliéster Trevira CS®.

Panel mit Polyester-Füllmaterial von **unterschiedlicher Dichte** Snowsound® Technology. Polyester-Bezug aus Trevira CS®-Material.

# PRESIDENT ALUMINIUM/WOOD

design Philippe Nigro  
Snowsound® technology by Caimi Brevetti

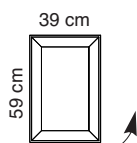

L. 39 cm

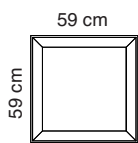

L. 59 cm

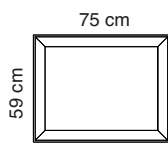

L. 75 cm

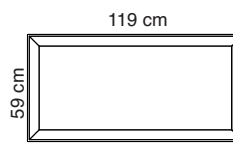

L. 119 cm

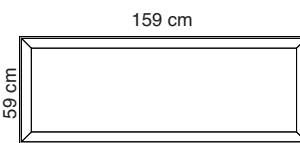

L. 159 cm

	Codice/Code Prezzo/Price	Codice/Code Prezzo/Price	Codice/Code Prezzo/Price	Codice/Code Prezzo/Price	Codice/Code Prezzo/Price
Bianco White Blanc <b>0001</b>	<b>7P0406-0001</b>	<b>7P0606-0001</b>	<b>7P0806-0001</b>	<b>7P1206-0001</b>	<b>7P1606-0001</b>
Grigio argento Silver grey Gris argenté <b>8004</b>	<b>7P0406-8004</b>	<b>7P0606-8004</b>	<b>7P0806-8004</b>	<b>7P1206-8004</b>	<b>7P1606-8004</b>
Grigio scuro Dark grey Gris foncé <b>8007</b>	<b>7P0406-8007</b>	<b>7P0606-8007</b>	<b>7P0806-8007</b>	<b>7P1206-8007</b>	<b>7P1606-8007</b>
Beige Beige Beige <b>1008</b>	<b>7P0406-1008</b>	<b>7P0606-1008</b>	<b>7P0806-1008</b>	<b>7P1206-1008</b>	<b>7P1606-1008</b>
Tortora Dove-grey Taupe <b>2005</b>	<b>7P0406-2005</b>	<b>7P0606-2005</b>	<b>7P0806-2005</b>	<b>7P1206-2005</b>	<b>7P1606-2005</b>
Giallo Yellow Jaune <b>3008</b>	<b>7P0406-3008</b>	<b>7P0606-3008</b>	<b>7P0806-3008</b>	<b>7P1206-3008</b>	<b>7P1606-3008</b>
Arancione Orange Orange <b>4030</b>	<b>7P0406-4030</b>	<b>7P0606-4030</b>	<b>7P0806-4030</b>	<b>7P1206-4030</b>	<b>7P1606-4030</b>
Rosso Red Rouge <b>4027</b>	<b>7P0406-4027</b>	<b>7P0606-4027</b>	<b>7P0806-4027</b>	<b>7P1206-4027</b>	<b>7P1606-4027</b>
Verde chiaro Light green Vert clair <b>7004</b>	<b>7P0406-7004</b>	<b>7P0606-7004</b>	<b>7P0806-7004</b>	<b>7P1206-7004</b>	<b>7P1606-7004</b>
Verde Green Vert <b>7013</b>	<b>7P0406-7013</b>	<b>7P0606-7013</b>	<b>7P0806-7013</b>	<b>7P1206-7013</b>	<b>7P1606-7013</b>
Blu Blue Bleu <b>6071</b>	<b>7P0406-6071</b>	<b>7P0606-6071</b>	<b>7P0806-6071</b>	<b>7P1206-6071</b>	<b>7P1606-6071</b>
Nero Black Noir <b>8033</b>	<b>7P0406-8033</b>	<b>7P0606-8033</b>	<b>7P0806-8033</b>	<b>7P1206-8033</b>	<b>7P1606-8033</b>

# PRESIDENT ALUMINIUM

design Philippe Nigro  
Snowsound® technology by Caimi Brevetti

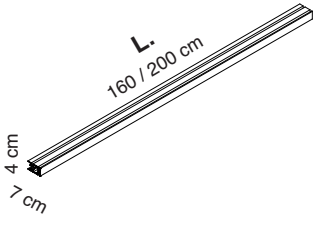
	Codice Code	Colore Colour	Prezzo Price	Descrizione Description
	<b>7PPA160-AL</b>	alluminio alluminio alluminio alluminio	<b>L. 160 cm</b>	<p>Profilo in alluminio lucido da applicare a parete (viti non incluse), completo di giunti per il collegamento in linea.</p> <p>Polished aluminum profile, to be fixed to the wall (screws not included), complete with joints for in-line connection.</p>
	<b>7PPA200-AL</b>	alluminio alluminio alluminio alluminio	<b>L. 200 cm</b>	<p>Profil en aluminium poli pour fixation murale (vis pas incluses), avec joints pour jonction en ligne</p> <p>Perfil en aluminio pulido, para fijar a la pared (tornillos no incluidos) se completa con juntas para conexión en línea.</p> <p>Profil aus poliertem Aluminium für die Wandmontage (Schrauben nicht inbegriffen), inklusive Verbindungsstücken für lineare Verbindungen.</p>

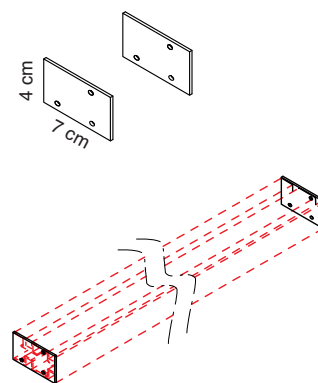
	<b>7PT2-AL</b>	alluminio alluminio alluminio alluminio	<b>1 coppia / 1 pair 1 paire / 1 pare 1 Paar</b>	<p>Coppia tappi terminali in alluminio lucido per profili in alluminio lucido cod. 7PPA160-AL / 7PPA200-AL.</p> <p>Pair of polished aluminum end caps for polished aluminum profiles (product code 7PPA160-AL / AL-7PPA200)</p> <p>Paire de caches en aluminium poli pour profils en aluminium poli réf. 7PPA160-AL / 7PPA200-AL</p> <p>Set de dos tapas finales en aluminio pulido para perfiles cod. 7PPA160-AL / 7PPA200-AL.</p> <p>Ein Paar Endstücke aus poliertem Aluminium für Profile aus poliertem Aluminium (Art. Nr. 7PPA160-AL / AL-7PPA200)</p>
------------------------------------------------------------------------------------	----------------	--------------------------------------------------	----------------------------------------------------------	--------------------------------------------------------------------------------------------------------------------------------------------------------------------------------------------------------------------------------------------------------------------------------------------------------------------------------------------------------------------------------------------------------------------------------------------------------------------------------------------------------------------------------------------------------------

## SCHEMA DI MONTAGGIO ASSEMBLY DIAGRAM

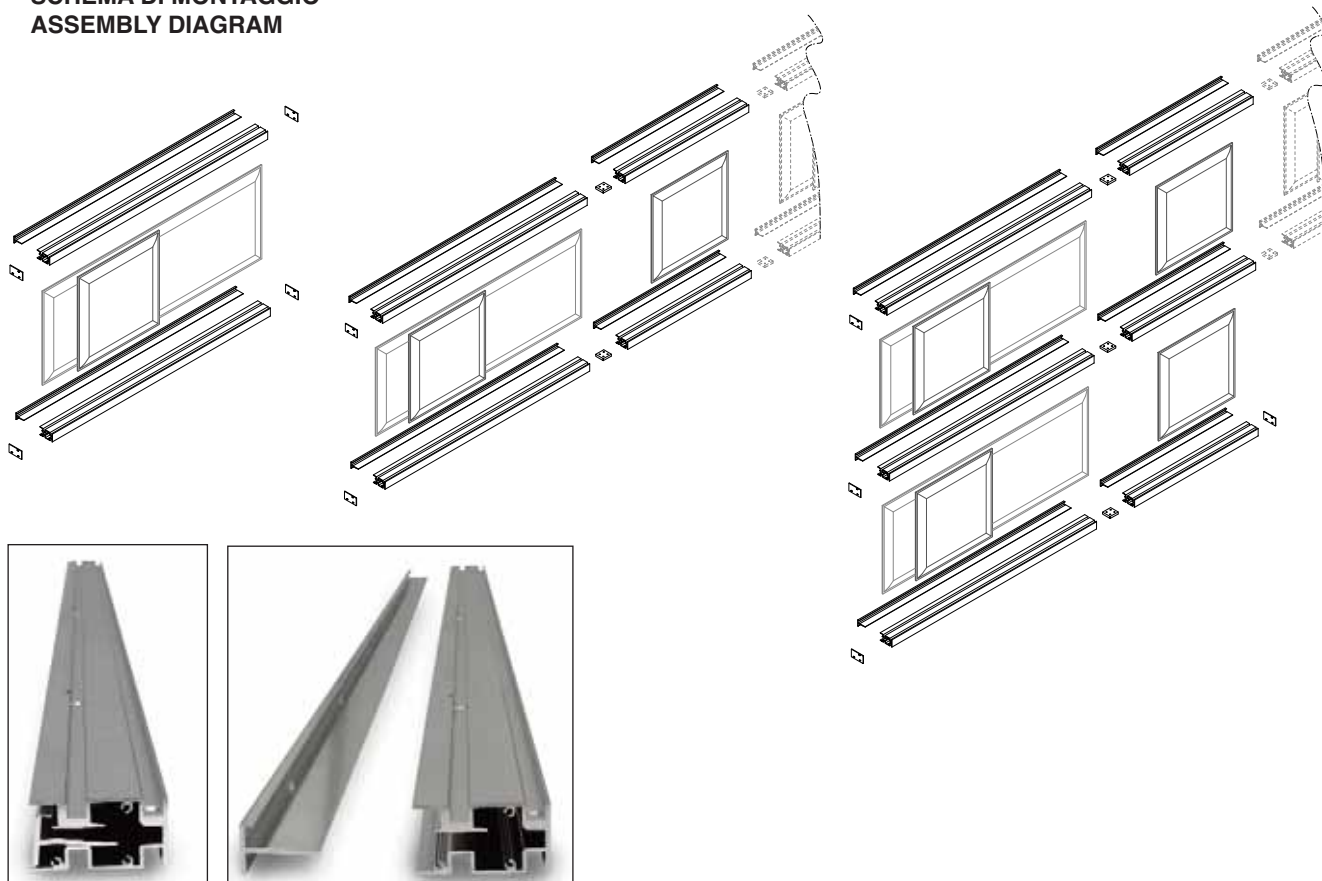

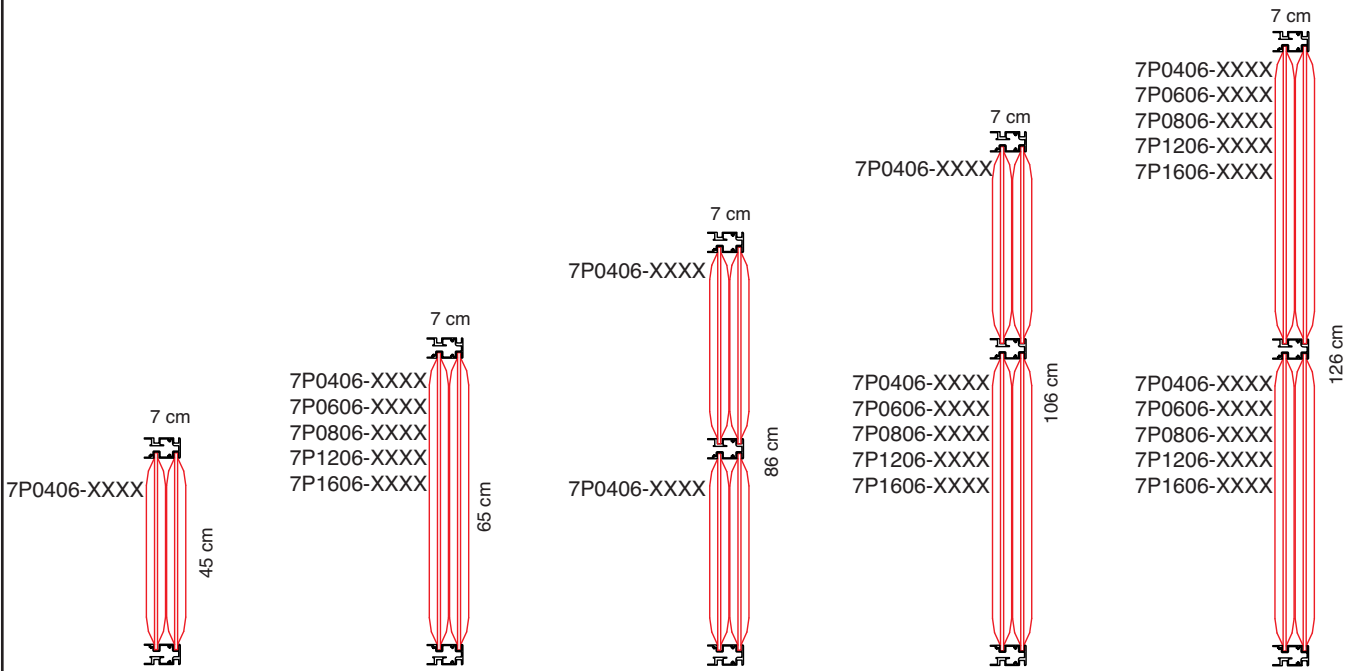

XXXX = Variante colore / XXXX = colour option / XXXX = option couleur / XXXX = opcion color / XXXX = Farbvariante

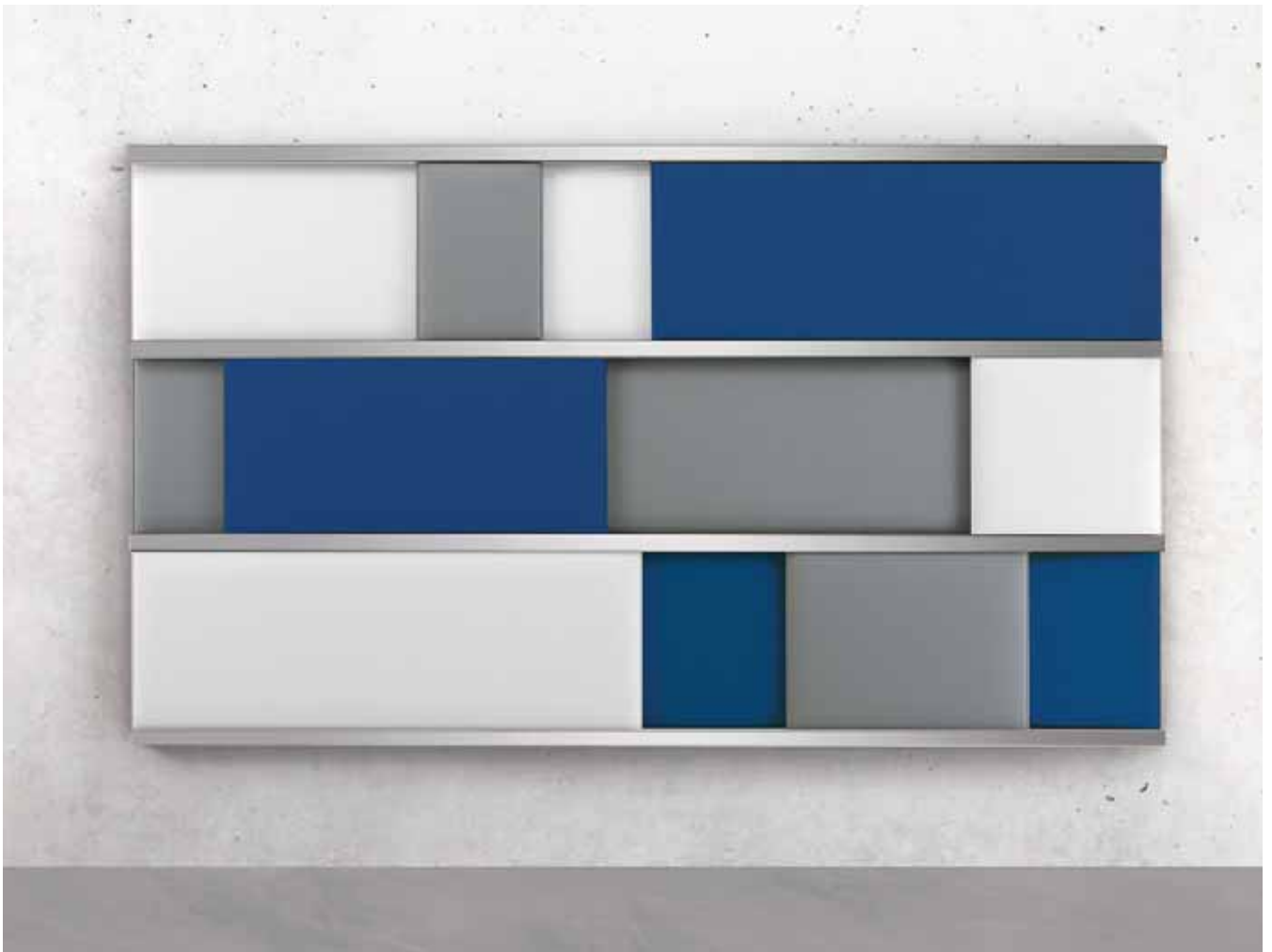

# PRESIDENT WOOD

design Philippe Nigro  
Snowsound® technology by Caimi Brevetti

Codice Code	Colore Colour	Prezzo Price	Descrizione Description
7PPL120-NS	legno legno legno legno legno	L. 120 cm	Profilo in legno tinto scuro da applicare a parete (viti non incluse), completo di giunti per il collegamento in linea. Dark stained wooden profile, to be fixed to the wall (screws not included), complete with joints for in-line connection.
7PPL160-NS	legno legno legno legno legno	L. 160 cm	Profil en bois foncé teint pour fixation murale (vis pas incluses), avec joints pour jonction en ligne. Perfil en madera manchada oscura para fijar a la pared (tornillos no incluidos) se completa con juntas para conexión en línea.
7PPL200-NS	legno legno legno legno legno	L. 200 cm	Profil aus dunkel gebeiztem Holz für die Wandmontage (Schrauben nicht inbegriffen), inklusive Verbindungsstücken für lineare Verbindungen.

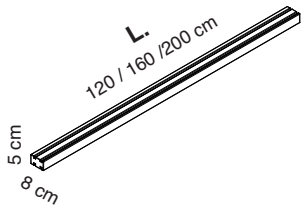

Codice Code	Colore Colour	Prezzo Price	Descrizione Description
7PT2-NM	Nero Micaceo Nero Micaceo Nero Micaceo Nero Micaceo Nero Micaceo	1 coppia / 1 pair 1 paire / 1 pare 1 Paar	Coppia tappi terminali in acciaio verniciato nero micaceo per profili in legno cod. 7PPL120-NS / 7PPL160-NS / 7PPL200-NS. Pair of micaceous finish epoxy powder-coated steel end caps for wooden profiles code 7PPL120-NS / 7PPL160-NS / 7PPL200-NS. Paire de caches en acier peint noir micacé pour profils en bois cod. 7PPL120-NS / 7PPL160-NS / 7PPL200-NS. Par de tapas finales en acero recubierto negro para perfiles en madeira cod. 7PPL120-NS / 7PPL160-NS / 7PPL200-NS. Ein Paar Endstücke aus pulverbeschichtetem Stahl für Holz-Profilen Art. 7PPL120-NS / 7PPL160-NS / 7PPL200-NS.

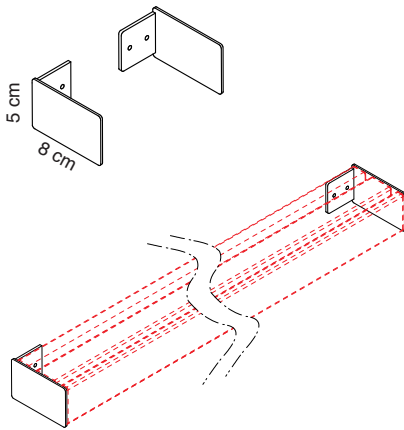

## SCHEMA DI MONTAGGIO ASSEMBLY DIAGRAM

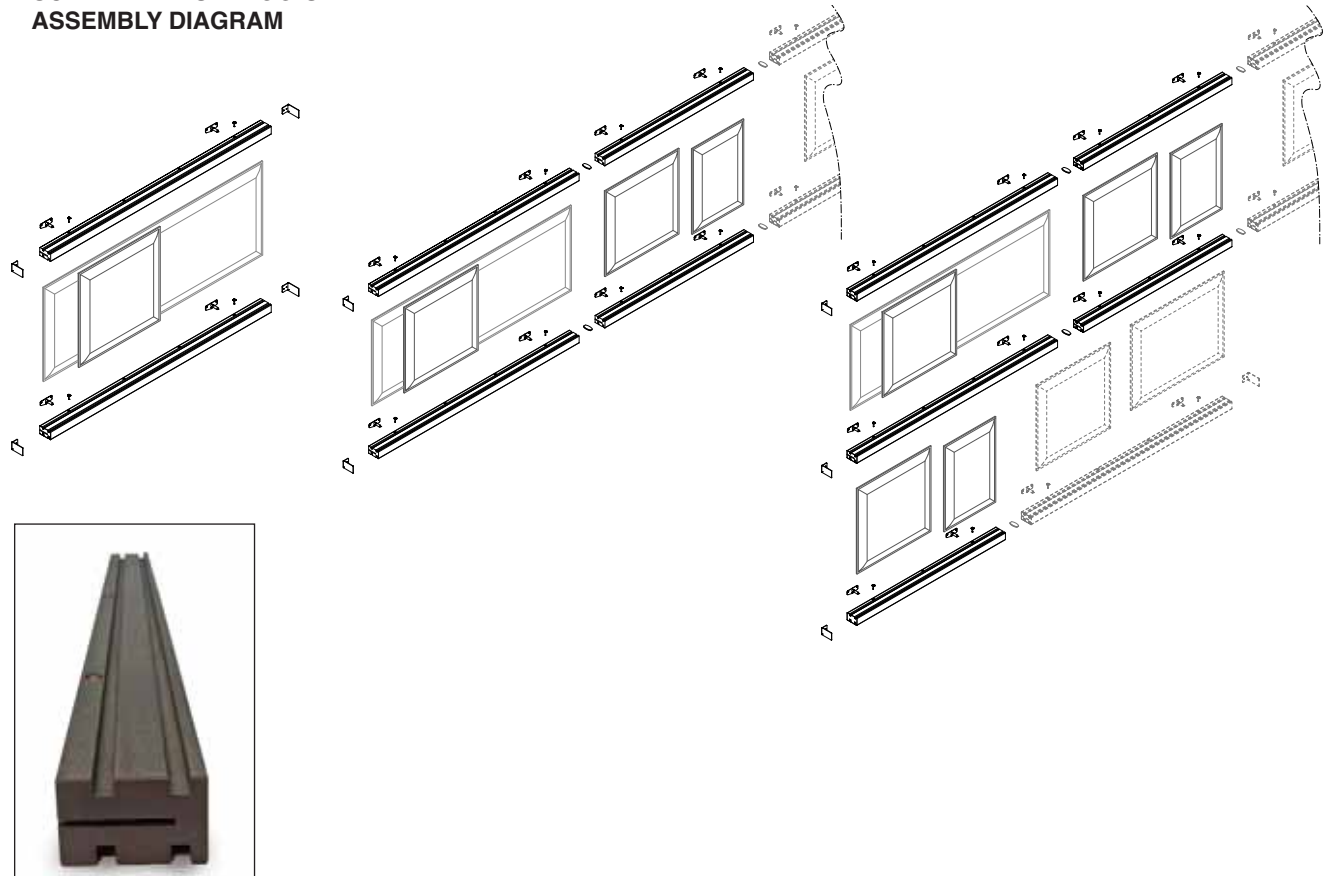



# PRESIDENT WOOD

design Philippe Nigro  
Snowsound® technology by Caimi Brevetti

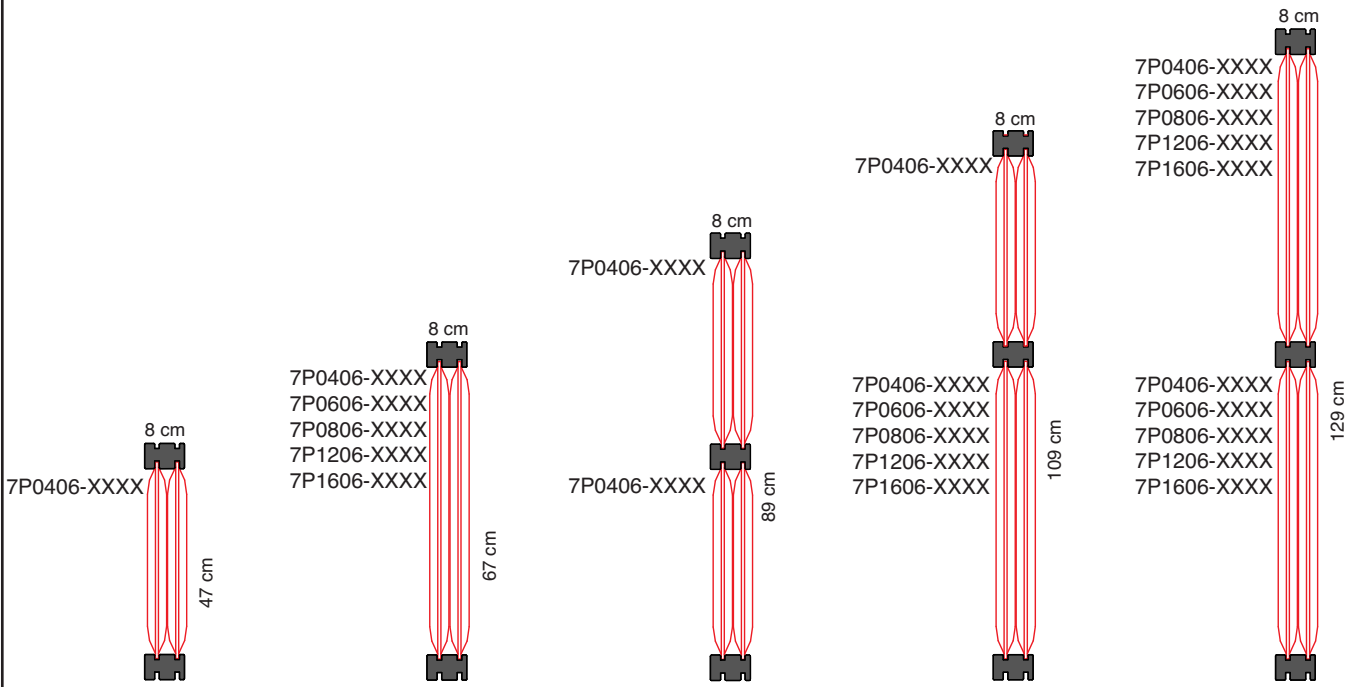

XXXX = Variante colore / XXXX = colour option / XXXX = option couleur / XXXX = opcion color / XXXX = Farbvariante

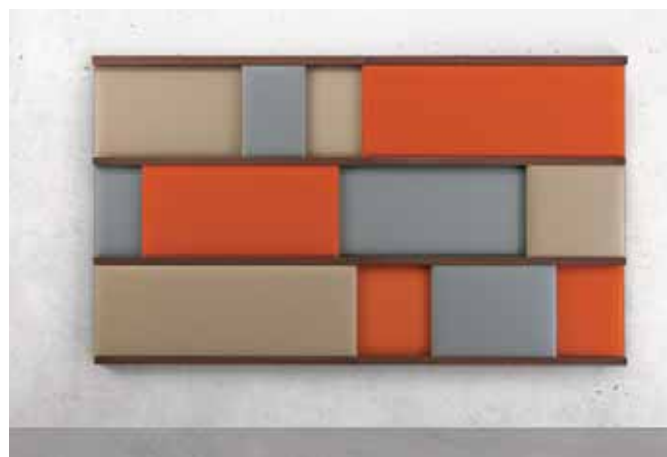
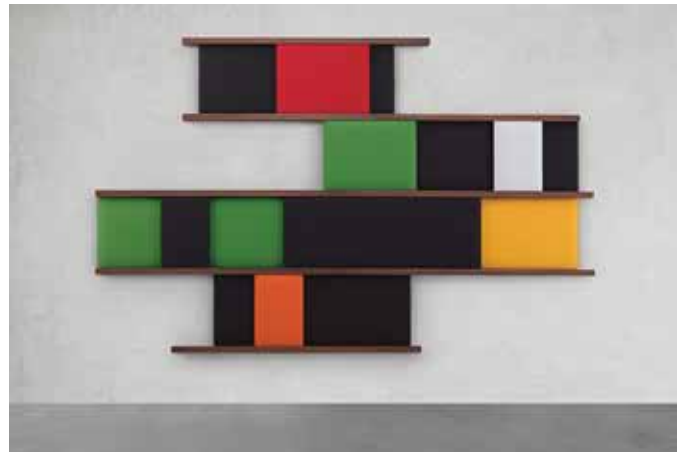
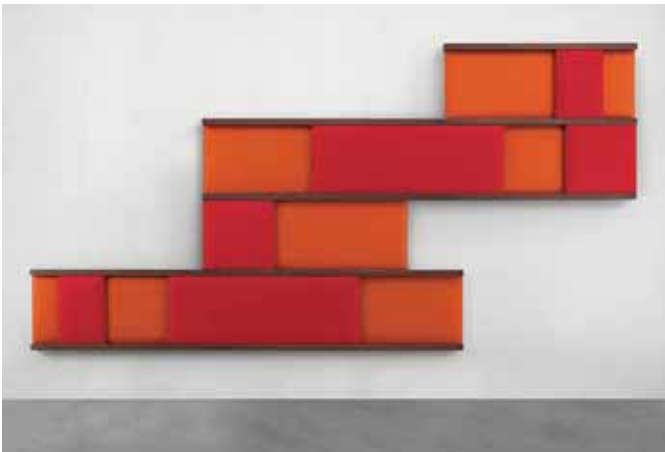

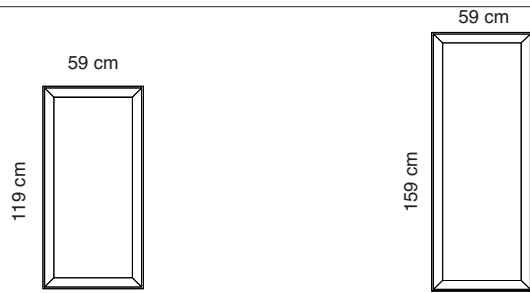

	Codice/Code Prezzo/Price	Codice/Code Prezzo/Price
<div style="background-color: #e0e0e0; padding: 5px; border: 1px solid black;">                     Bianco White Blanc <b>0001</b> </div>	<b>7B1206-0001</b>	<b>7B1606-0001</b>
<div style="background-color: #d3d3d3; padding: 5px; border: 1px solid black;">                     Grigio argento Silver grey Gris argenté <b>8004</b> </div>	<b>7B1206-8004</b>	<b>7B1606-8004</b>
<div style="background-color: #808080; padding: 5px; border: 1px solid black;">                     Grigio scuro Dark grey Gris foncté <b>8007</b> </div>	<b>7B1206-8007</b>	<b>7B1606-8007</b>
<div style="background-color: #d2b48c; padding: 5px; border: 1px solid black;">                     Beige Beige Beige <b>1008</b> </div>	<b>7B1206-1008</b>	<b>7B1606-1008</b>
<div style="background-color: #808080; padding: 5px; border: 1px solid black;">                     Tortora Dove-grey Taupe <b>2005</b> </div>	<b>7B1206-2005</b>	<b>7B1606-2005</b>
<div style="background-color: #ffd700; padding: 5px; border: 1px solid black;">                     Giallo Yellow Jaune <b>3008</b> </div>	<b>7B1206-3008</b>	<b>7B1606-3008</b>
<div style="background-color: #ffa500; padding: 5px; border: 1px solid black;">                     Arancione Orange Orange <b>4030</b> </div>	<b>7B1206-4030</b>	<b>7B1606-4030</b>
<div style="background-color: #dc143c; padding: 5px; border: 1px solid black;">                     Rosso Red Rouge <b>4027</b> </div>	<b>7B1206-4027</b>	<b>7B1606-4027</b>
<div style="background-color: #90ee90; padding: 5px; border: 1px solid black;">                     Verde chiaro Light green Vert clair <b>7004</b> </div>	<b>7B1206-7004</b>	<b>7B1606-7004</b>
<div style="background-color: #3cb371; padding: 5px; border: 1px solid black;">                     Verde Green Vert <b>7013</b> </div>	<b>7B1206-7013</b>	<b>7B1606-7013</b>
<div style="background-color: #4169e1; padding: 5px; border: 1px solid black;">                     Blu Blue Bleu <b>6071</b> </div>	<b>7B1206-6071</b>	<b>7B1606-6071</b>
<div style="background-color: #000000; padding: 5px; border: 1px solid black;">                     Nero Black Noir <b>8033</b> </div>	<b>7B1206-8033</b>	<b>7B1606-8033</b>

	Codice Code	Colore Colour	Prezzo Price	Descrizione Description
	7BC300-N			Coppia cinghie elastiche e piedini di appoggio a terra per pannelli PLI. Per 1 pannello cod. 7B1206-XXXX o 7B1606-XXXX.  Pair of elastic straps and small support feet for PLI panels. For product code 7B1206-XXXX-XXXX or 7B1606 (one panel).  Paire de sangles élastiques et verins pour appui au sol pour panneaux PLI. Pour 1 panneau réf. 7B1206-XXXX ou 7B1606-XXXX
	7BC300-GR			Set de 2 cintas elásticas con un pequeño soporte de pie para paneles PLI. Para 1 panel cod. 7B1206-XXXX o 7B1606-XXXX.
	7BC300-BE			Ein Paar elastische Gurte und kleine Standfüße für PLI Paneele. Für Art. Nr. 7B1206-XXXX-XXXX oder 7B1606 (ein Paneel)

	7BB320-C	Cromato Chrome-plated Chromé Cromado Verchromt	<p>Cavalletto in acciaio cromato per composizioni PLI. Obbligatorio per composizioni in linea o non autoportanti.</p> <p>Chrome-plated steel stand for PLI. Always required for in-line or not self-supporting compositions.</p> <p>Chevalet en acier chromé pour compositions PLI. Obligatoire pour compositions en ligne ou non-autoportantes.</p> <p>Base en acero cromado para composiciones PLI. Siempre para ser colocado en línea o en composiciones que no se soporten por sí solas.</p> <p>Verchromter Standfuß für PLI. Immer erforderlich für linear aufgestellte bzw. anderweitig nicht hinreichend stabile Zusammenstellungen.</p>

## Descrizione

### Description

Pannello con imbottitura interna in poliestere a **densità variabile** Snowsound® Technology. Rivestimento esterno in tessuto di poliestere Trevira CS®.

Panel with polyester internal padding with **variable density** Snowsound® Technology. Polyester covering in Trevira CS® fabric.

Panneau avec rembourrage interne en polyester à **densité variable** Snowsound® Technology. Revêtement externe en tissu de polyester Trevira CS®.

Panel con acolchado interior de poliéster de **densidad variable** Snowsound® Technology. Revestimiento exterior en tejido de poliéster Trevira CS®.

Paneel mit Polyester-Füllmaterial von **unterschiedlicher Dichte** Snowsound® Technology. Polyester-Bezug aus Trevira CS®-Material.



# BAFFLE

design Marc Sadler  
Snowsound® technology by Caimi Brevetti

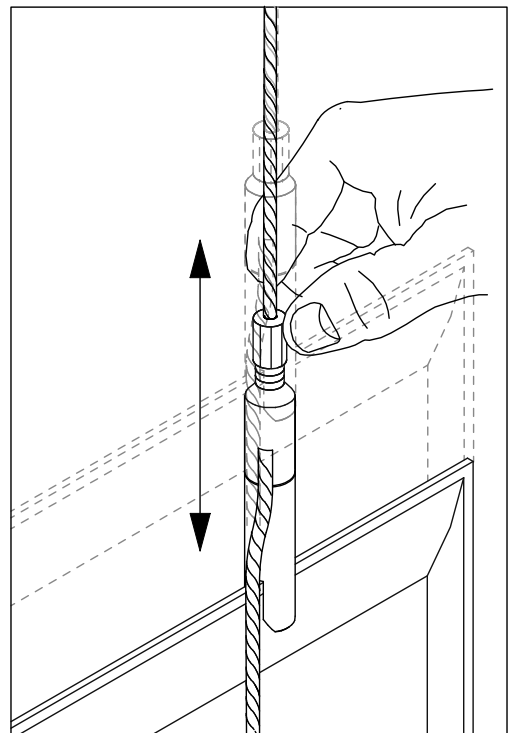

Altezza regolabile  
Adjustable height

Pannello con imbottitura interna in poliester a **densità variabile** Snowsound® Technology. Rivestimento esterno in tessuto di poliester Trevira CS®. Completi di kit per fissaggio a soffitto dei pannelli composto da: 2 attacchi a soffitto filettati M6 - 2 cavi in acciaio - 2 attacchi per pannello.  
Il pannello può essere fissato agli attacchi sia verticalmente che orizzontalmente. Gli attacchi si fissano lungo il pannello.

Panel with polyester internal padding with **variable density** Snowsound® Technology. Polyester covering in Trevira CS® fabric. Equipped with kit for the ceiling fixing for panels composed of: 2 ceiling hanging threaded M6, 2 steel cables, 2 hangings for panel.  
The panel can be clamped at both vertically and horizontally. The brackets are positioned along the panel.

Panneau avec rembourrage interne en polyester à **densité variable** Snowsound® Technology. Revêtement externe en tissu de polyester Trevira CS®. Fourni avec kit d'accrochage au plafond des panneaux composé de: 2 accrochages au plafond filetés M6 – 2 câbles en acier – 2 accrochages pour panneau.  
Le panneau peut se fixer aux joints en vertical ou horizontal. Les joints se fixent le long du panneau.

Panel con acolchado interior de poliéster de **densidad variable** Snowsound® Technology. Revestimiento exterior en tejido de poliéster Trevira CS®. Completo de kit para el montaje al techo por paneles compuesto por: 2 enganches al techo roscados M6 – 2 cables de acero - 2 enganches para panel.  
El panel puede ser enganchado tanto en vertical como en horizontal. Los soportes se posicionan a lo largo del panel.

Paneel mit Polyester-Füllmaterial von **unterschiedlicher Dichte** Snowsound® Technology. Polyester-Bezug aus Trevira CS®-Material. Ausgestattet mit Set für die Deckenbefestigung für Paneel bestehend aus: 2 Deckenbefestigungen für Gewinde M6, 2 Stahlseile, 2 Befestigungen für Paneel.  
Das Paneel kann sowohl vertikal als auch horizontal befestigt werden. Die Halterungen werden entlang des Paneels montiert.

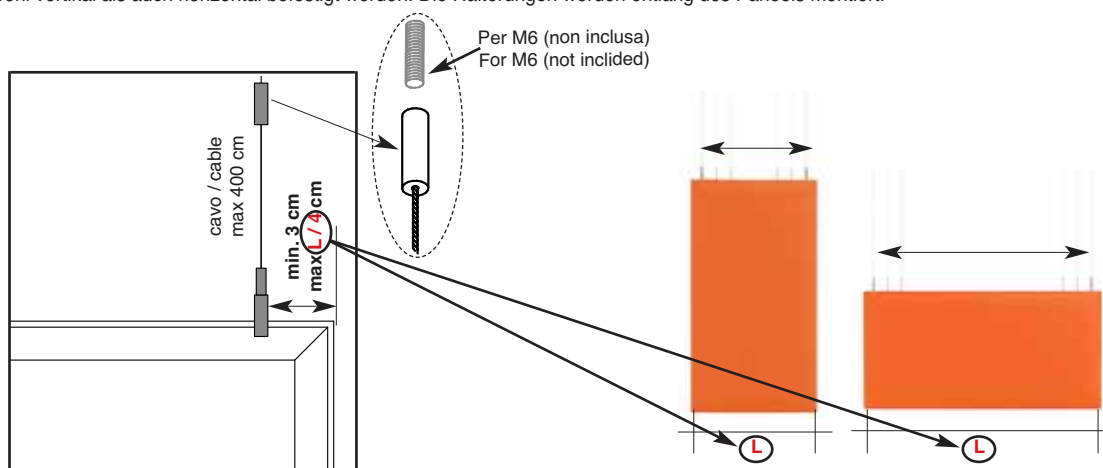

Pannello con imbottitura interna in poliester a **densità variabile** Snowsound® Technology. Rivestimento esterno in tessuto di poliester Trevira CS®. Completi di kit per fissaggio a soffitto dei pannelli composto da: 2 piastre a soffitto a 2 fori - 2 cavi in acciaio - 2 attacchi per pannello.  
Il pannello può essere fissato agli attacchi sia verticalmente che orizzontalmente. Gli attacchi si fissano lungo il pannello.

Panel with polyester internal padding with **variable density** Snowsound® Technology. Polyester covering in Trevira CS® fabric. Equipped with kit for the ceiling fixing for panels composed of: 2 ceiling plates with 2 holes - 2 steel cables - 2 hangings for panel.  
The panel can be clamped at both vertically and horizontally. The brackets are positioned along the panel.

Panneau avec rembourrage interne en polyester à **densité variable** Snowsound® Technology. Revêtement externe en tissu de polyester Trevira CS®. Fourni avec kit d'accrochage au plafond des panneaux composé de: 2 plaques pour plafond à 2 trous – 2 câbles en acier – 2 accrochages pour panneau.  
Le panneau peut se fixer aux joints en vertical ou horizontal. Les joints se fixent le long du panneau.

Panel con acolchado interior de poliéster de **densidad variable** Snowsound® Technology. Revestimiento exterior en tejido de poliéster Trevira CS®. Completo de kit para el montaje al techo por paneles compuesto por: 2 placas de techo con 2 huecos – 2 cables de acero - 2 enganches para panel.  
El panel puede ser enganchado tanto en vertical como en horizontal. Los soportes se posicionan a lo largo del panel.

Paneel mit Polyester-Füllmaterial von **unterschiedlicher Dichte** Snowsound® Technology. Polyester-Bezug aus Trevira CS®-Material. Ausgestattet mit Set für die Deckenbefestigung für Paneel bestehend aus: 2 Deckenmontageplatten mit 2 Befestigungsbohrungen - 2 Stahlseile - 2 Befestigungen für Paneel.  
Das Paneel kann sowohl vertikal als auch horizontal befestigt werden. Die Halterungen werden entlang des Paneels montiert.

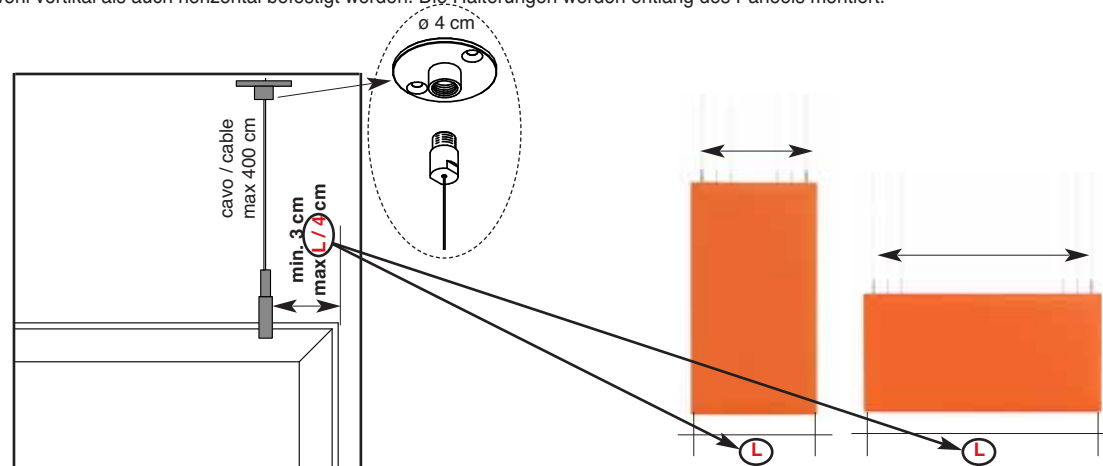

# BAFFLE

design Marc Sadler  
Snowsound® technology by Caimi Brevetti

Per M6 (non inclusa)  
For M6 (not included)

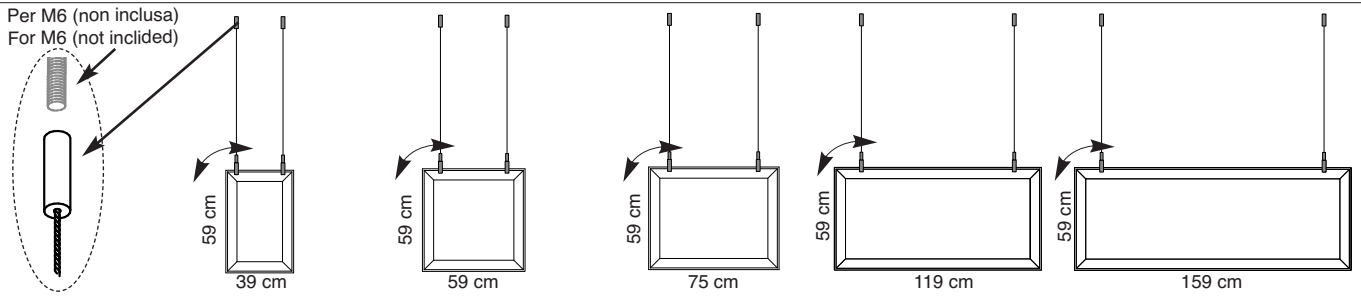

	Codice/Code Prezzo/Price	Codice/Code Prezzo/Price	Codice/Code Prezzo/Price	Codice/Code Prezzo/Price	Codice/Code Prezzo/Price
 Bianco White Blanc <b>0001</b>	<b>7BM0406-0001</b>	<b>7BM0606-0001</b>	<b>7BM0806-0001</b>	<b>7BM1206-0001</b>	<b>7BM1606-0001</b>
 Grigio argento Silver grey Gris argenté <b>8004</b>	<b>7BM0406-8004</b>	<b>7BM0606-8004</b>	<b>7BM0806-8004</b>	<b>7BM1206-8004</b>	<b>7BM1606-8004</b>
 Grigio scuro Dark grey Gris foncé <b>8007</b>	<b>7BM0406-8007</b>	<b>7BM0606-8007</b>	<b>7BM0806-8007</b>	<b>7BM1206-8007</b>	<b>7BM1606-8007</b>
 Beige Beige Beige <b>1008</b>	<b>7BM0406-1008</b>	<b>7BM0606-1008</b>	<b>7BM0806-1008</b>	<b>7BM1206-1008</b>	<b>7BM1606-1008</b>
 Tortora Dove-grey Taupe <b>2005</b>	<b>7BM0406-2005</b>	<b>7BM0606-2005</b>	<b>7BM0806-2005</b>	<b>7BM1206-2005</b>	<b>7BM1606-2005</b>
 Giallo Yellow Jaune <b>3008</b>	<b>7BM0406-3008</b>	<b>7BM0606-3008</b>	<b>7BM0806-3008</b>	<b>7BM1206-3008</b>	<b>7BM1606-3008</b>
 Arancione Orange Orange <b>4030</b>	<b>7BM0406-4030</b>	<b>7BM0606-4030</b>	<b>7BM0806-4030</b>	<b>7BM1206-4030</b>	<b>7BM1606-4030</b>
 Rosso Red Rouge <b>4027</b>	<b>7BM0406-4027</b>	<b>7BM0606-4027</b>	<b>7BM0806-4027</b>	<b>7BM1206-4027</b>	<b>7BM1606-4027</b>
 Verde chiaro Light green Vert clair <b>7004</b>	<b>7BM0406-7004</b>	<b>7BM0606-7004</b>	<b>7BM0806-7004</b>	<b>7BM1206-7004</b>	<b>7BM1606-7004</b>
 Verde Green Vert <b>7013</b>	<b>7BM0406-7013</b>	<b>7BM0606-7013</b>	<b>7BM0806-7013</b>	<b>7BM1206-7013</b>	<b>7BM1606-7013</b>
 Blu Blue Bleu <b>6071</b>	<b>7BM0406-6071</b>	<b>7BM0606-6071</b>	<b>7BM0806-6071</b>	<b>7BM1206-6071</b>	<b>7BM1606-6071</b>
 Nero Black Noir <b>8033</b>	<b>7BM0406-8033</b>	<b>7BM0606-8033</b>	<b>7BM0806-8033</b>	<b>7BM1206-8033</b>	<b>7BM1606-8033</b>



# BAFFLE

design Marc Sadler  
Snowsound® technology by Caimi Brevetti

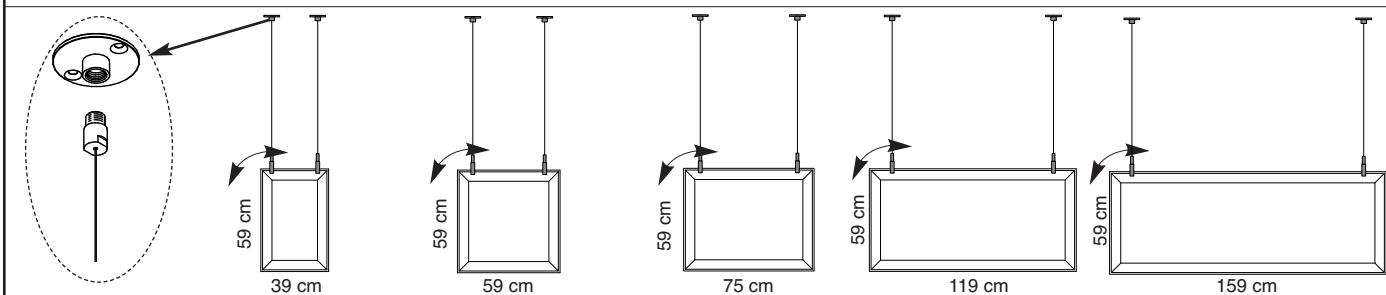

	Codice/Code Prezzo/Price	Codice/Code Prezzo/Price	Codice/Code Prezzo/Price	Codice/Code Prezzo/Price	Codice/Code Prezzo/Price
<div style="background-color: #e0e0e0; padding: 5px;">                     Bianco White Blanc <b>0001</b> </div>	7BF0406-0001	7BF0606-0001	7BF0806-0001	7BF1206-0001	7BF1606-0001
<div style="background-color: #d3d3d3; padding: 5px;">                     Grigio argento Silver grey Gris argenté <b>8004</b> </div>	7BF0406-8004	7BF0606-8004	7BF0806-8004	7BF1206-8004	7BF1606-8004
<div style="background-color: #808080; padding: 5px;">                     Grigio scuro Dark grey Gris foncé <b>8007</b> </div>	7BF0406-8007	7BF0606-8007	7BF0806-8007	7BF1206-8007	7BF1606-8007
<div style="background-color: #d2b48c; padding: 5px;">                     Beige Beige Beige <b>1008</b> </div>	7BF0406-1008	7BF0606-1008	7BF0806-1008	7BF1206-1008	7BF1606-1008
<div style="background-color: #808080; padding: 5px;">                     Tortora Dove-grey Taupe <b>2005</b> </div>	7BF0406-2005	7BF0606-2005	7BF0806-2005	7BF1206-2005	7BF1606-2005
<div style="background-color: #ffd700; padding: 5px;">                     Giallo Yellow Jaune <b>3008</b> </div>	7BF0406-3008	7BF0606-3008	7BF0806-3008	7BF1206-3008	7BF1606-3008
<div style="background-color: #ffa500; padding: 5px;">                     Arancione Orange Orange <b>4030</b> </div>	7BF0406-4030	7BF0606-4030	7BF0806-4030	7BF1206-4030	7BF1606-4030
<div style="background-color: #dc143c; padding: 5px;">                     Rosso Red Rouge <b>4027</b> </div>	7BF0406-4027	7BF0606-4027	7BF0806-4027	7BF1206-4027	7BF1606-4027
<div style="background-color: #90ee90; padding: 5px;">                     Verde chiaro Light green Vert clair <b>7004</b> </div>	7BF0406-7004	7BF0606-7004	7BF0806-7004	7BF1206-7004	7BF1606-7004
<div style="background-color: #3cb371; padding: 5px;">                     Verde Green Vert <b>7013</b> </div>	7BF0406-7013	7BF0606-7013	7BF0806-7013	7BF1206-7013	7BF1606-7013
<div style="background-color: #4169e1; padding: 5px;">                     Blu Blue Bleu <b>6071</b> </div>	7BF0406-6071	7BF0606-6071	7BF0806-6071	7BF1206-6071	7BF1606-6071
<div style="background-color: #000000; padding: 5px;">                     Nero Black Noir <b>8033</b> </div>	7BF0406-8033	7BF0606-8033	7BF0806-8033	7BF1206-8033	7BF1606-8033

TRA è un prodotto strutturale che richiede accorgimenti specifici per il montaggio. Il nostro ufficio tecnico è a disposizione per qualsiasi informazione.

TRA is a structural product that requires specific mounting devices. Our Technical Department is available for any information.

TRA est un produit structural pour lequel il faut de l'habileté spécifique pour le montage. Notre bureau d'étude est à votre disposition pour tout renseignement.

TRA es un producto estructural que necesita ser instalado en condiciones especiales. Nuestro Dep. tecnico está disponible para cualquier información al respecto.

TRA ist ein strukturelles Produkt, das spezielle Befestigungsvorrichtungen erfordert. Unsere technische Abteilung steht für alle notwendigen Informationen zur Verfügung.

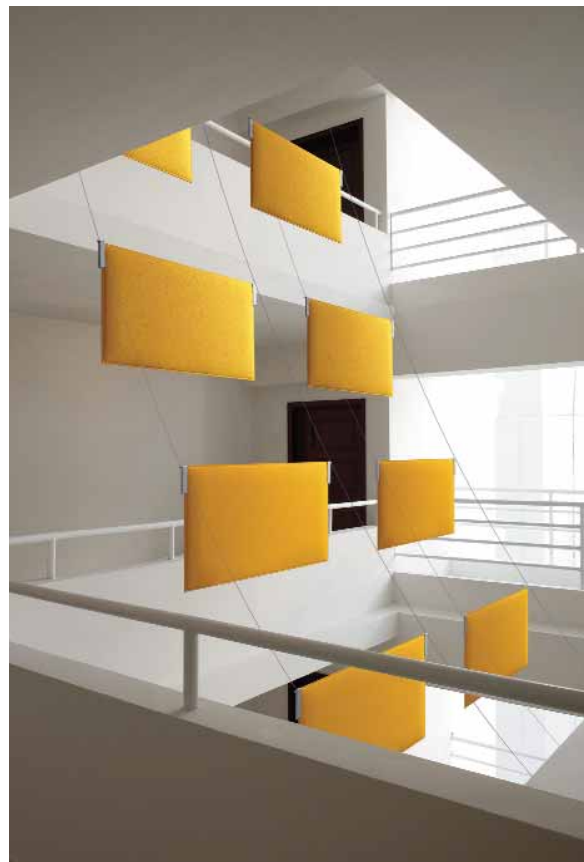
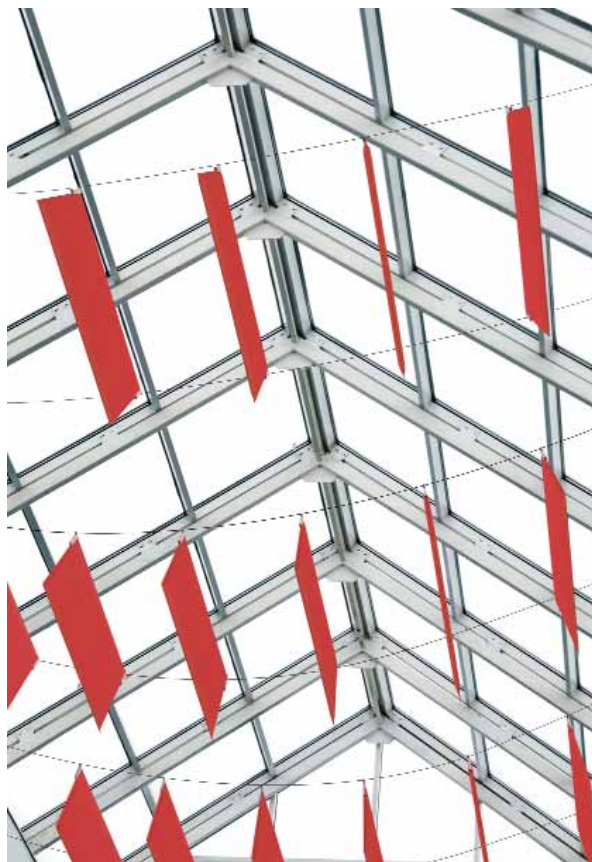

## Descrizione

### Description

Pannello con imbottitura interna in poliester a **densità variabile** Snowsound® Technology. Rivestimento esterno in tessuto di poliester Trevira CS®. Completo di attacchi snodati realizzati in acciaio e zama verniciata con polveri epossidiche colore grigio argento, per fissaggio pannello su cavi in acciaio inox ø 5 mm.

Panel with polyester internal padding with Snowsound® Technology **variable density**. Polyester covering in Trevira CS® fabric. Complete with articulated fixings made of silver epoxy painted steel and zamak, for fastening panels on stainless steel cables ø 5 mm.

Panneau avec rembourrage interne en polyester à **densité variable** Snowsound® Technology. Revêtement externe en tissu de polyester Trevira CS®. Avec joints articulés en acier et zamak peint en époxy coloris gris argent, pour fixation du panneau sur cables en acier inox ø 5 mm.

Panel con acolchado interior de poliéster de **densidad variable** Snowsound® Technology. Revestimiento exterior en tejido de poliéster Trevira CS®. Se completa con unas fijaciones articuladas fabricadas en acero pintado epoxi y zamak, para la fijación de los paneles a los cables en acero inoxidable de 5 mm.

Paneel mit Polyester-Füllmaterial von **unterschiedlicher Dichte** Snowsound® Technology. Polyester-Bezug aus Trevira CS®-Material. Inklusive beweglichen Halterungen aus silbern pulverbeschichtetem Stahl und Zamak-Legierung, zur Befestigung der Paneele an Edelstahlseilen mit ø 5 mm.

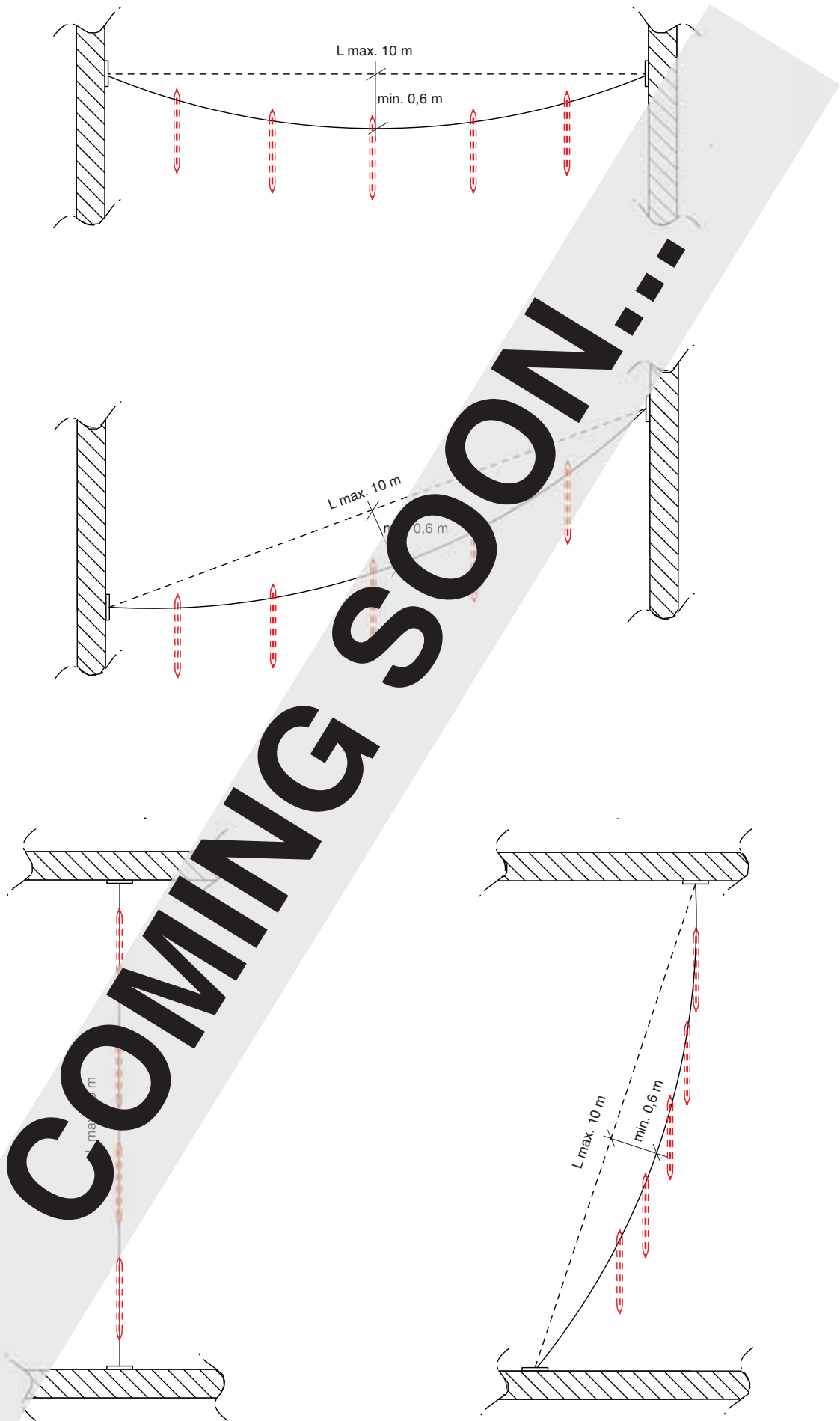

# TRA

design Marc Sadler  
Snowsound® technology by Caimi Brevetti

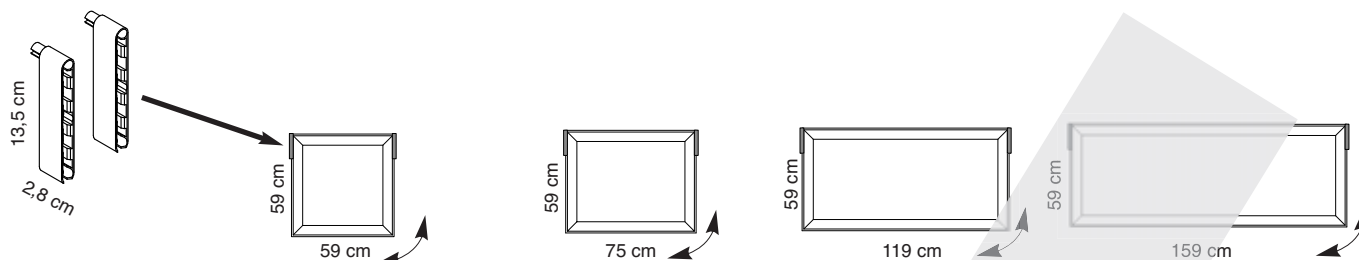

	Codice/Code Prezzo/Price	Codice/Code Prezzo/Price	Codice/Code Prezzo/Price	Codice/Code Prezzo/Price
 Bianco White Blanc <b>0001</b>	7BT0606-0001	7BT0806-0001	7BT1206-0001	7BT1606-0001
 Grigio argento Silver grey Gris argenté <b>8004</b>	7BT0606-8004	7BT0806-8004	7BT1206-8004	7BT1606-8004
 Grigio scuro Dark grey Gris foncé <b>8007</b>	7BT0606-8007	7BT0806-8007	7BT1206-8007	7BT1606-8007
 Beige Beige Beige <b>1008</b>	7BT0606-1008	7BT0806-1008	7BT1206-1008	7BT1606-1008
 Tortora Dove-grey Taupe <b>2005</b>	7BT0606-2005	7BT0806-2005	7BT1206-2005	7BT1606-2005
 Giallo Yellow Jaune <b>3008</b>	7BT0606-3008	7BT0806-3008	7BT1206-3008	7BT1606-3008
 Arancione Orange Orange <b>4030</b>	7BT0606-4030	7BT0806-4030	7BT1206-4030	7BT1606-4030
 Rosso Red Rouge <b>4027</b>	7BT0606-4027	7BT0806-4027	7BT1206-4027	7BT1606-4027
 Verde chiaro Light green Vert clair <b>7004</b>	7BT0606-7004	7BT0806-7004	7BT1206-7004	7BT1606-7004
 Verde Green Vert <b>7013</b>	7BT0606-7013	7BT0806-7013	7BT1206-7013	7BT1606-7013
 Blu Blue Bleu <b>6071</b>	7BT0606-6071	7BT0806-6071	7BT1206-6071	7BT1606-6071
 Nero Black Noir <b>8033</b>	7BT0606-8033	7BT0806-8033	7BT1206-8033	7BT1606-8033

COMING SOON!!!

Codice Code	Colore Colour	Prezzo Price	Descrizione Description
7B200	Inox		<p>Coppia cavi in acciaio inox per campata max L. 10 m</p> <p>Pair of stainless steel cables, to reach a maximum span of 10 m</p> <p>Paire de cables en acier inox pour travée max. L. 10 m</p> <p>Set de 2 cables en acero inoxidable , alcanza un máximo de 10 m</p> <p>Ein Paar Edelstahlseile, für eine maximale Reichweite von 10 m</p>

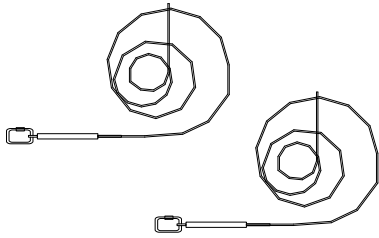

COMING SOON!!!

7B204

Grigio argento  
Silver grey  
Gris argenté  
Gris plata  
Silbergrau

Kit 4 piastre in acciaio zincato verniciato con polveri epossidiche per fissaggio cavi 7B200 a muro.

Set of four epoxy painted galvanized steel plates for cables' 7B200 wall-fixing.

Jeu de 4 platines en acier zingué peint en époxi pour fixation des cables 7B200 au mur.

Set de 4 pletinas en acero epoxi galvanizado para fijación a la pared de los cables 7B200.

Set von vier Montageplatten aus pulverbeschichtetem, verzinktem Stahl für die Wandbefestigung der Edelstahlseile 7B200.

ø 20 cm

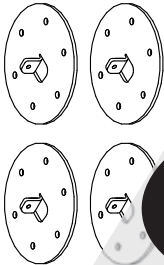

N. 6 fori ø 11 mm  
No. 6 holes ø 11 mm

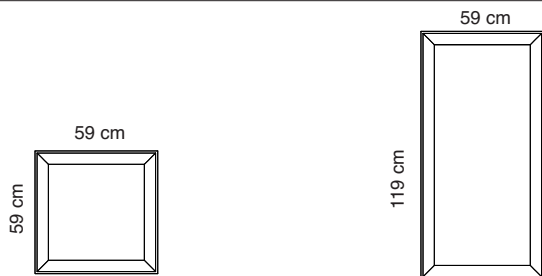

	Codice/Code Prezzo/Price	Codice/Code Prezzo/Price
Bianco White Blanc <b>0001</b>	<b>710606-0001</b> cad each	<b>711206-0001</b> cad each
Grigio argento Silver grey Gris argenté <b>8004</b>	<b>710606-8004</b> cad each	<b>711206-8004</b> cad each
Grigio scuro Dark grey Gris foncé <b>8007</b>	<b>710606-8007</b> cad each	<b>711206-8007</b> cad each
Beige Beige Beige <b>1008</b>	<b>710606-1008</b> cad each	<b>711206-1008</b> cad each
Tortora Dove-grey Taupe <b>2005</b>	<b>710606-2005</b> cad each	<b>711206-2005</b> cad each
Giallo Yellow Jaune <b>3008</b>	<b>710606-3008</b> cad each	<b>711206-3008</b> cad each
Arancione Orange Orange <b>4030</b>	<b>710606-4030</b> cad each	<b>711206-4030</b> cad each
Rosso Red Rouge <b>4027</b>	<b>710606-4027</b> cad each	<b>711206-4027</b> cad each
Verde chiaro Light green Vert clair <b>7004</b>	<b>710606-7004</b> cad each	<b>711206-7004</b> cad each



	Codice/Code Prezzo/Price	Codice/Code Prezzo/Price
Verde Green Vert 7013	710606-7013 cad each	711206-7013 cad each
Blu Blue Bleu 6071	710606-6071 cad each	711206-6071 cad each
Nero Black Noir 8033	710606-8033 cad each	711206-8033 cad each

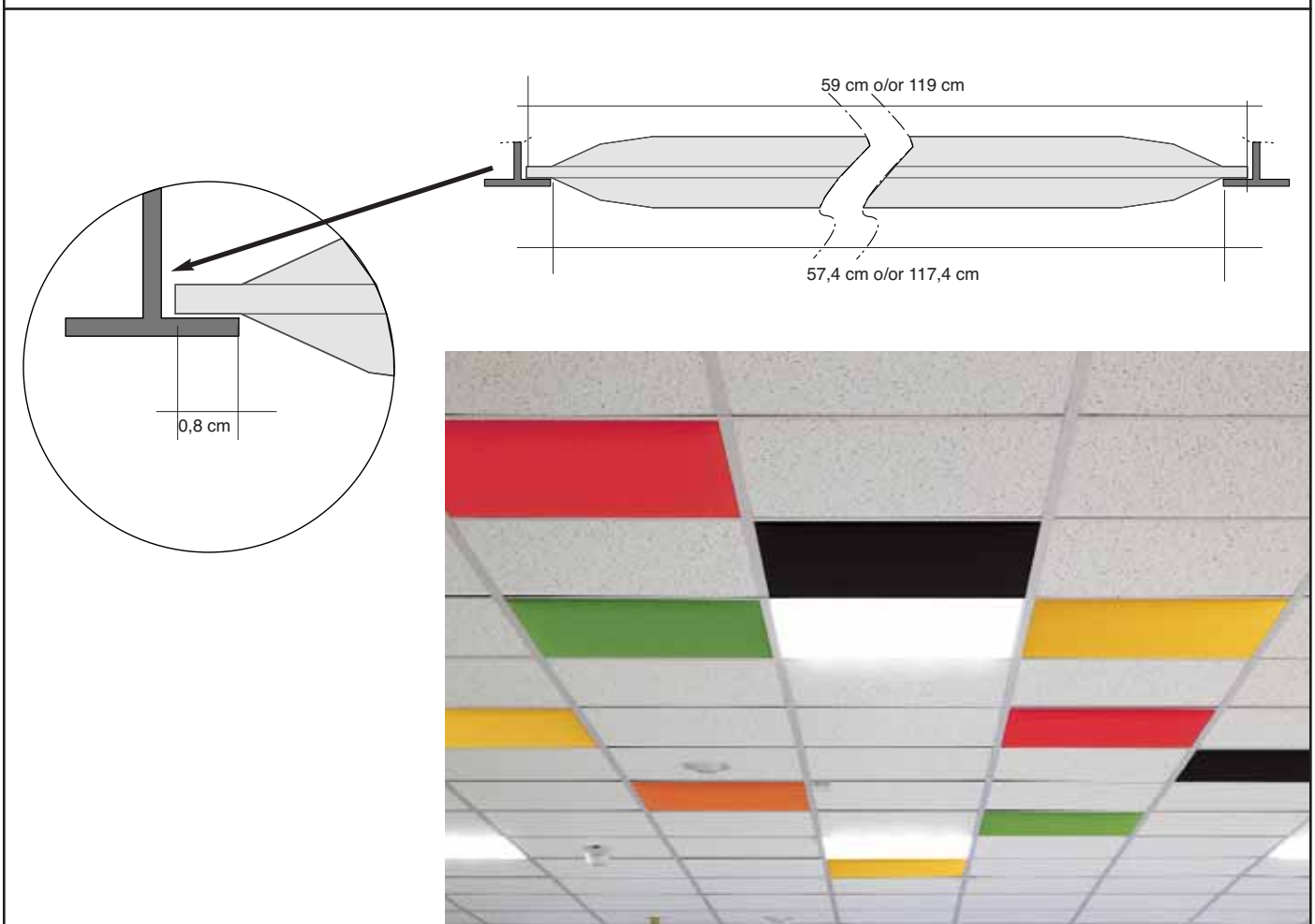

#### Descrizione Description



Pannello con imbottitura interna in poliester a **densità variabile** Snowsound® Technology. Rivestimento esterno in tessuto di poliester Trevira CS®.



Panel with polyester internal padding with Snowsound® Technology **variable density**. Polyester covering in Trevira CS® fabric.

Panneau avec rembourrage interne en polyester à **densité variable** Snowsound® Technology. Revêtement externe en tissu de polyester Trevira CS®.

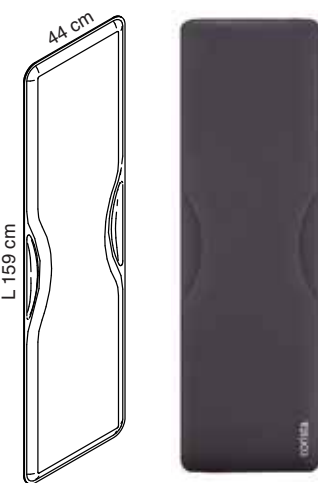
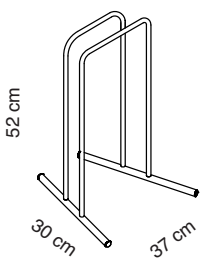
Panel con acolchado interior de poliéster de **densidad variable** Snowsound® Technology. Revestimiento exterior en tejido de poliéster Trevira CS®.

Panel mit Polyester-Füllmaterial von **unterschiedlicher Dichte** Snowsound® Technology. Polyester-Bezug aus Trevira CS®-Material.

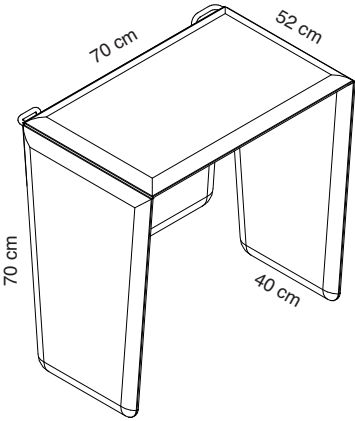
	Codice Code	Colore Colour	Prezzo Price	Descrizione Description
	<b>7C164-8033</b>	Nero Black Noir Negro Schwarz		<p>Pannello con imbottitura interna in poliester a <b>densità variabile</b> Snowsound® Technology e rivestimento esterno in tessuto di poliester Trevira CS®. Peso del singolo pannello 2,5 Kg.</p> <p>Panel with polyester internal padding with Snowsound® Technology <b>variable density</b> and polyester covering in Trevira CS® fabric. Weight of the single panel: 2,5 kg</p> <p>Panneau avec rembourrage interne en polyester à <b>densité variable</b> Snowsound® Technology et revêtement externe en tissu de polyester Trevira CS®. Poids d'un panneau: 2,5 kg</p> <p>Panel con acolchado interior de poliéster de <b>densidad variable</b> Snowsound® Technology y revestimiento exterior de tejido de poliéster Trevira CS®. Peso para singolo panel 2,5 Kg.</p> <p>Paneel mit Polyester-Füllmaterial von <b>unterschiedlicher Dichte</b> Snowsound® Technology und Polyester-Bezug aus Trevira CS®-Material. Gewicht eines Paneels: 2,5 kg.</p>
	<b>7C510/1-N</b>	Nero Black Noir Negro Schwarz		<p>Cavalletto in acciaio verniciato con polveri epossidiche per 1 pannello Corista o Mitesco.</p> <p>Epoxy powder-coated steel stand for one Corista or Mitesco panel.</p> <p>Chevalet en acier peint époxy pour 1 panneau Corista ou Mitesco.</p> <p>Soporte de acero recubierto epoxi para 1 panel Corista o Mitesco.</p> <p>Standfuß aus pulverbeschichtetem Stahl für ein Corista oder Mitesco Paneel</p>
	<b>7C164-BORSA</b>			<p>Borsa per pannelli Corista e Mitesco. Può contenere fino a 4 pannelli lunghezza 159 cm.</p> <p>Carry bag for Corista and Mitesco panels. Contains up to four panels 159 cm long.</p> <p>Sac pour panneaux Corista et Mitesco. Il peut contenir un maximum de 4 panneaux L.159 cm.</p> <p>Bolsa para paneles Corista o Mitesco. Puede contener hasta 4 paneles L.159 cm.</p> <p>Tragtasche für Corista und Mitesco Paneele, für bis zu 4 Paneele mit 159 cm Länge</p>



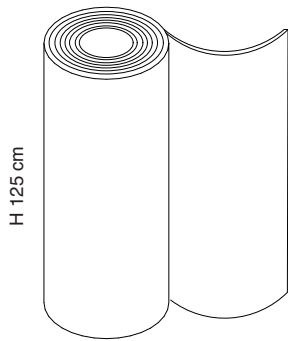

	Codice Code	Colore Colour	Prezzo Price	Descrizione Description
		 <p>Rosso Red Rouge Rojo Rot</p>		<p>Phone booth con struttura in tondino di acciaio verniciato e copertura composta da imbottitura interna in poliester e rivestimento esterno in tessuto di poliester Trevira CS®, completamente sfoderabile.</p> <p>Phone booth with powder-coated steel rod structure, cover composed by polyester internal padding and polyester Trevira CS® fabric external coating, totally removable.</p>
	<b>7CK700-4027</b>			
		 <p>Grigio argento Silver grey Gris argenté Gris plata Silbergrau</p>		<p>Cabine avec structure en tiges d'acier peint epoxy et couverture avec rembourrage interne en polyester et revêtement externe en tissu de polyester Trevira CS entièrement amovible.</p> <p>Phone Booth con estructura de hilo de acero recubierto y cobertura compuesta para acolchado interior en poliester y revestimiento exterior de tejido de poliester Trevira CS, totalmente amovible.</p> <p>Telefonzelle mit Gestell aus beschichtetem Stahlrohr zur Wandmontage, Abdeckung bestehend aus einer Polyester-Polsterung und einem komplett abziehbaren Bezug aus Polyesterstoff Trevira CS®</p>
	<b>7CK700-8004</b>			



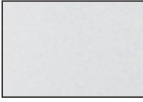

L. 600 cm

**1 Rotolo = 7,5 m<sup>2</sup>**

Codice Code	Colore Colour	Prezzo Price	Descrizione Description
 <b>7SW6-0001</b>	Bianco White Blanc Weiss Blanco		Rotolo di feltro in Poliestere rivestito in tessuto di poliestere Trevira CS®.  Roll of polyester felt coated with Trevira CS® polyester fabric.  Rouleau de feutre en Polyester recouvert en tissu de polyester Trevira CS®.  Rollo de fieltro de poliéster tapizado con tejido de poliéster Trevira Cs®.  Rolle von Polyester-Filz, bezogen mit Trevira CS® Polyesterstoff.
 <b>7SW6-8004</b>	Grigio argento Silver grey Gris argenté Gris plata Silbergrau		
 <b>7SW6-1008</b>	Beige Beige Beige Beige Beige		
 <b>7SW6-7013</b>	Verde Green Vert Verde Grüner		
 <b>7SW6-4027</b>	Rosso Red Rouge Rojo Rot		



# CONDIZIONI GENERALI DI VENDITA

1. Il presente listino annulla e sostituisce i precedenti e non costituisce offerta.
2. I prezzi dei prodotti possono essere variati dalla venditrice in qualsiasi momento senza preavviso; tutti i prezzi non sono comprensivi di montaggio.
3. La venditrice si riserva la facoltà di modificare, a proprio insindacabile giudizio e senza preavviso alcuno, i materiali costruttivi, le caratteristiche tecniche ed estetiche, nonché le dimensioni dei prodotti.
4. Le immagini dei prodotti contenute nel catalogo fotografico sono puramente indicative.
5. La vendita è regolata, oltre che dalle condizioni particolari volta a volta pattuite, dalle presenti condizioni generali, che si reputano conosciute dall'acquirente; eventuali clausole derogatorie a quanto previsto nelle presenti condizioni generali di vendita devono risultare per iscritto.
6. Le proposte d'acquisto e/o gli ordini dell'acquirente sono condizionati all'accettazione espressa o all'inizio dell'esecuzione del contratto da parte della venditrice, nei casi in cui ciò sia consentito. Qualsiasi successiva modifica al contratto di vendita non sarà valida e vincolante ove non risulti da atto scritto e sottoscritto dalla parte nei cui confronti tale modifica viene invocata.
7. Conformemente all'articolo 1510 codice civile, la consegna dei beni venduti si ha con la rimessione degli stessi al vettore o allo spedizioniere, sicché i beni stessi viaggiano a rischio e pericolo dell'acquirente; ciò vale anche nei casi in cui la merce venga venduta franco arrivo all'indirizzo dell'acquirente. Ogni eventuale richiesta, reclamo e/o azione relativi alla spedizione o al trasporto della merce dovrà essere promossa dall'acquirente direttamente nei confronti dello spedizioniere o del vettore. Ogni eventuale danno, perdita o avaria dei beni venduti dipendente dalla spedizione o dal trasporto dei medesimi non esonera l'acquirente dal pagamento del prezzo convenuto.
8. Il termine di consegna è indicativo e non tassativo; lo stesso potrà essere ritardato senza alcun obbligo di indennizzo o risarcimento di eventuali danni diretti o indiretti subiti dall'acquirente per la ritardata consegna e senza che ciò possa comunque comportare la risoluzione del contratto di vendita per inadempimento della venditrice.
9. Fatti salvi i casi di forza maggiore, in caso di scioperi ed in tutti gli altri casi che impediscano temporaneamente alla venditrice di regolarmente adempiere al contratto di vendita, è fatto salvo il diritto della medesima venditrice di recedere dal contratto, senza che l'acquirente sia legittimato ad eventuali pretese di danno, fatta salva nell'ipotesi di recesso la restituzione di quanto eventualmente versato a titolo di acconto.
10. Il pagamento del prezzo di vendita dei prodotti dovrà avvenire presso la sede della venditrice. In caso di pagamento ritardato, l'acquirente sarà automaticamente costituito in mora e sarà tenuto al pagamento degli interessi nella misura e con la decorrenza stabilita dal D.Lgs. 231/2002 per i ritardi di pagamento nelle transazioni commerciali.
11. La venditrice non risponde degli eventuali vizi dei prodotti conosciuti o conoscibili da parte dell'acquirente, che non abbia immediatamente respinto la merce. Le contestazioni od i reclami sulle quantità dei prodotti devono essere segnalate all'atto della consegna, con annotazione sul relativo documento di trasporto. La eventuale sostituzione del prodotto non significa accettazione della contestazione o del reclamo. L'accredito all'acquirente verrà fatto solo dopo la restituzione dei prodotti difettosi ed a condizione che sia stata riconosciuta o altrimenti accertata la responsabilità dalla venditrice.
12. I disegni, i modelli, i grafici e le altre informazioni tecniche dei prodotti oggetto di vendita, così come i campioni, i cataloghi, le fotografie e materiali simili, rimangono sempre di proprietà intellettuale della venditrice e non possono pertanto essere copiati, né trasmessi ad altri, né utilizzati in altro modo.
13. Le somme versate a titolo di caparra confirmatoria potranno essere ritenute dalla venditrice in caso di revoca dell'ordine e/o in ogni altro caso di inadempimento dell'acquirente che giustifichi il recesso della venditrice, salvo il diritto di chiedere l'adempimento del contratto e salvo altresì il diritto di chiedere il risarcimento del maggiore danno. Per converso, nel caso di adempimento da parte dell'acquirente dei propri obblighi contrattuali, le somme da questi versate a titolo di caparra confirmatoria saranno imputate al pagamento del prezzo; le stesse, così come gli eventuali acconti, saranno comunque infruttifere di interessi.
14. L'eventuale tolleranza di una delle parti di comportamenti dell'altra posti in essere in violazione delle clausole che regolano la vendita non costituisce rinuncia ai diritti derivanti dalle clausole violate né al diritto di esigere l'esatto adempimento di tutti i termini e condizioni previsti dal contratto di vendita.
15. La venditrice mantiene la proprietà dei prodotti consegnati fino al completo pagamento del prezzo indicato in fattura. Fino a tale data i prodotti consegnati sono considerati solo come depositati presso l'acquirente. Quest'ultimo si accolla quindi il rischio di danni che i prodotti depositati possano subire imputabili a qualsiasi causa.
16. L'acquirente è invitato a prestare particolare attenzione sul fatto che non tutti i prodotti riportati nel presente listino sono compatibili con il mercato statunitense o con quello canadese. Conseguentemente, qualora l'acquirente intendesse utilizzare o esportare detti prodotti negli Stati Uniti d'America e/o, in ogni caso, in qualsiasi altro paese extra UE, è obbligato a preventivamente contattare l'ufficio commerciale della venditrice per avere la conferma che il prodotto interessato risponda a tutti i requisiti tecnici ed agli standard legali previsti a tutela dei consumatori finali del mercato di destino. La venditrice declina ogni responsabilità conseguente alle iniziative assunte dall'acquirente senza essere stata preventivamente informata ed indipendentemente dall'eventuale autorizzazione scritta della venditrice all'esportazione e/o all'uso del prodotto in un paese extra UE.
17. L'acquirente è tenuto ad informare i propri clienti e/o gli utilizzatori finali sulle caratteristiche del prodotto al fine di ridurre al minimo il rischio di un uso improprio che potrebbe esporre la venditrice a possibili ragioni di danno. In difetto di tale attività informativa preventiva, l'acquirente esonera espressamente la venditrice da qualsiasi ipotetica responsabilità.
18. Tutte le controversie che dovessero insorgere in relazione alla vendita, suoi atti modificativi ed esecutivi, comprese quelle inerenti alla validità, efficacia, interpretazione, esecuzione e risoluzione del contratto, saranno devolute alla competenza esclusiva del Foro di Milano.
19. In ogni caso, prima di procedere all'acquisto dei prodotti è necessario consultare le condizioni di vendita, le caratteristiche tecniche e le seguenti:

## AVVERTENZE

- prima di procedere all'installazione dei prodotti è necessario verificare la portanza della parete/pavimento/superficie su cui verranno collocati assicurandosi che siano idonei al tipo di utenza e/o di utilizzo a cui sono destinati;
- i prodotti non sono idonei all'uso da parte di bambini;
- i prodotti non sono idonei ad essere utilizzati in ambienti esterni;
- i prodotti applicati a parete/pavimento/superficie prevedono l'installazione con dispositivi di ancoraggio che non compaiono nelle illustrazioni del catalogo;
- i prodotti devono essere montati e/o installati esclusivamente da personale tecnico competente utilizzando strumenti ed attrezzi adatti allo scopo;
- prima di procedere al montaggio ed all'installazione dei prodotti è necessario leggere attentamente le istruzioni allegiate ai prodotti, prestando particolare attenzione sia alle avvertenze che ai disegni esplicativi; qualora le istruzioni non fossero allegiate contattare l'ufficio tecnico della venditrice;
- per fissare i prodotti a parete/pavimento/superfici, è necessario utilizzare dei dispositivi di fissaggio adeguati ed in grado di resistere alle forze generate; in ogni caso è necessario utilizzare degli elementi di sostegno idonei a reggere ogni singola struttura;
- in caso di installazione non corretta e/o in caso di superamento dei carichi massimi indicati nel presente listino e/o nelle istruzioni allegiate ai singoli prodotti, si potrebbe creare una situazione di pericolo, i prodotti potrebbero cedere, cadere e causare danni a cose e/o persone: non superare i carichi evidenziati;
- in caso di dubbi sulle modalità di installazione e/o sulla portanza della parete/pavimento/superficie su cui verrà collocato il prodotto non procedere alla installazione;
- attenersi alle istruzioni e alle composizioni riportate nel presente listino; per composizioni differenti e/o per ulteriori informazioni sui prodotti o sulle modalità di installazione degli stessi contattare l'ufficio tecnico della venditrice.
- Il testo facente fede è esclusivamente quello in lingua italiana, le traduzioni hanno la finalità esclusiva di semplificarne la lettura.

# GENERAL TERMS OF SALE

1. This price list cancels and replaces the previous ones and is not a proposal.
2. The product prices may be changed by the vendor at any moment without prior notice; all prices are not inclusive of installation.
3. The vendor reserves the right to alter the construction materials, the technical and visual characteristics and also the dimensions of the products, at its own unquestionable discretion and without any prior notice.
4. The images of the products contained in the photographic catalogue are purely indicative.
5. In addition to the specific terms agreed each time, sale is governed by these general terms, which are considered to be known by the purchaser; any clauses derogating from these general terms of sale must be in writing.
6. The purchaser's purchase proposals and/or orders are conditional upon the vendor expressly accepting or starting fulfilment of the agreement, in cases where this is permitted. Any subsequent amendment to the sales agreement will not be valid and binding unless entered in a written document signed by the party being asked to accept this amendment.
7. In compliance with article 1510 of the Italian Civil Code, delivery of the goods sold is with remittance thereon to the carrier or forwarder, so that the goods travel at the purchaser's risk and danger; this also applies in cases where the goods are sold free to the purchaser's address. Any other request, complaint and/or action relating to shipment or transport of the goods must be brought by the purchaser directly against the forwarder or the carrier. Any damage, loss or breakage of the goods sold which is attributable to shipment or transport thereof will not exempt the purchaser from liability for payment of the agreed price.
8. The delivery time is indicative and not binding; it may be delayed without any obligation of indemnity or compensation of any direct or consequential damages suffered by the purchaser as a result of late delivery and without this leading to termination of the sales agreement due to the vendor's non-fulfilment.
9. With the exception of cases of force majeure, in the case of strikes and all other cases which temporarily prevent the vendor from fulfilling the sales agreement properly, the vendor is entitled to withdraw from the agreement, without the purchaser being entitled to claim any damages, except for the repayment in the case of withdrawal, of any amount paid as an advance.
10. Payment of the sale price of the products must be made at the vendor's registered office. In the case of late payment, the purchaser will automatically be placed in arrears and will be required to pay interest in the amount and from the time required by Legislative Decree 231/2002 for late payment in commercial transactions.
11. The vendor is not liable for any defects of the products known or knowable to the purchaser, who has not immediately refused to accept delivery of the goods. Disputes or complaints over the product quantities must be notified upon delivery, with noting on the relative transport document. Replacement of the product does not signify acceptance of the claim or complaint. The purchaser will only be credited the amount after the faulty products have been returned and provided that the vendor's liability has been recognised or otherwise ascertained.
12. The drawings, models, graphs and other technical information on the products being sold, and also samples, catalogues, photographs and similar materials, always remain the intellectual property of the vendor and may not be copied, or transmitted to others, or used in any other way.
13. The amounts paid by way of a deposit may be withheld by the vendor if the order is cancelled and/or in all other cases of non-fulfilment by the purchaser which justifies the vendor's withdrawal, without prejudice to the right to request fulfilment of the agreement and also the right to demand compensation of greater damages. In contrast, if the purchaser fulfils its contractual obligations, the amounts paid by way of deposit will be allocated to payment of the price; said amounts, and all other advances, will be non-interest-bearing.
14. Any tolerance by one of the parties of the other's conduct which breaches the clauses governing sale does not constitute waiving of the rights deriving from the breached clauses nor the right to demand precise fulfilment of all the terms and conditions contained in the sales agreement.
15. The vendor maintains ownership of the products until complete payment of the price indicated on the invoice. Up until that date, the products delivered are considered as only held in deposit by the purchaser. The latter therefore accepts the risk of damages to the products deposited attributable to any cause.
16. The purchaser is invited to pay particular attention to the fact that not all products on the price list are compatible with the US or Canadian markets. Consequently, if intending to use or export said products into the USA and/or, in any case, into any other non-EU country, the purchaser is required to contact the vendor's sales office beforehand for confirmation that the product concerned satisfies all technical requirements and legal standards protecting final consumers on the market of destination. The vendor declines all liability consequent upon initiatives taken by the purchaser without it having been informed beforehand and irrespective of any written authorisation of the vendor for exportation to and/or use of the product in a non-EU country.
17. The purchaser is required to inform its own customers and/or final users of the product characteristics, in order to reduce to a minimum the risk of improper use which could expose the vendor to possible claims of damage. In the case of failure to provide this prior information, the purchaser expressly exempts the vendor from any hypothetical liability.
18. Milan Court will be the sole court of competent jurisdiction for all disputes which may arise in relation to sale and any actions of amendment and enforcement thereof, including those relating to the validity, effectiveness, interpretation, fulfilment and termination of the agreement.
19. In any case, before purchasing the products, it is necessary to consult the terms of sale, technical characteristics and the following:

## WARNINGS

- Before installing the products, check the bearing capacity of the wall/floor/surface on which they will be positioned, ensuring they are suitable for the intended type of user/use.
- The products are not suitable for use by children.
- The products are not suitable for use outside.
- If the products are applied to the wall/floor/surface, they must be installed with anchoring devices (not shown in the catalogue).
- The products must be assembled and/or installed exclusively by skilled technical personnel, using instruments and tools appropriate for this purpose.
- Carefully read the instructions enclosed with the product before proceeding with assembly and installation, paying particular attention to the warnings and to the explanatory drawings; if the instructions are not attached, contact the vendor's technical office.
- Suitable attachment devices must be used to attach the products to the wall/floor/surfaces, which are strong enough to resist the forces generated; in any case, suitable supporting elements to support each individual element must be used.
- In the case of incorrect installation and/or the maximum loads indicated on this price list and/or the instructions attached to the individual products being exceeded, a situation of danger could be created, the products could collapse, fall and cause damage to people and/or things: do not exceed the loads indicated.
- Do not install the product in the case of any doubts over the methods of installation and/or bearing capacity of the wall/floor/surface on which the product is to be positioned.
- Comply with the instructions and compositions shown on this price list; for different compositions and/or further information on the products or installation methods, contact the vendor's technical office.
- The authentic text is only in Italian, the translation has the mere purpose of simplifying the reading.



# CONDITIONS GÉNÉRALES DE VENTE

1. Le présent catalogue des prix annule et remplace les précédents et ne constitue pas une offre.
2. Les prix des produits peuvent être changés par la venderesse à tout moment sans préavis; aucun prix ne comprend le montage.
3. La venderesse se réserve le droit de modifier, selon sa décision sans appel et sans aucun préavis, les matériaux servant à la construction, les caractéristiques techniques et esthétiques ainsi que les dimensions des produits.
4. Les photos des produits contenues dans le catalogue photographique sont fournies à seul titre indicatif.
5. La vente est réglementée, en plus des conditions particulières convenues à chaque fois, par les présentes conditions générales, qui sont considérées comme connues par l'acheteur; d'éventuelles clauses dérogatoires aux dispositions des présentes conditions générales de vente doivent être mises par écrit.
6. Les offres d'achat et/ou commandes de l'acheteur sont soumises à l'acceptation explicite ou au début de l'exécution du contrat par la venderesse, dans les cas où cela est possible. Aucune modification suivante au contrat de vente ne sera valide et contraignante sans acte écrit et signé par la partie contre laquelle cette modification est invoquée.
7. Conformément à l'article 1510 du code civil, la livraison des biens vendus se fait par la remise de ceux-ci au transporteur ou à l'expéditionnaire, de sorte que les dits biens voyagent aux risques et périls de l'acheteur; cette règle vaut aussi dans les cas où la marchandise est vendue franco adresse de l'acheteur. Toute éventuelle demande, réclamation et/ou action relative à l'expédition ou au transport de la marchandise devra être faite par l'acheteur directement à l'expéditionnaire ou au transporteur. Les éventuels dommages, perte ou avarie des biens vendus dépendant de leur expédition ou du transport n'exonèrent pas l'acheteur du paiement du prix convenu.
8. La date de livraison est indicative et non péremptoire; elle pourra être retardée sans aucune obligation d'indemnisation ou de dédommagement d'éventuels dommages directs ou indirects subis par l'acheteur à cause de la livraison retardée et sans que cela puisse de toute manière comporter la résiliation du contrat de vente pour inexécution de la venderesse.
9. Sauf les cas de force majeure, en cas de grèves et dans tous les autres cas qui empêchent temporairement la venderesse de remplir normalement le contrat de vente, la venderesse a le droit de résilier le contrat, sans pour autant que ce fait légitime l'acheteur à d'éventuelles prétentions de dommage, sauf, dans l'hypothèse de résiliation, la restitution des sommes éventuellement versées à titre d'acompte.
10. Le paiement du prix de vente des produits devra se faire au siège de la venderesse. En cas de paiement en retard, l'acheteur sera automatiquement mis en demeure et sera tenu de payer des intérêts au taux et dans les délais établis par le décret de loi 231/2002 régissant les retards de paiement dans les transactions commerciales.
11. La venderesse n'est pas responsable des éventuels vices des produits connus ou que l'acheteur aurait pu connaître s'il n'a pas immédiatement refusé la marchandise. Les contestations ou les réclamations sur les quantités des produits doivent être signalées au moment de la livraison, au moyen d'une note écrite sur le document de transport. L'éventuel remplacement du produit ne signifie pas l'acceptation de la contestation ou de la réclamation. Le remboursement de l'acheteur sera fait uniquement après la restitution des produits défectueux et à condition qu'ait été reconnue ou autrement établie la responsabilité de la venderesse.
12. Les dessins, les modèles, les graphiques et les autres informations techniques sur les produits objet de la vente, ainsi que les échantillons, les catalogues, les photos et tout le matériel similaire demeurent toujours la propriété intellectuelle de la venderesse et ne peuvent par conséquent pas être copiés, ni transmis à des tiers, ni utilisés d'aucune autre manière.
13. Les sommes versées à titre d'arrhes de confirmation pourront être retenues par la venderesse en cas de révocation de la commande et/ou dans tout autre cas d'inexécution de l'acheteur justifiant la résiliation par la venderesse, sauf le droit de demander l'exécution du contrat et aussi sauf le droit de demander le dédommagement du dommage supérieur. Au contraire, dans le cas d'exécution par l'acheteur de ses propres obligations contractuelles, les sommes qu'il aura versées à titre d'arrhes de confirmation seront imputées au paiement du prix; celles-ci, ainsi que les éventuels acomptes, ne produiront pas d'intérêts.
14. L'éventuelle tolérance par une des parties des comportements de l'autre en violation des clauses qui régissent la vente ne constitue pas une renonciation aux droits découlant des clauses violées ni au droit d'exiger l'exécution exacte de tous les termes et conditions prévus par le contrat de vente.
15. La venderesse garde la propriété des produits livrés jusqu'au paiement total du prix indiqué dans la facture. Jusqu'à cette date, les produits livrés sont considérés comme seulement déposés chez l'acheteur. Ce dernier prend donc en charge le risque des dommages que les produits déposés pourraient subir qu'ils soient imputables à n'importe quelle cause.
16. L'acheteur est invité à faire particulièrement attention au fait que tous les produits indiqués dans le présent catalogue des prix ne sont pas nécessairement compatibles avec les marchés américain ou canadien. Par conséquent, si l'acheteur a l'intention d'utiliser ou d'exporter les dits produits aux États-Unis et, dans tous les cas, dans n'importe quel autre pays extra UE, il doit préalablement contacter le bureau commercial de la venderesse pour avoir la confirmation que le produit concerné remplit toutes les exigences techniques et est conforme aux standards légaux prévus pour la protection des consommateurs finaux du marché de destination. La venderesse décline toute responsabilité pour des initiatives prises par l'acheteur dont elle n'a pas été préalablement informée et indépendamment de l'éventuelle autorisation écrite de la venderesse pour l'exportation et ou l'emploi du produit dans un pays extra UE.
17. L'acheteur est tenu d'informer ses propres clients et/ou les utilisateurs finaux des caractéristiques du produit afin de réduire au minimum le risque d'emploi impropre qui pourrait exposer la venderesse à d'éventuelles demandes de dédommagement. À défaut de cette activité d'information préventive, l'acheteur exonère expressément la venderesse de toute hypothétique responsabilité.
18. Toutes les controverses qui devraient surgir relatives à la vente, à ses actes de modification et d'exécution, y compris celles concernant la validité, l'efficacité, l'interprétation, l'exécution et la résiliation du contrat, seront du ressort exclusif du Tribunal de Milan.
19. De toute manière, avant de procéder à l'achat des produits, il faut consulter les conditions de vente, les caractéristiques techniques et les suivantes:

## MISES EN GARDE

- avant de procéder à l'installation des produits, il faut vérifier la portée maximum des murs/ sol/surfaces sur lesquelles ils seront placés en s'assurant qu'ils soient adaptés au type d'usage et/ou d'utilisation auquel ils sont destinés;
- les produits ne doivent pas être utilisés par les enfants;
- les produits ne doivent pas être utilisés à l'extérieur des bâtiments;
- les produits appliqués aux murs/ sol/surfaces comportent l'installation avec des dispositifs d'ancrage qui ne sont pas montrés dans les illustrations du catalogue;
- les produits doivent être montés et/ou installés exclusivement par du personnel technique compétent en utilisant des instruments et outils prévus à cet effet;
- avant de procéder au montage et à l'installation des produits, il faut lire attentivement les instructions jointes aux produits, en faisant particulièrement attention tant aux instructions qu'aux dessins explicatifs; si les instructions ne sont pas jointes, contacter le bureau technique de la venderesse;
- pour fixer les produits aux murs/sol/surfaces, il faut utiliser des dispositifs de fixation adéquats et en mesure de résister aux forces générées; dans tous les cas il est nécessaire d'utiliser des éléments de soutien adéquats à supporter chaque structure en particulier;
- en cas d'installation non correcte et/ou en cas de dépassement des charges maximales indiquées dans le présent catalogue des prix et/ou dans les instructions jointes à chaque produit, une situation de danger pourrait se créer, les produits pourraient céder, tomber et causer des dommages aux choses et/ou aux personnes: ne pas dépasser les charges indiquées;
- en cas de doutes sur les modes d'installation et/ou sur le maximum de portée des murs/ sol/surface sur lesquels sera placé le produit, ne pas procéder à l'installation;
- s'en tenir aux instructions et aux compositions indiquées dans le présent catalogue des prix; pour des compositions différentes et/ou pour toute information supplémentaire sur les produits ou sur les modes d'installation de ceux-ci, contacter le bureau technique de la venderesse.
- Le text de référence est seulement celui en italien, les traductions ont le seul but de simplifier la lecture.

# CONDICIONES DE VENTA

1. Esta lista de precios anula y sustituye las anteriores y no es una oferta.
2. El vendedor puede cambiar los precios de los productos en cualquier momento sin previo aviso; ninguno de los precios incluye el montaje.
3. El vendedor se reserva el derecho de modificar, a su entera discreción y sin previo aviso, los materiales de construcción, las características técnicas y estéticas así como también las dimensiones de los productos.
4. Las imágenes de los productos que figuran en el catálogo fotográfico son meramente indicativas.
5. La venta se rige no sólo por las condiciones especiales acordadas caso por caso, sino también por las presentes condiciones generales, que el comprador ha de conocer; posibles cláusulas de exención a lo dispuesto en las presentes condiciones generales de venta deben figurar por escrito.
6. Las propuestas de compra y/o pedidos del comprador dependen de la aceptación o del inicio del contrato por parte del vendedor, en los casos en que esto esté permitido. Cualquier modificación posterior al contrato de venta no será válida ni vinculante si no figura en un contrato escrito, firmado por la parte en relación a la cual se pide dicha modificación.
7. En conformidad con el artículo 1510 del Código Civil, la entrega de los bienes vendidos se considera a partir de la remisión de los mismos al transportista o al agente de transporte, es decir que los bienes viajan a riesgo y peligro del comprador; esto vale también en los casos en los cuales la mercancía haya sido vendida con el transporte pagado hasta la sede del comprador. Cualquier posible petición, queja y/o acción relacionada con el envío o transporte de mercancías deberá ser efectuada por el comprador directamente contra el transportista o agente de transportes. Cualquier posible daño, pérdida o rotura de los bienes vendidos debidos a la expedición o al transporte de los mismos no exime al comprador de pagar el precio convenido.
8. El plazo de entrega es indicativo y no perentorio; el mismo podrá retrasarse sin ninguna obligación de indemnización ni compensación de los daños directos o indirectos sufridos por el comprador por la entrega tardía y sin que esto pueda llevar a la terminación del contrato de venta por incumplimiento del vendedor.
9. Excepto en los casos de fuerza mayor, en caso de huelgas y en los demás casos que impidan temporalmente al vendedor cumplir normalmente con el contrato de venta, el vendedor tendrá el derecho de rescindir el contrato, sin que el comprador pueda presentar ninguna reclamación por daños y perjuicios, salvo en el caso de cancelación, la devolución de lo pagado por adelantado.
10. El pago del precio de venta de los productos debe llevarse a cabo en las instalaciones del vendedor. En caso de demora en el pago, el comprador estará automáticamente en mora y deberá pagar intereses en la medida y con la fecha establecida por el Decreto Legislativo. 231/2002 de la morosidad en las transacciones comerciales.
11. El vendedor no se hace responsable por posibles defectos de los productos identificados o identificables por parte del comprador, que no haya rechazado inmediatamente. Cualquier disputa o queja sobre las cantidades de productos deben ser indicadas en el momento de la entrega, con la anotación en el documento de transporte correspondiente. La posible sustitución del producto no implica la aceptación de la objeción o queja. El pago al comprador se realizará sólo una vez efectuada la devolución de los productos defectuosos y siempre que se haya reconocido o comprobado la responsabilidad del vendedor.
12. Los dibujos, modelos, diagramas y otra información técnica de los productos vendidos, así como las muestras, catálogos, fotografías y otros materiales similares, siguen siendo de propiedad intelectual del vendedor y no pueden ser copiados ni transmitidos a otras personas ni utilizarse de otro modo.
13. Las sumas abonadas en concepto de señal confirmatoria podrán ser retenidas por el vendedor en caso de revocación del pedido y/o ante cualquier otro caso de incumplimiento por parte del comprador que justifique la retirada del vendedor, salvo el derecho a exigir el cumplimiento del contrato y también el derecho a reclamar indemnización por daños y perjuicios adicionales. Por el contrario, en el caso de cumplimiento por parte del comprador de sus obligaciones contractuales, las cantidades pagadas en concepto de señal confirmatoria serán consideradas con el pago del precio; las mismas, así como también los pagos iniciales, serán de todos modos sin intereses.
14. Cualquier tolerancia de una de las partes a conductas iniciadas en violación de las disposiciones que rigen la venta no constituirá una renuncia a derechos que se deriven de las disposiciones violadas o el derecho a exigir el estricto cumplimiento de todos los términos y condiciones establecidos en contrato de venta.
15. El vendedor conserva la propiedad de los bienes entregados hasta el pago total del precio indicado en la factura. Hasta esa fecha, los productos entregados han de considerarse sólo como bienes depositados en la sede del comprador. Por lo tanto, este último se asume el riesgo por los daños que los mismos puedan sufrir debidos a cualquier causa.
16. El comprador ha de prestar especial atención al hecho de que no todos los productos que figuran en este catálogo son compatibles con el mercado de los EE.UU. o de Canadá. Por lo tanto, si el comprador tiene la intención de utilizar o exportar dichos productos en los Estados Unidos de América y/o, de todos modos, en cualquier otro país fuera de la UE, debe antes y imperativamente ponerse en contacto con la oficina de ventas del vendedor para confirmar que el producto en cuestión cumpla con todos los requisitos técnicos y las normas establecidas en la legislación para proteger a los consumidores en el mercado de destino. El vendedor no se asume ninguna responsabilidad con respecto a las iniciativas adoptadas por el comprador, sin haber sido informado previamente e independientemente de la posible autorización por escrito por parte del vendedor a la exportación y/o uso del producto en un país fuera de la UE.
17. El comprador está obligado a informar a sus clientes y/o usuarios finales de las características del producto para reducir al mínimo el riesgo de mal uso que podría exponer al vendedor a posibles motivos de daño. En ausencia de dicha actividad de información preventiva, el comprador libera expresamente al vendedor de cualquier responsabilidad hipotética.
18. Todas las controversias que pudiesen surgir en relación con la venta, documentos modificativos y ejecutivos, incluidas las relativas a la validez, eficacia, interpretación, ejecución y terminación del contrato, serán resueltas exclusivamente por el Tribunal competente de Milán.
19. De todos modos, antes de comprar los productos es necesario leer las condiciones de venta, las especificaciones técnicas y las siguientes:

## ADVERTENCIAS

- antes de instalar los productos es necesario controlar las características de la pared/piso /superficie en donde se colocarán, asegurándose que sean adecuados al tipo de usuario y/o de uso final;
- los productos no son adecuados para ser utilizados por niños;
- los productos no son adecuados para ser utilizados al aire libre;
- los productos aplicados a la pared/piso/superficie prevén el uso de dispositivos de anclaje que no están ilustrados en el catálogo;
- los productos deben ser montados y/o instalados exclusivamente por personal técnico cualificado utilizando los instrumentos y las herramientas específicas para dicho fin;
- antes de montar y instalar los productos es necesario leer atentamente las instrucciones adjuntas a los productos, prestando especial atención tanto a las advertencias como a los diseños de explicación; si faltan las instrucciones, póngase en contacto con la oficina técnica del vendedor;
- para fijar los productos a la pared/piso/superficies es necesario utilizar los dispositivos de sujeción adecuados capaces de resistir a las fuerzas generadas; se debe de todas formas utilizar elementos de soporte capaces de sostener cada una de las estructuras;
- en caso de montaje incorrecto y/o en caso de un exceso de las cargas máximas especificadas en la presente lista y/o en las instrucciones adjuntas a cada producto, se podría crear una situación de peligro, los productos podrían ceder, caer y causar daños a cosas y/o personas; no exceder las cargas indicadas;
- en caso de dudas acerca de cómo efectuar la instalación y/o de las características de la pared /piso/superficie sobre el cual será montado el producto, no lleve a cabo la instalación;
- siga las instrucciones y elija las combinaciones que figuran en esta lista; para combinaciones diferentes y/o otras informaciones sobre los productos o sobre el modo de instalación de los mismos, póngase en contacto con la oficina técnica del vendedor.
- El texto auténtico es exclusivamente lo en idioma italiano, las traducciones tienen el único propósito de simplificar la lectura.

# ALLGEMEINE VERKAUFSBEDINGUNGEN

1. Die vorliegende Preisliste hebt alle vorausgegangenen Listen auf, ersetzt sie und stellt kein Angebot dar.
2. Die Preise der Produkte können vom Verkäufer jederzeit ohne entsprechende Benachrichtigung geändert werden; keiner der Preise enthält die Montagekosten.
3. Der Verkäufer behält sich das Recht vor, nach seinem eigenen, unanfechtbaren Urteil und ohne entsprechende Benachrichtigung, Materialbeschaffenheit, technische Eigenschaften und Aussehen sowie die jeweiligen Abmessungen der Produkte zu ändern.
4. Bei den im bebilderten Katalog enthaltenen Abbildungen der Produkte handelt es sich um reine Beispielfotos.
5. Abgesehen von fallweise ausgehandelten Sonderkonditionen wird der Verkauf von den vorliegenden allgemeinen Bedingungen geregelt, von denen vorausgesetzt wird, dass der Käufer sie kennt; eventuell von den in den vorliegenden allgemeinen Verkaufsbedingungen abweichende Klauseln bedürfen jeweils der schriftlichen Form.
6. Die Kaufanbote und/oder Aufträge des Käufers bedürfen zuvor der ausdrücklichen Annahme bzw. in Fällen, in denen dies gestattet ist, des Beginns der Vertragserfüllung seitens des Verkäufers. Jegliche nachträgliche Änderung des Kaufvertrages ist nicht gültig und bindend, sofern nicht entsprechende schriftliche und jeweils von der Partei, die diese Änderung annehmen soll, unterzeichnete Unterlagen vorliegen.
7. Gemäß Art. 1510 Italienisches Bürgerliches Gesetzbuch (Codice Civile) findet die Lieferung der verkauften Waren bei deren Abgabe an den Transportunternehmer bzw. den Spediteur statt, so dass die Waren auf Risiko und Gefahr des Empfängers reisen; dies gilt auch in den Fällen, in denen die Ware frei Haus verkauft wird. Jeglicher Anspruch, Reklamation und/oder Klage betreffend die Lieferung oder den Transport der Waren muss vom Kunden direkt an den Transportunternehmer oder Spediteur gerichtet werden. Jeder eventuelle Schaden, Verlust oder Defekt der verkauften Waren, der durch den Versand bzw. Transport verursacht wurde, befreit den Käufer nicht von der Pflicht, den vereinbarten Kaufpreis zu zahlen.
8. Der Liefertermin gilt als ungefähre Angabe und ist nicht bindend; er kann sich verzögern, ohne dass eine Ersatz- oder Entschädigungspflicht für eventuelle direkte oder indirekte, vom Käufer infolge der verspäteten Lieferung erlittenen Schäden besteht und ohne dass dies zur Auflösung des Kaufvertrags aufgrund von Nichterfüllung des Verkäufers berechtigt.
9. Mit Ausnahme von Fällen höherer Gewalt, bei Streiks oder in allen anderen Fällen, durch die der Verkäufer vorübergehend außerstande ist, den Kaufvertrag ordnungsgemäß zu erfüllen, hat der Verkäufer das Recht, vom Vertrag zurückzutreten, ohne dass der Käufer berechtigt ist, eventuelle Schadensersatzansprüche zu stellen, mit Ausnahme der Rückzahlung einer allfälligen Anzahlung im Falle eines Rücktritts.
10. Die Zahlung des Verkaufspreises der Produkte hat direkt an den Sitz des Verkäufers zu erfolgen. Bei verspäteter Zahlung befindet sich der Käufer automatisch in Verzug und ist verpflichtet, Zinsen in dem von der Gesetzesverordnung 231/2002 über Zahlungsverzögerungen bei Handelsgeschäften festgelegten Umfang sowie mit den entsprechenden Fristen zu zahlen.
11. Der Verkäufer haftet nicht für eventuelle dem Käufer bekannte oder erkennbare Mängel, wenn dieser die Ware nicht umgehend zurückgewiesen hat. Beanstandungen oder Reklamationen in Bezug auf Produktmengen müssen jeweils bei Auslieferung gemeldet und auf den entsprechenden Transportunterlagen vermerkt werden. Der eventuelle Ersatz des Produkts ist dabei nicht gleichbedeutend mit einer Akzeptanz der Beanstandung oder Reklamation. Die entsprechende Gutschrift für den Verkäufer erfolgt erst nach Rückgabe der mangelhaften Produkte und unter der Voraussetzung, dass die Verantwortung des Käufers anerkannt oder anderweitig festgestellt wurde.
12. Die Zeichnungen, Modelle, Darstellungen und anderen technischen Informationen über die Produkte, die den Gegenstand des Verkaufs bilden, ebenso wie die Muster, Kataloge, Photos und ähnlichen Materialien bleiben immer geistiges Eigentum des Verkäufers und dürfen daher weder kopiert, noch anderen überlassen oder in irgendeiner anderen Form genutzt werden.
13. Die als Anzahlung zur Bestätigung entrichteten Beträge können vom Verkäufer bei Annullierung des Auftrags und/oder in jedem anderen Fall einer Nichterfüllung seitens des Käufers einbehalten werden, die den Rücktritt des Verkäufers rechtfertigt, vorbehaltlich des Rechts, die Erfüllung des Vertrags zu verlangen und ebenso vorbehaltlich des Rechts, die Entschädigung eines darüber hinausgehenden Schadens zu verlangen. Umgekehrt werden im Fall der Erfüllung der Vertragsverpflichtungen seitens des Käufers die von diesem als Anzahlung zur Bestätigung entrichteten Beträge auf den Kaufpreis angerechnet; diese Beträge gelten auf jeden Fall, ebenso wie alle anderen Vorauszahlungen, als unverzinslich.
14. Die eventuelle Hinnahme einer der Parteien von Verhaltensweisen der anderen Vertragspartei, durch die die Verkaufsbedingungen verletzt werden, stellt keinen Verzicht auf sich aus verletzten Klauseln ergebende Rechte dar, noch auf das Recht, die korrekte Erfüllung aller Fristen und Bedingungen zu verlangen, die vom Kaufvertrag vorgesehen sind.
15. Der Verkäufer behält das Eigentumsrecht an den gelieferten Produkten bis zur vollständigen Zahlung des jeweils in der Rechnung angegebenen Preises. Bis zu diesem Datum gelten die gelieferten Produkte nur als beim Verkäufer hinterlegt. Dieser letztere übernimmt daher auch das Risiko für Schäden, die an den hinterlegten Produkten aus irgendeinem Grund entstehen könnten.
16. Der Käufer wird aufgefordert, besondere Aufmerksamkeit darauf zu verwenden, dass nicht alle in dieser Preisliste angegebenen Produkte mit dem amerikanischen oder kanadischen Markt vereinbar sind. Daher ist der Käufer, falls er vorhat die genannten Produkte in die USA und/oder in irgendein Nicht-EU-Land zu exportieren, verpflichtet, sich jeweils vorher an die Handelsabteilung des Verkäufers zu wenden, um die Bestätigung zu erhalten, dass das betreffende Produkt allen technischen Erfordernissen und den gesetzlichen Vorschriften entspricht, die zum Schutz des Endverbrauchers in dem jeweiligen Bestimmungsmarkt vorgesehen sind. Der Verkäufer übernimmt dabei keine Verantwortung für vom Käufer ergriffene Initiativen, wenn er nicht vorher darüber in Kenntnis worden ist und unabhängig von der eventuellen schriftlichen Genehmigung des Verkäufers zum Export und/oder zur Verwendung des Produkts in einem Nicht-EU-Land.
17. Der Käufer ist verpflichtet, seine Kunden und/oder Endverbraucher über die Eigenschaften des Produkts in Kenntnis zu setzen, um die Gefahr von deren missbräuchlicher Verwendung, die den Verkäufer möglichen Schadensansprüchen aussetzen könnte, auf ein Mindestmaß zu reduzieren. In Ermangelung dieser vorherigen Informationsstätigkeit befreit der Käufer den Verkäufer ausdrücklich von jeder möglichen Verantwortung.
18. Sämtliche Streitfragen, die sich im Zusammenhang mit dem Verkauf, sowie sämtlichen Änderungen, einschließlich derer in Bezug auf die Gültigkeit, Wirksamkeit, Auslegung, Durchführung und Auflösung des Vertrags ergeben können, unterliegen der ausschließlichen Zuständigkeit des Gerichtsstands von Mailand (Italien).
19. Auf jeden Fall müssen vor Kauf der Produkte jeweils die Verkaufsbedingungen, die technischen Eigenschaften sowie folgende

## HINWEISE

berücksichtigt werden:

- Vor der Installation der Produkte muss die Tragfähigkeit der Wand/des Bodens/der Fläche überprüft werden, an der/auf dem sie angebracht werden sollen, wobei kontrolliert werden muss, ob sie der Art der Benutzer/Verwendung entsprechen, für die sie vorgesehen sind.
- Die Produkte sind nicht für Kinder geeignet.
- Die Produkte sind nicht für die Verwendung im Außenbereich geeignet.
- Die an der Wand/am Boden/ der Fläche montierten Produkte sehen eine Installation mit Verankerungsvorrichtungen vor, die nicht in den Abbildungen des Katalogs gezeigt werden.
- Die Produkte dürfen ausschließlich durch technisches Fachpersonal montiert und/oder installiert werden, wobei jeweils entsprechend geeignete Geräte und Ausrüstung verwendet werden müssen.
- Vor der Montage und Installation der Produkte muss die den Produkten beiliegende Gebrauchsanweisung aufmerksam durchgelesen werden, wobei besonders die Hinweise und die entsprechenden erklärenden Zeichnungen beachtet werden müssen; sollte die Gebrauchsanweisung nicht beiliegen, wenden Sie sich bitte an die technische Abteilung des Verkäufers.
- Um die Produkte an Wand/Boden/Oberflächen zu befestigen, müssen geeignete Beschläge verwendet werden, die in der Lage sind, die auf diese Weise erzeugten Kräfte auszuhalten; auf jeden Fall müssen passende Halterungen verwendet werden, die jedes einzelne Element tragen können.
- Bei nicht vorschriftsmäßiger Installation und/oder im Fall der Überschreitung der in der vorliegenden Preisliste und/oder den jedem einzelnen Produkt beiliegenden Gebrauchsanweisungen angegebenen Höchstlasten könnten sich Gefahrensituationen ergeben, die Produkte könnten nachgeben, herunterfallen und Sach- und/oder Personenschäden verursachen: die angegebenen Lasten daher nicht überschreiten.
- Bei Zweifeln in Bezug auf die Art der Installation und/oder die jeweilige Tragfähigkeit der Wand/des Bodens/der Fläche, an der/auf dem das Produkt angebracht werden soll ist, nicht mit der Installation beginnen.
- Halten Sie sich an die in der vorliegenden Preisliste enthaltenen Anweisungen und Zusammenstellungen halten; bei anderweitigen Zusammenstellungen und/oder für nähere Informationen über die Produkte und die Art ihrer Installation wenden Sie sich bitte an die technische Abteilung des Verkäufers.
- Es ist ausschließlich der italienische Text verbindlich, die Übersetzungen dienen lediglich der vereinfachten Lesbarkeit.

[www.caimi.com](http://www.caimi.com)